



**PORT OF HOOD RIVER COMMISSION**  
**REGULAR MEETING AGENDA**  
**Tuesday, April 18, 2023, 5:00 p.m.**  
**Port of Hood River Conference Room**  
1000 E. Port Marina Drive, Hood River

---

1. **Call to Order** – 5:00 p.m.
    - a. Modifications, Additions to Agenda
    - a. Public Comment (5 minutes per topic, 30 minutes maximum total)
  
  2. **Consent Agenda**
    - a. Approve Minutes from April 4, 2023 Spring Planning Work Session and Regular Session (*Patty Rosas, Page 3*)
    - b. Approve Safekeeping Agreement with Stifel, Nicolaus & Company (*Debbie Smith-Wagar, Page 11*)
    - c. Approve Addendum No. 2 to Lease with Wolf Ceramics in the Big 7 Building (*Greg Hagbery, Page 49*)
    - d. Approve Accounts Payable to Motschenbacher & Blattner LLP in the Amount of \$8,282.50 (*Debbie Smith-Wagar, Page 53*)
  
  3. **Informational Reports** (None)
  
  4. **Presentations & Discussion Items**
    - a. Wire Ropes Replacement Project Update, Joe Hampton, Hamilton Construction (*John Mann, Page 57*)
    - b. Commencing Public Process for Funding the Replacement Bridge Discussion (*Kevin Greenwood, Page 59*)
    - c. Waterfront Parking System Discussion (*Genevieve Scholl, Daryl Stafford Page 63*)
  
  5. **Executive Director Report** (*Kevin Greenwood, Page 59*)
  
  6. **Commissioner, Committee Reports**
  
  7. **Action Items**
    - a. Authorize Reading Ordinance No. 27: an Ordinance Regulating Conduct on Port Property (ORS 198) (*Daryl Stafford, Page 77*)  
*\*\*Copies of the Ordinance are available at the Port administrative office.\*\**
    - b. Approve Resolution No. 2022-23-12 Setting Waterfront Parking Rates, Rules, Fees, Zones and Hours (*Genevieve Scholl, Daryl Stafford Page 77*)
    - c. Authorize Issuance of Bid Solicitation for Miscellaneous Truss Repairs (*John Mann, Page 121*)
    - d. Approve Resolution No. 2022-23-13 Commencing Public Process for Funding Hood River White Salmon Bridge Authority Activities (*Kevin Greenwood, Genevieve Scholl, Page 215*)
  
  8. **Commission Call**
  
  9. **Confirmation of Commission Directives to Staff**
-

**10. Executive Session** - If necessary, an Executive Session may be held in accordance with: ORS 192.660(2)(a) – Employment of Public Officers, Employees & Agents, ORS 192.660(2)(b) – Discipline of Public Officers & Employees, ORS 192.660(2)(d) – Labor Negotiator Consultations, ORS 192.660(2)(e) – Real Property Transactions, ORS 192.660(2)(f) To consider information or records that are exempt by law from public inspection, ORS 192.660(2)(g) – Trade Negotiations, ORS 192.660(2)(h) - Conferring with Legal Counsel regarding litigation, ORS 192.660(2)(i) – Performance Evaluations of Public Officers & Employees, ORS 192.660(2)(j) – Public Investments, ORS 192.660(2)(n) –Security Programs, ORS 192.660(2)(n) – Labor Negotiations.

## **11. Adjourn**

If you have a disability that requires any special materials, services, or assistance, please contact us at 541,386,1645 so we may arrange for appropriate accommodations.

*The chair reserves the opportunity to change the order of the items if unforeseen circumstances arise. The Commission welcomes public comment on issues not on the agenda during the public comment period. With the exception of factual questions, the Commission does not immediately discuss issues raised during public comment. The Commission will either refer concerns raised during public comment to the Executive Director for a response or will request that the issue be placed on a future meeting agenda. People distributing copies of materials as part of their testimony should bring **10 copies**. Written comment on issues of concern may be submitted to the Port Office at any time.*

---

**THESE MINUTES ARE NOT OFFICIAL until approved by the Port Commission at the next regular meeting.**

---

### Spring Planning Work Session

**PRESENT: Commissioners:** Ben Sheppard (arrived 1:53 p.m.), Kristi Chapman, Mike Fox, Heather Gehring, and Hoby Streich. **Legal Counsel:** Kristen Campbell, and Joanna Lyons-Antley. **Staff:** Kevin M. Greenwood, Genevieve Scholl, Daryl Stafford, Debbie Smith-Wagar, Greg Hagbery, John Mann, Ryan Klapprich, and Patty Rosas. **HNTB:** Micheal Shannon. **Budget Committee:** Judy Newman, John Benton, Larry Brown, Becca Sanders, and Brian Shortt (via Zoom). **Guests:** None

**ABSENT:** None

**MEDIA:** Noah Noteboom, Columbia Gorge News

- I. **WELCOME & INTRODUCTIONS:** Vice President Kristi Chapman called the meeting to order at 12:59 p.m. and welcomed everyone to the meeting. Kevin M. Greenwood, Executive Director, proceeded with introductions.
- II. **MEETING OVERVIEW:** Greenwood provided a brief overview of today's meeting. The purpose of the planning session is to prepare for the 2023-24 Fiscal Year Budget, and discuss issues related to the Port of Hood River's ("Port") long-term sustainability. Greenwood summarized the Brainstorming Session that took place in November 2022, and identified projects that have moved forward for consideration. Greenwood also briefly reviewed sustainability goals such as the procurement of financial software that will greatly improve Port operations, and pursuing projects that will generate positive net income for the Port.
- III. **CURRENT FINANCIAL OVERVIEW:** Debbie Smith-Wagar, Finance Director, noted that the Port in the past has used a 10-year financial model to estimate future revenues and expenses to aid in long-term planning. The model for the current year has been modified to focus on individual business centers and help identify areas of opportunity for accelerated achievement of Commission goals. Smith-Wagar presented the financial reports. Some typos and errors were identified, but Smith-Wagar assured everyone that the summary report was accurate. Smith-Wagar commented that getting operations to where revenues cover their expenditures without toll revenue, is an achievable goal for most areas. The main concern is how the Port will pay for its capital needs in the future.

Smith-Wagar noted that recreation is almost always supported by property taxes, and although the Port receives approximately \$90,000 per year in property taxes, expenditures for the Event Site alone ranges from \$200,000-\$300,000 per year. Smith-Wagar added that the Port must focus on these areas and determine how to move forward and consider all options. Smith-Wagar commented that while the Port must divest from bridge toll revenues, the tolls are a fixed dollar amount and do not escalate unless there is more bridge traffic. This is another factor that must be considered, especially in operations where costs increase every year. A discussion followed regarding the bridge toll increase.

Commissioner Mike Fox referenced the summary report and inquired on whether the Rate of Return (RoR) was included in the industrial property investments. Smith-Wagar replied that the lease revenue was not included because there were too many unknowns. Greg Hagbery, Project Manager, noted that there is a Market Analysis underway that will allow for greater strategic decision making for each facility. Commissioner Fox highlighted the importance of including the RoR in their finance discussions and added that there should be a policy where Port investments include an expected RoR. Genevieve Scholl, Deputy Executive Director, asked if the RoR policy would encompass all investments or be specific to each property. Commissioner Fox replied that it should start off as a global RoR policy.

**IV. LONG-TERM FISCAL SUSTAINABILITY:** Greenwood noted that there are steps and processes that need to be instilled to work towards the Ports sustainability. These processes include a resolution Divesting from Tolls, an Annual Fee, Charges and Rates resolution, Capital Improvement List (CIL), and a Metrics and Management Process that staff will be evaluating to determine the ports sustainability moving forward. The resolution Divesting from Tolls will utilize tolls solely for bridge-related activities. A discussion ensued regarding the policy. The Annual Fees, Charges and Rates resolution will be a helpful process to review revenue generation comprehensively. Greenwood noted that staff has not identified potential fees for next year, but they will be refining the rates in the coming months and will make a final recommendation. The CIL shows all the capital or grant funded projects that are anticipated in the coming year and will allow for easy monitoring of capital projects. Commissioner Fox suggested including the Fair Market Value for each item for comparison on the CIL. Commissioner Ben Sheppard noted that the CIL does not include any items that tie back to the directives that were given to staff at Fall Planning. Greenwood will review the CIL and make sure that those items are included. Commissioner Fox suggested that the CIL should also note which projects generate revenue, and maintenance projects should be their own category.

**V. KEY ISSUES FOR FY 2023-24:**

- a. **Marina** – Daryl Stafford, Waterfront Manager, noted that staff has been working diligently to make the Marina the best they can with the funds available, but also considering the Commission’s directive to divest from bridge toll revenues. Stafford commented that facilities has taken on more work that has allowed the Port to save money by not having to contract out, but this may no longer be possible due to the shortage in facility staff.

Stafford noted that in November 2021 there was direction from the Commission to move forward with a 10% moorage increase for 3-years starting in January 2022. Stafford requested direction from the Commission on whether to continue with the 10% rate increase. Commission consensus was to proceed with the rate increase unless the rate survey indicated otherwise. Stafford also requested direction on whether to continue with the annual placeholder of \$40,000 for professional repairs. No decision was reached by the Commission and a discussion followed regarding the Marina boathouses and boat slips.

- b. **Airport** – Hagbery reported that per Commission direction the Port must develop a strategy to create additional revenue streams, while reducing overhead and waste at the airport. Staff has already started working on this goal by issuing a Request for Development Interest (RFDI). Hagbery added that this is an opportunity for greater utilization of North Apron. The Port also has an opportunity to utilize Bipartisan Infrastructure Law (BIL) funding to partially invest in constructing a new T-Hangar block on South Apron. Another strategy that is being considered is renewable energy. Staff has been working with Mid-Columbia Economic Development District (MCEDD) and Solarize Hood River to bring solar capability to the airport. This could be an opportunity to offset current electrical costs for the airport or create revenue by the development of a solar array that can sell power to other users.
- c. **Waterfront Recreation** – Greenwood emphasized that all departments and assets at the Port are managed as a team and added that the Waterfront and Event Site is not just Stafford’s issue, and that staff is there to help and support her. Greenwood turned to Stafford for a Waterfront recreation overview. Stafford noted that operations are a significant part of the success at the Waterfront and emphasized the importance of being fully staffed to prevent reduction in services. Stafford reviewed some of the proposed actions for the coming year which include raised fees,

transitioning to Text-To-Pay for parking, and adding the Hook as a paid parking area. Commissioner Fox inquired on how staff plans to manage the deficits of the waterfront and suggested working with Parks and Recreation for a solution or consider adding admission fees. Stafford replied that they need to work on their master plan, but the future of the Waterfront will depend on what happens with Lot 1 and the Maritime property. Stafford posed the question of whether the Port would like to keep assets that are not performing. Commissioner Fox commented that actions need to be taken to lead up to that recommendation. Commissioner Chapman commented that the County of Hood River is working on a possible new taxing entity that the Port could potentially benefit from, and suggested that the Port should work closely with the County and Parks & Recreation on the Waterfront issue.

- **Paid Parking System Changes:** Scholl commented that the current parking kiosk system is not well suited for the Waterfront environment and the hardware is expensive to maintain. Staff recommends transitioning to mobile payments via Text-To-Pay and mobile payment applications that would significantly reduce costs for the Port. Staff also recommends terminating trucking company parking agreements in Zone 6 and allow passenger vehicles in that Zone seven days a week. This will provide more parking for visitors near the Hook. Scholl noted that the Commission should also consider extending the paid parking Zone to include the Hook, Spit, Marina Beach, and Marina. If the Commission chooses to charge for parking at the Marina, the Port will lose eligibility for an annual maintenance grant from OSMB for approximately \$6,000 per year.

Staff also recommends that the Commission consider increasing rates and fees for parking and violations. Scholl noted that last year there was an issue where parking tickets not expensive enough to deter violations and were essentially treated as a day pass cost by some customers. Scholl added that daily parking rates should not exceed \$15 per day, as that is the apparent limit for recreational immunity. Staff would also like to change the payment processing for parking tickets to allow for customers to pay their tickets at the Port office instead of utilizing Professional Accounts Management (“PAM”) to process payments. Scholl added that the Commission should also discuss whether the seasonal staffing of the Event Site parking booth should continue. A discussion ensued regarding the Event Site annual passes. Commissioner Chapman suggested linking the annual passes to a specific vehicle so that they are not transferable. There was consensus from the Commission to move forward with a resolution of all Waterfront recommendations for Commission approval.

- d. **Developable Land** – Hagbery reported that one proposal was received for the development of Lot 1, and a recommendation will be provided to the Commission at the next meeting. A market analysis is also underway at Lower Mill, the report is expected to be completed in approximately 3 months. Commissioner Sheppard expressed his concern that the Lot 1 design may not meet Oregon Department of Transportation (ODOT) requirements, and requested that this be researched further. The Commission directed staff to follow up with ODOT on any potential updates or changes to their traffic requirements, as well as updating the Interchange Area Management Plan (IAMP). A discussion ensued regarding the development of Lot 1.
- e. **Existing Buildings** – Hagbery noted that the light industrial assets are doing better than the commercial properties. Marina #2 is a commercial building that is leased to the Department of Motor Vehicles (DMV) that is underperforming. Their lease will be expiring soon, giving the Port an opportunity to restructure their lease. Marina #1 is another commercial building that is

underperforming. A portion of the Marina #1 building is unleased and is being considered as a potential new location for the Port office. A discussion followed regarding the possibility of development at the Marina.

- f. **Existing Bridge** – John Mann, Facilities Director, presented a list of projects recommended by the engineers that should not be pushed out on the bridge Capital Improvement Plan (CIP). Some of the items on the list include maintenance painting, scour evaluations, and rehab live loads. Commissioner Fox suggested decommissioning the lift span early to avoid some additional maintenance costs and requested that staff research if this is at all feasible.
  
- g. **Bridge Replacement** – Michael Shannon, HNTB Project Manager, reported that the Replacement Bridge Management Contract (RBMC) will end on June 30, 2023. The RBMC will be working with the Bi-State Working Group (BSWG) and Staff to develop a 3-year work plan and budget. Funding for the 3-year work plan will come from existing and future grant funding on the project. Shannon provided a brief update on current funding for the bridge replacement project.
  
- h. **Administration and Central Services**
  - **Staffing for Adequate Service Levels:** Scholl noted that the Port is experiencing a critical need for staff, specifically in the facilities department. Scholl presented recommendations to the Commission that will help with employee recruitment and retention. The first recommendation is to implement an increase in wage levels for non-management staff in all departments. The increase would address competitive wages within the private sector.

Another recommendation is to implement and incentivize career-track professional development and skills training programs for all positions. Staff also recommends improving paid time off policies and consider offering 4-day work week options, as well as adding 3 federally recognized holidays that are currently not observed at the Port. Commuter benefits or assistance should also be considered. Of the 32 current Port employees, 50% live outside of Hood River, with an average 30-mile daily commute to and from work.

Staff also suggests enhancing recruitment outreach activities to area high schools and colleges, as well as offering hiring bonus options. Hiring bonuses are currently not allowed for government entities, but there is legislation currently pending that would allow government employers to provide bonuses. The Port should also improve and ensure hiring opportunities in the Spanish-speaking community.

The Commission should also consider moving towards automation during off-peak hours at the toll booth between 10 p.m. and 6 a.m. This action would bring the required staffing levels to the current level and avoid the need to recruit graveyard shift workers. Staff has already scheduled for a two-month pilot project starting May 1 if the Commission approves.

Finally, staff recommends including some public safety, parking enforcement, and building security response duties in a potential contract with an outside security services firm. This would help alleviate the need to recruit and hire parking enforcement personnel.

Commissioner Fox likes the idea of increasing education for Port employees, and would like to see wages based on performance. Commissioner Fox also believes that increasing wages is not always the answer, and creating a fun, challenging, and rewarding work environment

could help retain employees. Commission consensus was for staff to present a proposal of all proposed staffing recommendations.

- **Financial Software Procurement for Proper Allocation:** Smith-Wagar noted that the new proposed financial software will include more online options such as customers paying online. Larry Brown, Budget Committee, inquired on the time frame to implement the new software. Smith-Wagar replied that it would take approximately 1 year.

**VI. Other:** None

The meeting was adjourned at 4:45 p.m.

**SIGNED:**

---

Ben Sheppard, President

**ATTESTED:**

---

Michael Fox, Secretary

This page intentionally left blank.



---

**THESE MINUTES ARE NOT OFFICIAL until approved by the Port Commission at the next regular meeting.**

---

### Regular Session

**PRESENT: Commissioners:** Ben Sheppard, Kristi Chapman, Hoby Streich, Mike Fox, and Heather Gehring. **Legal Counsel:** Kristen Campbell. **Staff:** Kevin M. Greenwood, Genevieve Scholl, Debbie Smith-Wagar, Daryl Stafford, John Mann, Greg Hagbery, Ryan Klapprich, and Patty Rosas. **HNTB:** Michael Shannon, and Brian Munoz. **Guests:** Grant Polson

**ABSENT:** None

**MEDIA:** None

**1. CALL TO ORDER:** President Ben Sheppard called the meeting to order at 4:57 p.m.

a. **Modifications or additions to the agenda:**

1) Move Action Item 7(a) to Executive Session.

b. **Public Comment:** Written public comment included in the packet.

**2. CONSENT AGENDA:**

- a. Approve Minutes from March 21, 2023 Regular Session
- b. Approve Lease with Hood Aero in the Bow Hangar at the Airport
- c. Approve Operations Agreement with Hood River Soaring at the Airport
- d. Approve Amendment to Goods & Services Agreement with Duncan Solutions for Paid Parking System on the Waterfront
- e. Approve Task Order 1 with Radcomp for Port Server Migration and Upgrade
- f. Approve Accounts Payable to Campbell Phillips in the Amount of \$14,270
- g. Approve Accounts Payable to Jaques Sharp in the Amount of \$2,285
- h. Approve Accounts Payable to McCarthy Law, LLC in the Amount of \$2,635

**Motion:** Approve consent agenda.

**Move:** Mike Fox

**Second:** Heather Gehring

**Discussion:** None

**Vote:** **Aye:** Ben Sheppard, Kristi Chapman, Mike Fox, Hoby Streich, Heather Gehring

**MOTION CARRIED**

**3. INFORMATIONAL REPORTS:** None

**4. PRESENTATIONS & DISCUSSION ITEMS:** None

**5. EXECUTIVE DIRECTOR REPORT:** None

**6. COMMISSIONER, COMMITTEE REPORTS:** None

**7. ACTION ITEMS:**

a. ~~Approve Resolution No. 2022-23-11 Establishing Toll Revenue Use Policy~~

**8. COMMISSION CALL:**

- a. Commissioner Sheppard noted that an email regarding an Executive Director evaluation will be sent out to the Commissioners for review. Commissioner Streich requested copies of evaluations that were conducted in previous years.

**9. CONFIRMATION OF DIRECTIVES:** None

**10. EXECUTIVE SESSION:** President Ben Sheppard recessed Regular Session at 5:00 p.m. to call the Commission into Executive Session under ORS 192.660 (2)(f) to consider information or records that are exempt from disclosure by law, including written advice from legal counsel and ORS 192.660 (2)(h) to consult with legal counsel regarding legal rights and fees.

**11. POSSIBLE ACTION:** The Commission was called back into Regular Session at 6:20 p.m. The following action was taken as a result of Executive Session:

a. **Approve Resolution No. 2022-23-11 Establishing Toll Revenue Use Policy.**

**Motion:** Approve Resolution No. 2022-23-11 setting the goal of operating all non-bridge related activities without toll revenue by no later than June 30, 2028.

**Move:** Mike Fox

**Second:** Heather Gehring

**Discussion:** None

**Vote:** **Aye:** Ben Sheppard, Kristi Chapman, Mike Fox, Hoby Streich, Heather Gehring

**MOTION CARRIED**

**12. ADJOURN:** The meeting was adjourned by unanimous consent at 6:22 p.m.

**ATTEST:**

---

Ben Sheppard, President

---

Michael Fox, Secretary

# Commission Memo



Prepared by: Debbie Smith-Wagar, Finance Director  
Date: April 18, 2023  
Re: Stifel Safekeeping Agreement

---

The Port has purchased investments through Vining Sparks, an investment banking company which was purchased in 2021 by Stifel, Nicolaus & Company. We need a new agreement with Stifel for them to hold the Port's investments. Stifel is currently holding \$1,820,000 (par value) for the Port. The Port is restricted by state law and the Port's own investment policy as to what types of investments it can own; the investments at Stifel include US federal agency debt obligations, municipal bonds, and a corporate bond rated AA-.

This agreement needs to be signed by the Commission President. It has been reviewed by legal counsel.

**RECOMMENDATION:** Approve Safekeeping Agreement with Stifel, Nicolaus & Company.

This page intentionally left blank.

STIFEL

SAFEKEEPING AGREEMENT



# TABLE OF CONTENTS

1. General Agreement .....	1	Safekeeping Agreement Signature Document .....	20
2. Definitions.....	1	Certified Copy of Certain Resolutions Adopted By the Board of Directors Whereby the Establishment and Maintenance of Security Accounts Have Been Authorized .....	21
3. Stifel Services as Safekeeper.....	2	Sophisticated Municipal Market Professional Certification .....	22
4. Property Held in the United States.....	2	Institutional Investor Certification .....	22
5. Property Held Outside the United States.....	3	Automatic Cash Investment Services Election .....	22
6. Rule 15c3-3 of the Exchange Act.....	4	Substitute IRS Form W-9 – Tax Certification .....	22
7. Orders and Executions .....	4	Arbitration .....	22
8. Trading Away/Step Out Trades.....	5	Schedule A - Fee Schedule .....	25
9. Money Market Mutual Funds.....	5	Business Continuity Notification.....	26
10. Tax Services .....	6	Stifel’s Privacy Notice.....	27
11. Proper Instructions.....	7		
12. Actions Permitted Without Express Authority .....	8		
13. Records.....	8		
14. Confirmations and Statements .....	9		
15. Settlement Procedures .....	9		
16. Stifel’s Standard of Care; Exculpation.....	10		
17. Compensation of Stifel .....	10		
18. Disclaimer of Liability and Indemnification .....	11		
19. Effective Period and Termination.....	12		
20. General.....	13		
21. U.S. Special Resolution Regimes and Insolvency Proceedings.....	16		
22. Affirmative Tax Consent.....	17		
23. Arbitration .....	18		
24. Waiver of Rights to Trial by Jury.....	19		
25. Forum Selection Clause.....	19		





# INSTITUTIONAL SAFEKEEPING AGREEMENT

## 1. General Agreement.

This safekeeping agreement (“**Safekeeping Agreement**”) sets forth the respective terms, conditions, rights, and obligations of Stifel, Nicolaus & Company, Incorporated (“**Stifel**”) and you in connection with certain safekeeping services provided by Stifel relating to securities and other of your assets (“**Safekeeping Services**”) as outlined in this Safekeeping Agreement and any user guides, documents, questionnaires, bulletins, reference materials, policies (and other instructions), manuals, exhibits, appendices, schedules, supplements, and addendums that apply in connection with the products and services applicable to this Safekeeping Agreement (“**Safekeeping Service Documents**”). All Safekeeping Service Documents are incorporated and made part of this Safekeeping Agreement. Unless the context otherwise requires, all references to the Safekeeping Agreement include all Safekeeping Service Documents.

Stifel is willing to provide the services upon the terms contained in this Safekeeping Agreement and reserves the right to amend or terminate this Safekeeping Agreement at any time. Stifel is not responsible for any duties or obligations not specifically contemplated under this Safekeeping Agreement or any Safekeeping Service Documents. (This Safekeeping Agreement and any applicable Safekeeping Service Document is subject to Stifel’s approval and may be amended or further supplemented from time to time. This Safekeeping Agreement and any Safekeeping Service Document supersedes any previous agreements made by you with Stifel relating to any safekeeping services offered by us. Stifel reserves the right to decline any request to open a safekeeping account for any reason or no reason.

For purposes of this Safekeeping Agreement, “**you**” or “**your**” means each natural person or legal entity indicated in the title to the Account and on whose behalf this Agreement has been signed. Your “**Account(s)**” refers to each safekeeping or similar account at Stifel that is established in your name alone, or in your name together with others under this Safekeeping Agreement, including, but not limited to, additional accounts that Stifel may open for you at your election for a variety of reasons (e.g., operational convenience, pledge accounts or similar accounts, accounts for segregating assets and services, etc.). In establishing your Account(s), you agree to complete the Safekeeping Agreement signature page and the Account Registration Instructions Form. The information you provide will apply to these additional Accounts, and you may receive reporting on your accounts on a consolidated basis as permitted under Applicable Law (as defined below). You understand and agree that you have inquired into Stifel’s ability to provide the Safekeeping Services

contemplated by this Safekeeping Agreement to you, and you have concluded that such arrangement does not violate Applicable Law. Stifel shall have no duty to inquire as to the legality under Applicable Law of our ability to provide the services to you contemplated by this Safekeeping Agreement, including, but not limited to, situations involving municipal or similar-type entities.

You may be charged execution charges (such as commissions, commission equivalents, mark-ups, mark-downs, and spreads) as described in this Safekeeping Agreement.

2. **Definitions.** In addition to terms defined elsewhere in this Safekeeping Agreement, including any Safekeeping Service Documents terms defined in the UCC (as defined below) have the same meanings herein as therein, and the following other terms have the following meanings for purposes of this Safekeeping Agreement and a Safekeeping Service Document unless provided otherwise therein:
  - a. “**1940 Act**” means the Investment Company Act of 1940, as amended from time to time.
  - b. “**Affiliate**” means an entity that is directly or indirectly controlling, controlled by, or under common control with a party to this Safekeeping Agreement, as applicable.
  - c. “**Applicable Law**” means: (i) the rules and regulations of the U.S. Securities and Exchange Commission (“**SEC**”); U.S. securities exchanges; the Financial Industry Regulatory Authority, Inc. (“**FINRA**”); and self-regulatory organizations (“**SROs**”); U.S. federal and state securities laws; other applicable U.S. federal, state, and local laws and regulations, including, without limitation, the U.S. Internal Revenue Code of 1986, as amended (the “**Code**”) and, where applicable, the Employee Retirement Income Security Act of 1974, as amended (“**ERISA**”); (ii) applicable laws, rules, regulations, and market practice of any non-U.S. jurisdiction; and (iii) applicable rules, regulations, customs, and provisions of the constitution (or comparable document) of any exchange, electronic communication network, securities association, alternative trading system, market, clearing system, clearinghouse, or depository, as any of (i)-(iii) are in effect from time to time.
  - d. “**Authorized Person(s)**” means any person listed on the Entity Account Resolution included in the Safekeeping Agreement signature page, as may be amended or updated from time to time.
  - e. “**Business Day**” means any day on which the New York Stock Exchange is open for trading (even if on an abbreviated schedule).

- f. **“Exchange Act”** means the Securities Exchange Act of 1934, as amended.
- g. **“Losses”** or **“Loss”** means losses, claims, actions, suits, proceedings, demands, damages, liabilities, and expenses, including reasonable attorney’s fees, or costs as they are incurred, and subject to the Limitation of Liability provision set forth herein.
- h. **“Proper Instructions”** means instructions in accordance with Section 11 received by Stifel from you or an Authorized Person listed on the Entity Account Resolution included in the Safekeeping Agreement signature page. The term includes standing instructions.
- i. **“Property”** means securities and other of your assets that Stifel agrees to treat as financial assets for purposes of the UCC.
- j. **“Rule 15c3-3”** means Rule 15c3-3 of the Exchange Act.
- k. **“SEC”** means the United States Securities and Exchange Commission.
- l. **“Securities Act”** means the Securities Act of 1933, as amended.
- m. **“Stifel,” “we,” “us,”** or **“our”** means Stifel, Nicolaus & Company, Incorporated, its partners, officers, directors, branch managers (or persons occupying a similar status or performing similar functions), employees, contractors, agents, and, as applicable, any natural persons that would be associated persons of Stifel under the federal securities laws.
- n. **“UCC”** means the Uniform Commercial Code of the State of New York as in effect from time to time.
- o. **“United States Securities System”** means a “clearing agency,” as defined in Section 3(a)(23) of the Exchange Act that is registered or exempt from registration under Section 17A(b) of that Act.

### 3. Stifel Services as Safekeeper.

- a. **General.** You hereby appoint Stifel as safekeeper of the Property that Stifel in its sole discretion determines to accept and safekeep. You agree to deliver to Stifel all Property that you desire Stifel, and that Stifel is willing, to treat as a financial asset for purposes of the UCC and all cash and other proceeds of the securities and financial assets held in safekeeping under this Safekeeping Agreement. Unless otherwise noted by Stifel, all Property that you provide to Stifel for safekeeping will be treated as a financial asset under the UCC. This Safekeeping Agreement does not require Stifel to accept any and all assets for safekeeping, nor does it require Stifel to treat any specific asset as a financial asset for purposes of the UCC. Stifel will not accept safekeeping of, or otherwise process in any way, bearer securities. Except as otherwise provided herein,

Stifel shall be responsible for the safekeeping of the Property received by it pursuant to this Safekeeping Agreement as required by Applicable Law. Stifel is not responsible for any Property delivered by you to Stifel until such Property is actually received by Stifel.

- b. **Sub-Safekeepers.** In acting as safekeeper, Stifel may appoint (i) one or more banks, trust companies, or other financial institutions or other entities located in the United States to act as a sub-safekeeper for the purposes of your Property in furtherance of this Safekeeping Agreement; or (ii) a United States Securities System in which Stifel or a sub-safekeeper participates. Stifel will not be responsible or liable for any Losses by you or your Authorized Persons or any persons claiming through you arising as a result of (x) the insolvency of a sub-safekeeper or United States Securities System, except in the case of a sub-safekeeper to the extent such Losses are a direct result of Stifel’s gross negligence or willful misconduct in exercising reasonable care in its selection of such sub-safekeeper, or (y) the deposit or maintenance of Property at a sub-safekeeper specified by you or any of your Authorized Persons. Stifel may, at any time in its discretion, terminate the use of any sub-safekeeper, or United States Securities System.
- c. **Relationship.** With respect to securities and other financial assets, Stifel is a securities intermediary and you are the entitlement holder. Stifel agrees to treat as a financial asset any cash received by Stifel for your Account. The duties of Stifel as securities intermediary set forth in the UCC are varied by the terms of this Safekeeping Agreement to the extent that the duties may be varied by agreement under the UCC.

### 4. Property Held in the United States.

- a. **Holding Securities.** Unless otherwise agreed to in writing, Stifel will hold the Property in nominee name. Upon receipt of Proper Instructions on your behalf, Stifel shall establish and maintain a segregated account or accounts for you and on your behalf and into which account or accounts Property may be transferred. Stifel shall hold and segregate for your account all Property held by Stifel in the United States, to the extent not maintained in a United States Securities System.  
  
Stifel shall not be responsible for any of your Property that is not received by Stifel or which are not delivered in accordance with Proper Instructions. Stifel shall not be responsible for the title, validity, or genuineness of any Property received by Stifel or delivered by Stifel pursuant to this Safekeeping Agreement.
- b. **Collection of Income.** With respect to the Property being held as provided in Section 3, Stifel shall collect on a timely basis all income and other payments with respect to the securities and other financial assets and

to which you shall be entitled either by law or pursuant to custom in the securities business. Stifel shall present for payment all income items requiring presentation as and when they become due and shall collect interest when due on the Property. Stifel shall credit income to you as such income is received or in accordance with Stifel's then current payable date income schedule. Any credit to you in advance of receipt may be reversed when Stifel determines that payment will not occur in due course, and you may be charged at Stifel's applicable rate for time credited. Any cash in your Accounts will be treated in accordance with your instructions on the Safekeeping Agreement signature page. If you do not make a selection on the Safekeeping Agreement signature page, all cash will be held as free credit balances without earning any interest. You understand and agree that your selection in the Automatic Cash Investment Services Election on the Safekeeping Agreement signature page on page 20 meets your investment policy. Stifel has no responsibility to monitor or oversee your Cash Investment Services Election.

c. **Delivery Out.** Stifel shall release and deliver out your Property held in a United States Securities System only upon receipt of Proper Instructions on your behalf, specifying the Property to be delivered out and the person or persons to whom delivery is to be made. Unless otherwise agreed, cash shall be treated in accordance with the selections you make on the Safekeeping Agreement signature page. Any payouts outside of the methods contemplated on the Safekeeping Agreement signature page, other than to settle transactions in securities, will be subject to any additional requirements that Stifel may impose.

d. **Proxies.** Stifel shall forward or cause to be forwarded all proxies, proxy soliciting materials, and other relevant issuer communications relating to the Property. Stifel has no other duty to act on such proxies, proxy solicitation materials, or relevant issuer communications. It is your responsibility to forward or cause to be forwarded any such proxies, proxy solicitation materials, or other relevant issuer communication to your client, and Stifel is not liable for any failure on your part to provide such materials to your customer as applicable.

e. **Callable Securities.** When Stifel holds on your behalf Property that is callable in whole or in part, you agree to participate in an impartial lottery allocation system of the called securities in which the probability of your securities being selected as called is proportional to the holdings of the securities of all other customers of Stifel that are held in bulk by or for Stifel. You further understand that Stifel will withdraw such securities from any sub-safekeeper prior to the first date on which they become callable unless the sub-safekeeper has adopted an impartial

lottery system that is applicable to all participants. You understand and agree that Stifel may change its allocation methodology at any time. You may access Stifel's allocation procedures at [www.stifel.com/docs/pdf/disclosures/CallableSecurities.pdf](http://www.stifel.com/docs/pdf/disclosures/CallableSecurities.pdf) or by requesting a copy from the Stifel representative with whom you regularly interact regarding your Account.

f. **Ownership of Securities; Security Interest.** Except as otherwise agreed, you represent and warrant to Stifel that either you own the Property in the Account free and clear of all liens, claims, security interests, and encumbrances (except those granted herein), or if the Property is owned beneficially by others, you have the right to pledge such Property to the extent necessary to secure your and the beneficial owner's obligations hereunder, free of any right of redemption or prior claim by the beneficial owner. Stifel's security interest pursuant to this Section shall be a first lien and security interest subject to no setoffs, counterclaims, or other liens prior to or on a parity with it in favor of any other party (other than specific liens granted preferred status by statute), and you shall take any and all additional steps that Stifel requires to ensure such priority and status, including notifying third parties or obtaining their consent to Stifel's security interest. With respect to Accounts established in the name of third parties, you represent and warrant to Stifel that you have been duly authorized to enter into and perform all transactions contemplated hereby and to take actions and give Proper Instructions with legal and binding effect upon such third parties and their respective Accounts.

In order to secure repayment of your and each third party's obligations to Stifel hereunder, you hereby pledge and grant to Stifel a continuing lien and security interest and right of setoff against all of your right, title, and interest in and to (i) all Accounts in your name and the Property now or hereafter held in such Accounts (including proceeds thereof), (ii) each Account in respect of which or for whose benefit the advance, overdraft, or indebtedness relates and the Property now or hereafter held in such Accounts (including proceeds thereof), and (iii) any other property at any time held by it for your Account. In this regard, Stifel shall be entitled to all of the rights and remedies of a pledgee under common law and a secured party under the UCC and any laws or regulations then in effect.

5. **Property Held Outside the United States.** Foreign securities and other financial assets held outside of the United States are not covered by this Safekeeping Agreement. This Safekeeping Agreement may be amended, or a Safekeeping Service Document may be added, if the services covered by this Safekeeping Agreement for foreign securities and other financial assets are offered in the future.

6. **Rule 15c3-3 of the Exchange Act.** Under Rule 15c3-3 of the Exchange Act, Stifel is required to obtain and, thereafter, to maintain possession or control of customer fully paid securities and excess margin securities, as such terms are defined in that rule. If Stifel determines that it does not have sufficient securities under its possession or control as required (such a condition is referred to as a segregation deficiency), it is required by that rule to take certain steps to obtain possession or control, including, without limitation, recalling securities from loans, and is permitted the period of time set forth in that rule in which to obtain possession or control. To the extent that Stifel has a segregation deficiency in shares over a record date for a vote, dividend, or other corporate action or distribution, Stifel will either (a) allocate such deficiency to the client(s) to whom such a deficiency is attributed (if any); or (b) if the deficiency cannot practically be attributed to any particular client, allocate such deficiency to its clients using a random impartial lottery. You understand and agree that Stifel may change its allocation method at any time. The clients to whom such deficiency is allocated will be unable to vote or give consent in respect of such corporate action.

## 7. Orders and Executions.

a. **Responsibility to Accept or Reject Trades.** Stifel shall execute transactions in Accounts and release or deposit money or securities to or for Accounts only upon Proper Instructions as defined in Section 11. Notwithstanding any Proper Instructions to the contrary, Stifel may, after notifying you orally or in writing, (i) cancel a confirmation or refuse to confirm a transaction; (ii) reject a delivery or receipt of Property; (iii) refuse to clear a trade executed by you; or (iv) refuse to execute a trade for an Account. You agree that you are responsible for ensuring that your Account has enough cash to cover any transactions in securities entered into by you or an Authorized Person.

### b. Best Execution.

i. *Non-Directed Orders.* In accordance with Applicable Law, Stifel shall use reasonable diligence to achieve best execution for orders routed to Stifel for order handling, execution, or both ("*Non-Directed Orders*"). Stifel will timely provide to you a report, file, or other evidence that shall be intended to demonstrate to any applicable regulator that Stifel has sought to use reasonable diligence to achieve best execution for such Non-Directed Orders in the aggregate. You acknowledge that you are, and shall remain responsible for, regularly and rigorously reviewing Non-Directed Orders for best execution.

ii. *Directed Orders.* As further discussed in Section 8, you may provide instructions directing Stifel to place orders for Accounts for execution with third-party

broker-dealers ("*Non-Stifel Brokers*"), or may place such orders directly with Non-Stifel Brokers for Accounts ("*Directed Orders*").

iii. *Your Acknowledgments.* You agree and acknowledge that:

1. Stifel and its Affiliates are not responsible for (1) the execution of Directed Orders; or (2) the transmission of Directed Orders placed directly with Non-Stifel Brokers;
2. You are fully responsible for resolving any disputes and for bearing any and all Losses resulting from transactions in Directed Orders; and
3. You are responsible for sending, or causing any Non-Stifel Broker you use, to send trade, settlement, and allocation instructions for transactions in Directed Orders to Stifel in accordance with Stifel's procedures.

iv. *Stifel Acknowledgments.* Stifel agrees and acknowledges that, with respect to transactions in Directed Orders reported to Stifel, it will act in good faith to provide safekeeping services for such transactions, if requested by you, and, to the extent possible, clear and settle such transactions. You may provide Stifel with a self-affirmation for transactions executed by a Non-Stifel Broker.

c. **Trade Errors.** You are responsible for transmission to Stifel of all orders and for any errors in your recording or transmission of such orders, whether such orders were placed verbally, electronically, or in writing. Stifel requires that outstanding positions (i.e., buy/sell transactions) be covered prior to the market's close on the same business day that an error is realized. If an error is realized after the market has closed, it must be covered by the next business day. A transaction that was executed in error must be canceled from the applicable Account. All debits must be covered on the settlement date. You are responsible for any deficiency remaining and satisfying any debit or obligation. You will pay for trade errors that result in a deficit when such errors are the direct responsibility of you. You agree and acknowledge that Stifel may debit (and as necessary liquidate positions in) the relevant Account at Stifel or Stifel's Affiliates if any Losses result from Stifel having to correct, liquidate, complete, or cancel any trade that is effected on behalf of an Account under this Safekeeping Agreement.

d. **Restricted and Control Stock Requirements.** You are responsible for (i) determining whether any securities held in any Account are restricted or control securities under Applicable Law and (ii) ensuring that such orders in restricted or control securities have been held for the requisite holding period and that such execution of or transaction in such control or restricted securities is in compliance with Applicable Law. If you intend to

purchase a privately offered security pursuant to Rule 144A, under the Securities Act (17 C.F.R. § 230.144A), you agree to complete and provide Stifel with a final copy of the Certificate of Rule 144A Qualified Institutional Buyer and Section 3(C)(7) Qualified Purchaser form.

**e. Corporate Action Requests/Soliciting Dealer Agreements.** You request and authorize Stifel to execute, as your agent-in-fact, all soliciting dealer agreements for corporate actions involving securities or other interests held by you on the books of Stifel. Stifel agrees to (i) provide written notice of the pending corporate action to you at your designated locations; (ii) collect and submit corporate action requests from you and submit them to the soliciting party in accordance with the instructions received from that party; and (iii) use commercially reasonable efforts to communicate corporate action information to you, but shall not be liable for (y) any delays in the communication of corporate action information; or (z) delays in the transmission of collected corporate action requests to the soliciting party unless caused by Stifel's gross negligence. All fees received from the soliciting party will be credited to you. You shall be responsible for all solicitation activity among you, your agents, and Authorized Persons.

**8. Trading Away/Step Out Trades.**

- a. Where you execute a transaction with a Non-Stifel Broker and advise Stifel that such transaction will be settled and cleared by Stifel, you understand that Stifel may have entered into an agreement with third parties that require Stifel to settle and clear such transactions on your behalf. In such cases, you understand and acknowledge that the transactions entered into by you are considered "locked in" and cannot be reversed, cancelled, or changed. You agree to accept all responsibility for Losses incurred because of such transactions, and you understand and agree that Stifel may charge your Accounts and Property for such transactions and Losses.
- b. Where you elect to direct trades to a Non-Stifel Broker, you agree and acknowledge that you have no right to reverse, cancel, or change transactions that have been executed by a Non-Stifel Broker that have been cleared and settled by Stifel, notwithstanding any agreement or understanding between Stifel and the Non-Stifel Broker.
- c. You agree that Stifel has sole discretion to accept transactions for settlement or clearance in your Account(s) or to reject, reverse, or cancel transactions. You agree to accept the result of Stifel's actions regarding such transactions and to pay for Losses that result from such transactions. Stifel has no obligation to you to attempt to correct your error in your transaction that is executed

with a Non-Stifel Broker. You accept full responsibility for any such errors and agree to pay for such errors. Stifel is authorized to charge your Account(s) for errors in transactions executed away from Stifel.

- d. You agree that Stifel shall have no responsibility for monitoring transactions executed away from Stifel by you for your Account(s) regardless of the size of the transaction (by dollar amount or number of shares).
- e. You agree to ensure that you and the Non-Stifel Broker immediately provide reporting to Stifel of transactions executed away that are intended to be settled by Stifel.
- f. You represent and warrant that you will receive confirmations of any transactions executed by a Non-Stifel Broker from that broker.

**9. Money Market Mutual Funds.** If applicable, you understand and agree the following with respect to a purchase, redemption, or exchange ("**Money Fund Trade**") in a money market mutual fund registered under the 1940 Act ("**Money Fund**") and changes to Money Fund Trades ("**Modification**").

- a. **Acceptance.** A Money Fund Trade or Modification is only deemed accepted once it is received in proper form by the Money Fund (not Stifel) and will be priced at the Money Fund's net asset value ("**NAV**") next determined after it is accepted by the Money Fund. You understand and acknowledge that Stifel does not serve as dealer, agent, or designee for purposes of Rule 22c-1 under the 1940 Act for the receipt and transmission of a Money Fund Trade or a Modification. Stifel is not liable to you for any Losses connected with a Money Fund's rejection of a Money Fund Trade or Modification.
- b. **Pre-Close Windows.** Money Fund Trades and Modifications may be subject to a pre-close window (sometimes referred to as a soft-close) prior to such Money Fund's NAV strike time. As applicable, if you place an order within the "pre-close window," you may, at Stifel's sole discretion, be prompted to roll your Money Fund Trade for the Money Fund to the NAV strike time following the NAV strike time corresponding to such pre-close window, which in some cases, may be the next Business Day. If during a pre-close window you wish to receive the NAV corresponding to the pre-close, Stifel will attempt to facilitate having your order receive the next-calculated NAV, but can not guarantee it. A Money Fund's pre-close window may change without prior notice. Certain floating NAV ("**FNAV**") Money Funds may have multiple NAV strike times intraday, and as a result, such Money Funds will have multiple pre closes throughout the day. For more information regarding a Money Fund's soft-close window, please contact your Stifel representative.

c. **Fees and Gates.** Your ability to submit a Money Fund Trade or a Modification may not be available if a Money Fund imposes a liquidity fee (“**Fee**”) or redemption gate (“**Gate**”), as described in the Money Fund’s prospectus, including when a Money Fund changes or lifts a previously imposed Fee or Gate. All Money Fund Trades received by a Money Fund (not Stifel) after the effective time and date of the Fee or Gate will be subject to the Fee or Gate regardless of when a Money Fund Trade was placed with Stifel. Consult the respective Money Fund’s prospectus for important information regarding Fees or Gates. Stifel is not liable for any Losses arising from the imposition of a Fee or Gate by a Money Fund. Stifel may request additional information to verify the identity of any account or beneficial owner as a “retail” or “natural” person, consistent with applicable federal securities laws. In addition, you agree and acknowledge that a Money Fund may take measures to involuntarily redeem Money Fund shares as may be required by law or otherwise permitted and disclosed in each Money Fund’s prospectus.

## 10. Tax Services.

a. **General.** When reporting your taxes, please rely on the substitute Form 1099 you will receive from Stifel after year-end for your taxable accounts. (For Retirement Accounts, Form 1099R will report distributions from the account rather than income and dividends or proceeds from sales.) Stifel does not provide tax advice concerning your Account(s), and you agree to consult with your own tax advisor concerning any tax implications that may arise as a result of activity in your Account.

b. **Authorizations.** Stifel is authorized to deduct from any cash received or credited to your Account any taxes or levies required by any tax or other governmental authority having jurisdiction in respect of your transactions and to disclose any information required by any such tax or other governmental authority in relation to processing any claim for exemption from or reduction or refund of any taxes relating to your transactions and holdings.

c. **Services Further Limited.** Other than the servicing responsibilities provided herein, Stifel shall have no responsibility or liability for any obligations now or hereafter imposed on you or Stifel as safekeeper of your assets by the tax law of any country or of any state or political subdivision thereof. Stifel is not your tax adviser or tax counsel. You will be responsible for payment of any and all taxes that may be due as a result of transactions in your Account.

### d. Tax Information.

i. *Form W-9.* For your convenience, Stifel is providing the General Instructions to Form W-9 that are

available on the Internal Revenue Service (“IRS”) website at [www.irs.gov](http://www.irs.gov). These general instructions cover the purpose of the W-9 form as well as specific instructions for properly filling out the form. Stifel provides various versions of the W-9 that are considered to be a “substitute W-9,” and per the IRS W-9 instructions, “If a requester gives you a form other than Form W-9 to request your TIN, you must use the requester’s form if it is substantially similar to the Form W-9.” Please read the instructions carefully and provide either the actual W-9 or the appropriate “substitute W-9” that Stifel has provided to ensure the account is opened correctly. Form W-9 should only be used if you are a U.S. person (including resident alien).

What Is Backup Withholding? – Persons making certain payments to you must withhold and pay to the IRS 30% of such payments under certain conditions. This is called “backup withholding.” Payments that may be subject to backup withholding include interest, dividends, broker and barter exchange transactions, and royalties. If you give the requester your correct Tax Identification Number (“TIN”), make the proper certifications, and report all your taxable interest and dividends on your tax return, payments you receive will not be subject to backup withholding. Payments you receive will be subject to backup withholding if: 1. you do not furnish your TIN to the requester, or 2. the IRS tells the requester that you furnished an incorrect TIN, or 3. the IRS tells you that you are subject to backup withholding because you did not report all your interest and dividends on your tax return (for reportable interest and dividends only), or 4. you do not certify to the requester that you are not subject to backup withholding under 3 above (for reportable interest and dividend accounts opened after 1983 only), or 5. you do not certify your TIN when required.

### ii. Penalties.

1. Failure to Furnish TIN – If you fail to furnish your correct TIN to a requester, you are subject to a penalty of \$50 for each such failure unless your failure is due to reasonable cause and not to willful neglect.
2. Civil Penalty for False Information With Respect to Withholding – If you make a false statement with no reasonable basis that results in no backup withholding, you are subject to a \$500 penalty.
3. Criminal Penalty for Falsifying Information – Willfully falsifying certifications or affirmations may subject you to criminal penalties including fines and/or imprisonment.

4. Misuse of TINs – If the requester discloses or uses TINs in violation of federal law, the requester may be subject to civil and criminal penalties.
- iii. *Privacy Act Notice.* Section 6109 of the Internal Revenue Code requires you to give your correct TIN to persons who must file information returns with the IRS to report interest, dividends, and certain other income paid to you. The IRS uses the numbers for identification purposes and to help verify the accuracy of your tax return. The IRS may also provide this information to the Department of Justice for civil and criminal litigation and to cities, states, and the District of Columbia to carry out their tax laws. You must provide your TIN whether or not you are required to file a tax return. Payers must generally withhold 30% of taxable interest, dividend, and certain other payments to a payee who does not give a TIN to a payer. Certain penalties may also apply.
- iv. *Substitute IRS Form W-9.* Tax Certification – Under penalties of perjury, you certify that: 1) the number you have included in this Safekeeping Agreement is your correct taxpayer identification number (or you are waiting for a number to be issued); 2) you are not subject to backup withholding because: a) you are exempt from backup withholding, b) you have not been notified by the IRS that you are subject to backup withholding as a result of a failure to report all interest and dividends, or c) the IRS has notified you that you are no longer subject to backup withholding; 3) you are a U.S. Citizen or other U.S. person (as defined in general instructions); and 4) You certify that you are exempt from FATCA reporting on your Account(s) held at Stifel. Certification Instructions: You must cross out item 2 above if you have been notified by the IRS that you are currently subject to backup withholding because you have failed to report all interest and dividends on your tax return. For real estate transactions, item 2 does not apply. For mortgage paid, acquisition or abandonment of secured property, cancellation of debt, contributions to an individual retirement arrangement (“IRA”), and generally payments other than interest and dividends, you are not required to sign the certification, but you must provide your correct TIN. If you, at any time, become subject to backup withholding following the opening of your account(s), you agree that you will promptly notify Stifel in writing. You acknowledge and agree that the IRS does not require your consent to any provision of this Section 10(d) other than the certification required to avoid backup withholding.

## 11. Proper Instructions.

- a. **Definition. “Proper Instructions”** means instructions from you in respect of any of Stifel’s duties hereunder that have been received by Stifel at its address set forth in Section 20(f) below from an Authorized Person (as defined below) authorized by you to give the particular class of Proper Instructions in question or from a person reasonably believed by Stifel to be such an Authorized Person (i) in writing (including, without limitation, facsimile transmission, telex, or any other method whereby Stifel is able to verify with a reasonable degree of certainty the identity of the sender of such communication or the sender is required to provide a password or other identification code); (ii) by an oral communication (whether in person, by telephone, or otherwise); or (iii) upon receipt of such other form of instructions as you may from time to time authorize in writing and that Stifel agrees to accept. Instructions in the form of oral communications shall be confirmed by customer by tested telex or writing in the manner set forth in clause (i) above, but the lack of such confirmation shall in no way affect any action taken by Stifel in reliance upon such oral instructions prior to Stifel’s receipt of such confirmation, or cause Stifel to be liable for relying upon such oral communications. Proper Instructions relate to your exercise of your right and Stifel’s performance of its duties under this Safekeeping Agreement and include instructions by you for Stifel to enter into any agreement or execute any transaction on your behalf.
- b. **Form and Security Procedures.** Proper Instructions may be in writing signed by the authorized individual or individuals or may be by such other means as may be agreed to from time to time by Stifel and you. Stifel may agree to accept oral instructions, and in such case oral instructions will be considered Proper Instructions. You shall cause all oral instructions to be confirmed in writing, but your failure to do so shall not affect Stifel’s authority to rely on the oral instructions.
- c. **Authorized Persons.** Concurrently with the execution of this Safekeeping Agreement, and from time to time thereafter, as appropriate, you shall deliver to Stifel an Authorized Persons list, included on the Entity Account Resolution contained in the Safekeeping Agreement signature page. You and any agents authorized by you to act on your behalf through an access or trading authorization included on the Entity Account Resolution contained in the Safekeeping Agreement signature page accepted and approved by Stifel will be the only authorized users of the brokerage and other services under this Safekeeping Agreement. Stifel may rely on the authority of any of your Authorized Persons without further inquiry and shall be indemnified against

any liability arising from such reliance to the extent permitted by law. Notwithstanding the foregoing, each Authorized Person agrees that Stifel may, at its sole discretion: (i) require joint instruction from some or all of the Authorized Persons before taking action under this Safekeeping Agreement; and (ii) if Stifel receives instructions from any Authorized Person that are, in Stifel's opinion, in conflict with instructions received from any other Authorized Person, comply with any of these instructions and/or advise each Authorized Person of the apparent conflict and/or take no action as to any of these instructions until it receives instructions from any or all of the Authorized Persons that are satisfactory to it. Notice provided by Stifel to any Authorized Person will be deemed notice to all Authorized Persons. Each Authorized Person further agrees that it, he, or she will be jointly and severally liable for the Account with each Authorized Person. Each of the persons accepting this Agreement on your behalf represents that he or she acting alone has full power and authority to deal with Stifel on your behalf without notice to you, any other joint owner, or any other person.

**d. Ultimately Proper Instructions.** If Stifel is not provided with reasonable time to execute a Proper Instruction (including any Proper Instruction not to execute, or any other modification to, a prior Proper Instruction), Stifel will use good faith efforts to execute the Proper Instruction but will not be responsible or liable if Stifel's efforts are not successful (including any inability to change any actions that Stifel had taken pursuant to the prior Proper Instruction). The inclusion of a statement of purpose or intent (or any similar notation) in a Proper Instruction shall not impose any additional obligations on Stifel or condition or qualify its authority to effect the Proper Instruction. Stifel will not assume a duty to ensure that the stated purpose or intent is fulfilled and will have no responsibility or liability when it follows the Proper Instruction without regard to such purpose or intent.

**e. Reliance on Proper Instructions.** Stifel shall be entitled conclusively to rely and act upon Proper Instructions until Stifel has received notice of any change from you and has had a reasonable time to act thereon. Stifel may act on a Proper Instruction if it reasonably believes that it contains sufficient information and may refrain from acting on any Proper Instructions until such time that it has determined, in its sole discretion, that it has received any required clarification or authentication of Proper Instructions. Stifel may rely upon and shall be protected in acting upon any Proper Instruction or any other instruction, notice, request, consent, certificate, or other instrument or paper believed by it in good faith to be genuine and to have been properly executed by or on

behalf of you. You agree to notify Stifel at once if there is any change in the status or authorization of you or any of your Authorized Persons with authority over your Account. Until Stifel is given sufficient written advance notice to the contrary by you or a court and a reasonable amount of time to act on that notice, Stifel may continue to honor Proper Instructions by you and any agent authorized to act on behalf of your Account. If you are not a natural person, you also represent to Stifel that the use of the Safekeeping Services and the provision of instructions by one authorized person acting alone will not cause you to violate any provisions in your charter, by-laws, partnership agreement, or other constituent agreements ("Constituent Documents") or instruments or Applicable Law. Stifel shall have no liability for and you agree to reimburse, indemnify, and hold Stifel and its Affiliates and their respective partners, directors, officers, and employees and any person controlled by or controlling Stifel harmless from all Losses in connection with: (i) the use of the Safekeeping Services by you, your Authorized Persons, or any other person acting on your behalf; and (ii) any claim that the use of the Safekeeping Services or any specific transfer or transaction violates your Constituent Documents.

**12. Actions Permitted Without Express Authority.** Stifel may, in its discretion, without express authority from you (a) make payments to itself or others for minor expenses of handling securities or other financial assets relating to its duties under this Safekeeping Agreement; provided that all such payments shall be accounted for to you; (b) surrender securities or other financial assets in temporary form for securities or other financial assets in definitive form; (c) endorse for collection, in your name, checks, drafts, and other negotiable instruments; and (d) in general, attend to all non-discretionary details in connection with the sale, exchange, substitution, purchase, transfer, and other dealings with your securities and other financial assets.

**13. Records.** Stifel shall create and maintain all records relating to its activities and obligations under this Safekeeping Agreement as it is required to do so under Applicable Law. Upon reasonable notice to Stifel by you, all such records shall at all times during the regular business hours of Stifel be open for inspection by you, or your duly authorized officers, employees, or agents, and employees of the SEC for regulatory examination purposes as permitted under Applicable Law. Stifel shall, at your request, supply you with a tabulation of securities owned by you and held by Stifel and shall, when requested to do so by you and for such compensation as shall be agreed upon between you and Stifel, include certificate numbers in such tabulations as applicable. If Stifel is requested or authorized by you, or required by subpoena, administrative order, court order, or other legal process, Applicable



Law or regulation, or required in connection with any investigation, examination, or inspection of you by state or federal regulatory agencies, to produce your records or Stifel's personnel as witnesses, you agree to pay Stifel for Stifel's time and expenses, as well as the reasonable fees and expenses of Stifel's counsel, incurred in responding to such request, order, or requirement.

#### 14. Confirmations and Statements.

- a. Except as noted in Section 8 (Trading Away/Step Out Trades), Stifel shall prepare confirmations and summary periodic statements and shall, to the extent required by Applicable Law, transmit them to you in a timely fashion. You agree to provide Stifel with any additional information that may be required in connection with preparing the content of confirmations and periodic statements. You shall remain liable for compliance with the prospectus delivery requirements of the Securities Act regardless of its retention of Stifel for prospectus delivery service.
- b. You are responsible for examining all confirmations, statements, and other reports in whatever medium provided to you by us. You must notify Stifel of any error in any Account prior to settlement date or within the time in which Stifel is able to, without violating Applicable Law, cancel the transaction. Stifel shall then take reasonable remedial steps to correct such error or cancel the transaction, if possible. You waive your right to make any claim against Stifel for Losses from errors about which you do not timely notify Stifel.

#### 15. Settlement Procedures.

- a. In safekeeping the Property, Stifel shall (i) with respect to any or all of the Property, settle purchases and sales, and engage in other transactions relating to the Property, including free receipts and deliveries, exchanges, and other voluntary corporate actions, with any person, agent, financial institution, partnership, corporation, or other recipient designated by Stifel; and (ii) attend to the exchange, conversion, or surrender of Property as applicable. You understand and acknowledge that the execution, clearance, and settlement of transactions in the Property may be impacted by local market practices. Stifel will not be responsible or liable for any Losses by you, your agent(s), or Authorized Persons, or any persons claiming through these persons for any Losses that may be incurred as a result of the market practices applicable to the Property.
- b. Stifel shall not be required to comply with any Proper Instructions to settle the purchase of any securities for the Account, unless there are sufficient immediately available funds in the Account, provided that if, after all expenses, debits, and withdrawals (“Debits”)

applicable to the Account have been made and if after all Conditional Credits, as defined below, applicable to the Account have been made final entries as set forth in (d) below, the amount of immediately available funds in such Account is at least equal to the aggregate purchase price of all securities for which Stifel has received Proper Instructions to settle on that date (“Settlement Date”), Stifel, upon settlement, shall credit the Property to the Account by making a final entry on its books and records.

- c. Notwithstanding the foregoing, if after all Debits applicable to the Account have been made, there remains outstanding any Conditional Credit applicable to the Account or the amount of immediately available funds in such Account are less than the aggregate purchase price of all securities for which Stifel has received Instructions to settle on the Settlement Date, Stifel, upon settlement, may provisionally credit the Property to the Account by making a conditional entry on its books and records (“Conditional Credit”), pending receipt of sufficient immediately available funds in the Account.
- d. If, within a reasonable time after the posting of a Conditional Credit and after all Debits applicable to the Account have been made, immediately available funds at least equal to the aggregate purchase price of all securities subject to a Conditional Credit on a Settlement Date are deposited into the Account, Stifel shall make the Conditional Credit a final entry on its books and records. In such case, you shall be liable to Stifel only for late charges at a rate mutually agreed upon in writing.
- e. If (i) within a reasonable time from the posting of a Conditional Credit, immediately available funds at least equal to the resultant Debit on a Settlement Date are not on deposit in the Account, or (ii) any Proceeding (as defined below) shall occur, Stifel may sell such of the Property subject to the Conditional Credit as it selects in its sole discretion and shall apply the net proceeds of such sale to cover such Debit, including related late charges, and any remaining proceeds shall be credited to the Account. If such proceeds are insufficient to satisfy such debt in full, you shall continue to be liable to Stifel for any shortfall. Stifel shall make the Conditional Credit a final entry on its books as to the Property not required to be sold to satisfy such Debit. Pending payment in full by you of the purchase price for Property subject to a Conditional Credit, and Stifel's making a Conditional Credit a final entry on its books, you shall have no security entitlement and, unless consented to by Stifel, no right to give further Proper Instructions in respect of Property subject to a Conditional Credit. Stifel shall have the sole discretion to determine which

Property shall be deemed to have been paid for by you out of funds available in the Account. Any listing on a report to you of Property that is subject to a Conditional Credit shall be deemed for informational purposes only and such Property shall not be deemed finally credited to the Account; accordingly, such Conditional Credit may be reversed (any corresponding Debit shall be canceled) by Stifel unless and until Stifel makes a final entry on its books crediting such Property to the Account.

**“Proceeding”** shall mean any insolvency, bankruptcy, receivership, reorganization, or similar proceeding relating to you, whether voluntary or involuntary.

- f. You agree that you will not use the Account to facilitate the purchase of securities without sufficient funds in the Account (which funds shall not include the proceeds of the sale of the purchased securities).
- g. If Stifel, in its sole discretion, advances funds hereunder or there shall arise for whatever reason an overdraft in an Account (including, without limitation, overdrafts incurred with the settlement of securities transaction, funds transfers, or foreign exchange transactions) or if you are, for any other reason, indebted to Stifel, you agree to repay Stifel on demand the amount of the advance, overdraft, or indebtedness plus accrued interest at a rate ordinarily charged by Stifel to its similarly situated safekeeping customers.

#### 16. Stifel’s Standard of Care; Exculpation.

- a. **Standard of Care.** In performing its duties under this Safekeeping Agreement, Stifel shall act in good faith and shall exercise commercially reasonable care.
- b. **Other Reliance.** Stifel is authorized and instructed to rely upon the information that Stifel receives from you or any third party on behalf of you. Stifel shall have no responsibility to review, confirm, or otherwise assume any duty with respect to the accuracy or completeness of any information supplied to it by or on behalf of any third party. Stifel shall have no liability in respect of any loss, cost, or expense incurred or sustained by you arising from the performance of Stifel’s duties hereunder in reliance upon records that were maintained for you by any individual or organization, other than Stifel, prior to Stifel’s appointment as safekeeper hereunder. Stifel shall be entitled to rely on and may act upon advice of counsel (who may be counsel for you) on all matters and shall be without liability for any action reasonably taken or omitted pursuant to the advice.
- c. **No Investment Advice or Recommendations.** Stifel has no responsibility to monitor or oversee the investment activity undertaken by you or your Authorized Persons. Stifel will neither assess nor take any responsibility or liability for the suitability or appropriateness of the investments made by you or on your behalf. You

represent that you are either an Institutional Account as defined by FINRA Rule 4512(c) or any successor rule, or a sophisticated municipal market professional as defined in Municipal Securities Rulemaking Board Rule D-15. If you are a sophisticated municipal market professional, you agree to complete the Sophisticated Municipal Market Professional Certification included on the Safekeeping Agreement signature page. You further represent that you: (i) are capable of evaluating investment risks and market value independently, both in general and with regard to all transactions and investment strategies involving securities (including municipal securities), including those related to the investments you make under the terms of this Safekeeping Agreement, and (ii) will exercise independent judgment in evaluating the recommendations of any broker-dealer or municipal securities dealer in writing. You acknowledge that certain disclosure and suitability obligations under Municipal Securities Rulemaking Board rules may be deemed fulfilled in connection with municipal securities transactions by you. You represent, warrant, and acknowledge that you are not a “retail customer” for purposes of Regulation Best Interest. You acknowledge and agree to promptly notify Stifel and each broker-dealer municipal securities dealer servicing your account if any of your representations in this provision cease to be true.

- d. **Communications.** Stifel shall not be liable for any untimely exercise of any tender, exchange, or other right or power in connection with your securities or other financial assets at any time held by Stifel unless (i) Stifel is in actual possession of such financial assets, (ii) Stifel receives Proper Instructions with regard to the exercise of the right or power, and (iii) both of the conditions referred to in the foregoing clauses (i) and (ii) have been satisfied at least three (3) Business Days prior to the date on which Stifel is to take action to exercise the right or power.
- e. **Trade Counterparties.** Your receipt of securities or other financial assets from a counterparty in connection with any of its purchase transactions and its receipt of cash from a counterparty in connection with any sale or redemption of securities or other financial assets will be at your sole risk, and Stifel shall not be obligated to make demands on your behalf if your counterparty defaults. If your counterparty fails to deliver securities, other financial assets, or cash, Stifel will, as its sole responsibility, notify you of the failure within a reasonable time after Stifel became aware of the failure.

#### 17. Compensation of Stifel.

- a. **Compensation.** You agree to pay Stifel such compensation for its services pursuant to this Safekeeping Agreement as may be mutually agreed upon

in writing from time to time and Stifel's out-of-pocket or incidental expenses in connection with the performance of this Safekeeping Agreement, including (but without limitation) legal and accounting fees. The initial fee schedule is set forth in **Schedule A** attached hereto. From time to time, Stifel may change the fee schedule by providing you with a revised copy of the fee schedule. You will be deemed to accept any such change(s) to the fee schedule upon receipt unless an alternative effective date is mutually agreed upon by each party to this Safekeeping Agreement. Such fees will not be abated by, nor shall Stifel be required to account for, any profits or commissions received by Stifel in connection with its provision of safekeeping services under this Safekeeping Agreement. You agree to hold Stifel harmless from any liability or loss resulting from any taxes or other governmental charges, and any expense related thereto, which may be imposed, or assessed, with respect to any Property in your Account and also agree to hold Stifel, its sub-safekeepers, and their respective nominees harmless from any liability as a record holder of Property in your Account. Stifel is authorized to charge the Account and any other account you have with Stifel for such items. The provisions of this Section shall survive the termination of this Safekeeping Agreement.

#### **18. Disclaimer of Liability and Indemnification.**

a. **Limitation of Liability.** To the extent permitted by law, Stifel shall not be liable for any Losses by or with respect to the Account(s), except to the extent that such Losses are actual Losses proven with reasonable certainty, are not speculative, are proven to have been fairly within the contemplation of the parties as of the date hereof, and are determined by a court of competent jurisdiction or an arbitration panel in a final non-appealable judgment or order to have resulted solely from Stifel's gross negligence or willful misconduct and without limiting the generality of the foregoing, Stifel will not be liable for any indirect, special, incidental, or consequential damages or other losses (regardless of whether such damages or other losses were reasonably foreseeable). In addition, Stifel will not be liable for lost income or otherwise, if Stifel fails automatically to invest free credit balances or automatically redeem shares of a money market fund or bank deposit account in connection with the cash sweep feature described herein. In the event an action or inaction by Stifel results in an error in your Account not otherwise covered by specific error provisions in this Safekeeping Agreement, Stifel will generally seek to put you in the economic position you would have been in had the error not occurred. In such circumstances, you authorize and direct Stifel to move positions purchased or sold in error out of your Account or cash credited to you in error out of your Account in order to remedy the

error. Generally, errors resulting in de minimis losses or gains may not be corrected. Stifel's liability to you shall not exceed an amount equal to the greater of (1) \$1,000,000, or (2) the amounts paid by you to Stifel during the twelve (12) months preceding the month in which the cause of action arose (the "**Standard Liability Cap**").

b. **Indemnification.** Stifel shall have no liability for and you agree to reimburse, indemnify, and hold Stifel, its Affiliates, and their partners, directors, officers, and employees and any person controlled by or controlling Stifel (collectively, the "**Stifel Indemnified Parties**") harmless from all expenses (including legal expenses and reasonable attorneys' fees), losses or damages that arise out of, are based upon, or result from: (i) your or your agents' misrepresentation, act, or omission or alleged misrepresentation, act, or omission; (ii) Stifel's following your or your agent's directions or failing to follow your or their unlawful or unreasonable directions; (iii) any of your actions or the actions of your previous advisers or safekeeper; (iv) the failure by any person not controlled by Stifel to perform any obligations to you; and (v) in connection with any securities transaction including the sale, disposal, transfer, or pledge of securities pursuant to a registration statement or other selling document, (A) an untrue statement or alleged untrue statement of a material fact contained in any registration statement, preliminary prospectus, prospectus, pricing prospectus, or supplement, including any amendment or supplement thereto, any issuer free writing prospectus or other selling document (collectively, the "**Selling Documents**"), or (B) the omission or alleged omission to state in the Selling Documents a material fact required to be stated therein or necessary to make the statements therein not misleading. In the event that any Stifel Indemnified Party becomes involved in any capacity in any claim, action, proceeding, or investigation brought by or against any person in connection with any matter arising out of or in connection with this Agreement or your Account (including a breach of this Agreement by you), you agree to periodically (but no less than on a quarterly basis) advance funds to (or reimburse) such Stifel Indemnified Party for the legal and other expenses (including the cost of any investigation and preparation) it expects to incur (or has incurred) in connection therewith, provided that such Stifel Indemnified Party will promptly repay to you the amount of any such advanced or reimbursed expenses paid to it if it will ultimately be determined by a court having appropriate jurisdiction in a decision that is not subject to appeal that such Stifel Indemnified Party is not entitled to be indemnified by you in connection with such action, proceeding, or investigation.

c. **Third Party Actions.** Stifel shall be without responsibility or liability to you for: (i) errors by you or any Authorized Person in their instructions to Stifel; (ii) the insolvency of or acts or omissions by a United States Securities System or domestic sub-safekeeper designated pursuant to Section 3(b); (iii) the failure of you or any duly authorized individual or organization to adhere to Stifel's operational policies and procedures; (iv) any delay or failure of any broker, agent, securities intermediary or other intermediary, central bank, or other commercially prevalent payment or clearing system to deliver to Stifel's sub-safekeeper or agent securities or other financial assets purchased or in the remittance or payment made in connection with securities or other financial assets sold; (v) any delay or failure of any organization in charge of registering or transferring securities or other financial assets in the name of Stifel, you, Stifel's sub-safekeepers, nominees, or agents, including non-receipt of bonus, dividends, and rights and other accretions or benefits; (vi) delays or inability to perform its duties due to any disorder in market infrastructure with respect to any particular security, other financial asset, or United States Securities System; and (vii) the effect of any provision of any law or regulation or order of the United States of America, or any state thereof, or any other country, or political subdivision thereof, or of any court of competent jurisdiction.

d. **Indirect/Special/Consequential Damages.** In no event shall Stifel be liable for any special, indirect, incidental, punitive, or consequential damages of any kind whatsoever with respect to the services provided in respect of this Safekeeping Agreement, including, but not limited to, any loss of use, loss of data, trading losses, business interruption, or loss of income or profits or other economic losses, whether or not foreseeable and regardless of whether Stifel or Stifel's Affiliates had advance notice of the possibility of any such damages, and regardless of the form of claim, whether in contract, negligence, strict liability, or other liability or other legal or equitable theory.

e. **Force Majeure.** Neither party shall incur any liability due to failure or delay in performance of any obligation caused by Force Majeure, at least for the duration of the Force Majeure; provided, however, that the affected party shall promptly notify the other of the existence of the Force Majeure and the effect on its ability to perform its obligations, and that the affected party undertakes all reasonable efforts to mitigate the impact of the Force Majeure on the other party. The term "**Force Majeure**" shall mean and include any act of God, industry-wide strikes, explosion, fire, flood, war and other hostilities, civil commotion, governmental acts, regulations or

orders, generalized inadequate supply of raw materials or components, or any other circumstance of a similar nature beyond the reasonable control of an affected party (but excluding any act or omission by an Affiliate of such party). If any Force Majeure endures more than thirty (30) days, the parties shall meet and review in good faith the desirability and conditions of this Safekeeping Agreement, and Stifel may determine to terminate without further liability to you. Stifel shall have the right to cover and seek a third-party source for services, at its own expense, during any event of Force Majeure, without liability to you for any services affected by the Force Majeure. You shall not be entitled to claim relief under this Section to the extent the effect of the Force Majeure event could have been avoided or mitigated by reasonably prudent measures or the proper performance of any disaster recovery or business continuity obligations hereunder.

f. **Market Data Disclaimer.** Stifel may display or otherwise make available or accessible to you in connection with the services contemplated by this Safekeeping Agreement, certain information, including, without limitation, financial news, reports, analyses, quotes, and trade-securities and investment-related data, news, research, and other market or pricing information (collectively, "**Market Data**"). All Market Data is provided "as is" and "as available," and there may be unavailability, delays, omissions, and inaccuracies in Market Data. Neither Stifel nor its Affiliates, market data provider(s), or service providers or anyone else involved in creating, producing, delivering or managing the delivery of such Market Data, information, or services are authorized to guarantee, nor does Stifel or its Affiliates guarantee the correctness, quality, accuracy, sequence, timeliness, currentness, reliability, performance, completeness, continued availability, merchantability, fitness for a particular purpose, title, or non-infringement or otherwise of any Market Data. Stifel hereby disclaims any such express or implied warranties. Stifel also reserves the right to filter any Market Data provided or otherwise made available to you.

## 19. Effective Period and Termination.

a. **Termination.** This Safekeeping Agreement shall remain in effect until Stifel receives (1) a written statement from you that you wish to terminate your Account(s), and (2) instructions required by Section 4(c) of this Safekeeping Agreement, after which time you will not be bound for any further transactions made for your Account(s). However, you shall remain liable for all prior transactions in your Account(s). You will remain liable for any charges arising in your Account(s), whether arising before or after termination. Stifel reserves the right to terminate your account at any time by ninety (90) days' written notice to you.

- b. **Payments Owing to Stifel.** Upon termination of this Safekeeping Agreement pursuant to Section 19(a), you shall pay to Stifel any compensation then due and shall reimburse Stifel for its other fees, expenses, and charges. In the event of (i) your termination of this Safekeeping Agreement for any reason other than as set forth in Section 16(a) or (ii) a transaction not in the ordinary course of business pursuant to which Stifel is not retained to continue providing services hereunder to you (or your successor), you shall pay to Stifel any compensation due through and shall reimburse Stifel for its other fees, expenses, and charges. Upon receipt of such payment and reimbursement, Stifel will deliver your securities and other financial assets as set forth in Section 4(c).
- c. **Effect of Termination.** Following termination, Stifel shall have no further obligations to you with respect to this Safekeeping Agreement. The provisions of Sections 17, 18(a), 18(b), 18(d), 20(a), 20(k), 20(l), 23, and 24 of this Safekeeping Agreement shall survive termination of this Safekeeping Agreement.
- d. **Remaining Property.** If any of your Property held by Stifel hereunder remains held by Stifel after the termination of this Safekeeping Agreement owing to your failure to provide Proper Instructions or otherwise, Stifel shall be entitled to fair compensation for its services during such period as Stifel holds the securities or other financial assets in an amount not less than the compensation to which Stifel would have been entitled had there been no termination. If, after ninety (90) days of the termination of this Safekeeping Agreement, any of your Property is still held by Stifel, Stifel may, at its sole discretion, liquidate such Property. The provisions of this Safekeeping Agreement relating to the duties, exculpation, and indemnification of Stifel shall apply in favor of Stifel during such period.

## 20. General.

- a. **Governing Law; Exclusive Forum.** Any and all matters in dispute between the parties hereto, whether arising from or relating to this Safekeeping Agreement, shall be governed by and construed in accordance with laws of the State of Missouri, without giving effect to any conflict of laws rules that would require the application of the law of any other jurisdiction. If there is a lawsuit arising out of a dispute under this Safekeeping Agreement, the lawsuit must be brought in a federal court in or a state court of the State of Missouri.
- b. **Prior Agreements.** This Safekeeping Agreement supersedes all prior agreements between you and Stifel relating to the safekeeping of your assets.
- c. **Amendments.** You agree that Stifel shall have the right to amend this Safekeeping Agreement by modifying or

rescinding any of its existing provisions or by adding any new provision, at any time, by posting or linking the amendment on or through the electronic means you have agreed to in any current or subsequent Safekeeping Service Documentation and by sending a notice of the amendment to you. An amendment shall be effective as of the date established by Stifel. The change will automatically become effective unless, prior to the effective date, you notify Stifel of your intention to terminate this Safekeeping Agreement. Stifel reserves the right to make emergency changes for security reasons, without prior written notice to you. You understand that additional restrictions may apply to the Safekeeping Agreement provided hereunder and additional documentation may be required by Applicable Law or Stifel policies and procedures. You agree to promptly comply with any such restrictions and requests for additional documents.

- d. **Assignment.** This Safekeeping Agreement may not be assigned by either party without the consent of the other. However, without your consent, Stifel may (i) delegate any of its duties under this Safekeeping Agreement to an Affiliate or other person so long as Stifel remains responsible if the duty is not performed or (ii) assign this Safekeeping Agreement to a successor of all or a substantial portion of its business, or to a party controlling, controlled by, or under common control with Stifel.

### e. The Parties; Representations and Warranties.

- i. *Your Representations and Warranties.* As applicable, you hereby represent and warrant that (A) you are duly organized and validly existing in good standing in your jurisdiction of organization; (B) you have and will have at all relevant times the requisite power and authority under Applicable Law and your organizational documents to enter into and perform under this Safekeeping Agreement and to carry on your business; (C) all requisite proceedings have been taken to authorize you to enter into and perform this Safekeeping Agreement; (D) no legal or administrative proceedings have been instituted or threatened that would materially impair your ability to perform your duties and obligations under this Safekeeping Agreement; (E) your entering into or performance of this Safekeeping Agreement shall not at any relevant time cause a material breach or be in material conflict with any other agreement or obligation you have or any law or regulation applicable to you; and (F) you are appropriately registered or exempt or excluded from registration with applicable federal, state, or foreign regulatory authority.

ii. *Stifel Representations and Warranties.* Stifel hereby represents and warrants that (A) it is organized and existing under the laws of the State of Missouri and is registered as a broker-dealer with the SEC and a member of FINRA; (B) it has and will have at all relevant times the requisite power and authority to carry on its business in the State of Missouri; (C) all requisite proceedings have been taken to authorize it to enter into and perform this Safekeeping Agreement; (D) no legal or administrative proceedings have been instituted or threatened which would materially impair Stifel's ability to perform its duties and obligations under this Safekeeping Agreement; and (E) its entering into or performance of this Safekeeping Agreement shall not at any relevant time cause a material breach or be in material conflict with any other agreement or obligation of Stifel or any law or regulation applicable to it.

f. **Notices.** Any notice, instruction, or other communication required to be given hereunder will, unless otherwise provided in this Safekeeping Agreement, be in writing and may be sent by hand, or by facsimile transmission, or overnight delivery by any recognized delivery service, to you at the address you provide in the Account Instructions Supplement and to Stifel at the below address. These addresses may be modified only upon notification by the changing party to the other party.

To Stifel: Operations Director – New Accounts  
501 North Broadway  
St. Louis, Missouri 63102

Notices shall be deemed effective when received, or, in the case of a facsimile, when sent to the proper number and acknowledged by a proper response.

g. **Counterparts.** This Safekeeping Agreement may be executed in several counterparts, each of which shall be deemed to be an original, and all such counterparts taken together shall constitute one and the same Safekeeping Agreement. Counterparts may be executed in either original or electronically transmitted form (e.g., faxes or e-mailed portable document format (PDF) form), and the parties hereby adopt as original any signatures received in electronically transmitted form.

h. **Severability; No Waiver.** If any provision of this Safekeeping Agreement shall be held to be invalid, unlawful, or unenforceable, the validity, legality, and enforceability of the remaining provisions shall not in any way be affected or impaired. The failure of a party hereto to insist upon strict adherence to any term of this Safekeeping Agreement on any occasion or the failure of a party hereto to exercise or any delay in exercising any

right or remedy under this Safekeeping Agreement shall not constitute a waiver of any term, right, or remedy or a waiver of any other rights or remedies, and no single or partial exercise of any right or remedy under this Safekeeping Agreement shall prevent any further exercise of the right or remedy or the exercise of any other right or remedy.

i. **Public Statements.** You and Stifel shall consult with one another before issuing any written or oral statement and give each other the opportunity to review and comment upon any press release, advertisement, promotional materials, or other public statements, other than with regard to the relationship between the parties ("Public Statements"), with respect to this Safekeeping Agreement, or any of the transactions contemplated in this Safekeeping Agreement, and shall not issue any Public Statement without the consent of the party that is not seeking to make the Public Statement, except as may be required by Applicable Law, governmental order, or any regulatory or judicial authority with jurisdiction over the person seeking to make the Public Statement, provided, however, that the party making the Public Statement shall provide the party not making the Public Statement with advance notice of the content of such Public Statement as permitted by Applicable Law.

j. **Use of Names/Logos/Marks.** Except as otherwise expressly provided in this Safekeeping Agreement, no party to this Safekeeping Agreement shall use the other party's proprietary indicia, trademarks, service marks, trade names, logos, symbols, or brand names, or otherwise refer to or identify the other party ("Identifying Marks") in any advertising, publicity releases, or promotional or marketing publications without, in each case, securing the prior written consent of the other party, except as may be required by Applicable Law with jurisdiction over the party seeking to use the Identifying Marks, provided, however, that the party seeking to use the Identifying Marks shall provide the party who owns the Identifying Marks with advance notice of the content of such Public Statement as permitted by Applicable Law.

k. **Confidentiality.**

i. *General.* You acknowledge that you or an Authorized Person may be exposed to or acquire Confidential Information in connection with this Safekeeping Agreement. The term "Confidential Information," as used in this Section 20(k), means any non-public information or data provided by or on behalf of Stifel or its Affiliates to you or an Authorized Person in connection with this Safekeeping Agreement, or to which you or an Authorized Person has or obtains access, whether

- or not marked as confidential, and any information, analyses, or data developed or derived therefrom, including, without limitation, (i) information that concerns the management, business, affairs, relationships, pricing, or financials of Stifel or its clients; (ii) proprietary files maintained by Stifel; (iii) the internal policies and procedures applicable to Stifel's employees and contingent personnel and the formulation of investment strategies and policies; (iv) product or service displays, designs, descriptions, procedures, formulas, discoveries, inventions, specifications, drawings, sketches, models, samples, computer programs, algorithms, codes, improvements, and concepts; (v) information related to past, present, and future research, development, business activities, products, or services that are proprietary to Stifel or to a third party to whom Stifel or any of its Affiliates owes a duty of confidentiality; (vi) any additional information Stifel may designate as Confidential Information either orally or in writing; and (vii) any copies of the foregoing.
- ii. *Exclusions.* Notwithstanding Section 20(k)(i), Confidential Information shall not include information that (i) is or becomes publicly available other than by disclosure by you or an Authorized Person in violation of this Safekeeping Agreement or by the wrongful conduct of others; (ii) was known to you or an Authorized Person prior to its receipt hereunder; (iii) is independently developed by you or an Authorized Person without use of, reference to, or reliance on the Confidential Information; or (iv) was rightfully obtained by you or an Authorized Person from a third party that does not have a duty of confidentiality or a restriction on use concerning such information.
- iii. *Limitations on Use.* You and your Authorized Persons shall not use the Confidential Information for any purpose other than for those activities contemplated under this Safekeeping Agreement. You and your Authorized Persons shall hold the Confidential Information in strict confidence, shall not copy, reproduce, sell, assign, license, market, transfer, or otherwise dispose of, give, or disclose Confidential Information to any person, firm, or corporation, or permit any agent or employee to do the same. You and your Authorized Persons may disclose Confidential Information only to those personnel who have a need to know such Confidential Information in connection with this Safekeeping Agreement and who are bound by appropriate non-disclosure obligations that are at least as protective of Stifel's information as the obligations under this Safekeeping Agreement and that satisfy the requirements of the Defend Trade Secrets Act of 2016, 18 U.S.C. § 1833. You and your Authorized Persons shall use at least the same degree of care in handling the Confidential Information as you use with regard to your own proprietary information of a similar nature, but in no event less than a reasonable standard of care.
- iv. *Acknowledgment by You.* You acknowledge that Stifel's Confidential Information is deemed the exclusive property of Stifel. Stifel's disclosure of the Confidential Information does not constitute an express or implied grant to you or your Authorized Persons of any rights to or under Stifel's patents, patent applications, copyrights, trade secrets, trademarks, or other intellectual property rights.
- v. *Termination.* Upon termination or expiration of this Safekeeping Agreement, or at any time upon the written request of Stifel, you shall, at its cost, promptly (i) return the Confidential Information to Stifel, (ii) destroy or permanently erase (on all forms of physical and electronic media) the Confidential Information that cannot be returned, and (iii) upon Stifel's request, provide Stifel a certificate in form and substance satisfactory to Stifel, stating that the requirements of this Section have been met.
- vi. *Requests for Disclosure.* In the event that you or an Authorized Person receives a request, or is required, to disclose any Confidential Information under a subpoena, court order, statute, law, rule, regulation, or inquiry issued by a court of competent jurisdiction or by a judicial or administrative agency, legislative body or committee, or self-regulatory organization (each a "Legal Request"), you shall promptly notify Stifel in writing, as permitted by law, so that Stifel may seek to avoid or minimize the Legal Request or obtain an appropriate protective order or other relief, or, in the discretion of Stifel, to waive compliance with the provisions of this Section. If so requested, you and your Authorized Persons shall reasonably cooperate in the defense against any Legal Request. If Stifel is unable to obtain or does not seek a protective order and you are legally required to disclose such Confidential Information, you will disclose only that portion of the requested Confidential Information that you are required to disclose.
- vii. *Breach.* The parties acknowledge that the transactions contemplated hereby are unique and a breach by you or an Authorized Person of this Section will result in irreparable injury to Stifel for which monetary damages alone would not be an adequate remedy. If there is a breach or threatened

breach of this Section, Stifel shall be entitled to specific performance and injunctive or other equitable relief as a remedy for any such breach or anticipated breach without the necessity of posting a bond. Any such relief shall be in addition to and not in lieu of any appropriate relief in the way of monetary damages.

**l. Use of Data.** In the course of providing services, Stifel may receive information and data (“**Data**”) with respect to your assets held in safekeeping by Stifel, transactions and other activities with respect to your assets or accounts (whether executed with Stifel or by a third party), and assets underlying instruments held by you. Stifel may use Data (i) whether as sub-safekeeper or otherwise, in the provision of services to you, (ii) in risk management, research, and other products that Stifel offers to third parties, as to which Stifel may receive compensation, and (iii) in the management of Stifel’s own business. Stifel agrees that, without your consent, Stifel may not sell, license, or otherwise distribute to any person any Data that identifies you other than where disclosure is required as provided in Section 21(k)(iii). Stifel shall have exclusive ownership and use of any intellectual property rights in any derivative Data and shall have independent ownership rights in any Data as to which it is a party to the underlying transaction or instrument.

**m. Data Privacy.** Stifel will take appropriate security measures to safeguard “nonpublic personal information,” as defined in Title V of the Gramm-Leach-Bliley Act of 1999 or any successor federal statute, and any rules and regulations thereunder, all as may be amended or supplemented from time to time, that relates to your shareholders, employees, directors, and officers that Stifel receives, stores, maintains, processes, or otherwise accesses in connection with the provision of services hereunder.

**n. Independent Contractor.** You are, and shall be at all times, an independent contractor hereunder and not an agent of Stifel; and nothing contained in this Safekeeping Agreement nor any actions taken by or arrangements entered into between them in accordance with the provisions of this Safekeeping Agreement shall be construed as or deemed to create any partnership or joint venture between the parties. You shall have no authority to commit Stifel contractually or otherwise to any obligations to third parties.

**o. Asset Protection.** Your Securities Account is protected by SIPC in accordance with the terms of SIPC. SIPC is a non-profit membership corporation created by the Securities Investor Protection Act of 1970, funded primarily by its member securities brokerage firms

registered with the U.S. Securities and Exchange Commission. SIPC provides clients of securities brokerage firms that are members of SIPC, such as Stifel, with protection against custodial risk in the event such firms become insolvent.

Unlike Federal Deposit Insurance Corporation (“**FDIC**”) insurance, SIPC does not insure against the loss of your investment. SIPC coverage does not ensure the quality of investments, protect against a decline or fluctuations in the value of your investment, or cover securities not held by Stifel. SIPC protects each client’s securities and cash held in a client’s brokerage account at an insolvent brokerage firm. SIPC coverage protects securities customers of its members up to \$500,000 (including \$250,000 for claims for cash). Stifel has purchased additional securities coverage of \$149,500,000 and cash coverage of \$900,000. Thus, with Stifel’s coverage combined with SIPC coverage, clients receive a total of \$150,000,000 of securities coverage and \$1,150,000 of cash coverage, subject to the terms and conditions of Stifel’s policy, with an aggregate limit of \$300,000,000. (For more information, including more up to date information about asset protection, visit [www.stifel.com](http://www.stifel.com): “Important Disclosures,” “Asset Protection.”)

If you have questions about SIPC coverage and additional securities coverage, please contact the Stifel representative with whom you regularly interact regarding your Account. You may also obtain information about SIPC coverage, including a brochure that describes SIPC and SIPC coverage, by accessing the SIPC website at [www.sipc.org](http://www.sipc.org) or contacting SIPC at (202) 371-8300

## 21. U.S. Special Resolution Regimes and Insolvency Proceedings.

**a. General.** The provisions of this Section apply in certain circumstances in which Stifel and/or its affiliates could become subject to (i) a proceeding under a U.S. Special Resolution Regime or (ii) an Insolvency Proceeding. For purposes of this section, “**Stifel Entity**” means Stifel or any of its “affiliates,” as that term is defined in, and interpreted under, 12 U.S.C. § 1841(k); “**Stifel Party**” means a Stifel Entity that is a party to this Agreement; “**Stifel Affiliate**” means any “affiliate” of a Stifel Party, as the term “affiliate” is defined in, and interpreted under, 12 U.S.C. § 1841(k); “**U.S. Special Resolution Regime**” means each of (x) the Federal Deposit Insurance Act and the regulations promulgated thereunder and (y) Title II of the Dodd-Frank Wall Street Reform and Consumer Protection Act and the regulations promulgated thereunder; “**Insolvency Proceeding**” means a receivership, insolvency, liquidation, resolution, or similar proceeding; “**Default Right**” has the meaning



assigned to that term in, and shall be interpreted in accordance with, 12 C.F.R. § 252.81, 12 C.F.R. § 47.2, or 12 C.F.R. § 382.1, as applicable, which meaning may include, without limitation, any right to liquidate, terminate, cancel, rescind, or accelerate; set off or net amounts owing; exercise remedies in respect of collateral or other credit support; demand payment or delivery; suspend, delay, or defer payment or performance; modify obligations; alter the amount of collateral or margin provided; demand the return of any collateral or margin; or modify any right to reuse collateral or margin; **“Credit Enhancement”** means any guarantee, collateral arrangement, or any other credit enhancement or credit support arrangement in support of the obligations of a Stifel Party to any other party or the obligations of another party to a Stifel Party under this Agreement or any transaction hereunder or contemplated hereby (including without limitation any pledge, charge, mortgage, or other security interest or title transfer collateral arrangement, trust or similar arrangement, letter of credit, transfer of margin, or any similar arrangement); **“Stifel Affiliate Credit Enhancement”** means any Credit Enhancement provided by a Stifel Affiliate that supports the obligations of a Stifel Party; **“Relevant Transferee”** means, with respect to a Stifel Affiliate Credit Enhancement, a person to whom such Stifel Affiliate Credit Enhancement is transferred upon the Stifel Affiliate that provided such Credit Enhancement entering Insolvency Proceedings or thereafter as part of the resolution, restructuring, or reorganization involving such Stifel Affiliate; and **“Relevant Agreement”** means this Agreement, each transaction under this Agreement that is a “qualified financial contact,” as such term is defined in, and interpreted under, 12 U.S.C. § 5390(c)(8)(D) and each Credit Enhancement related thereto.

**b. Recognition of U.S. Special Resolution Regimes.**

- i. In the event that any Stifel Party becomes subject to a proceeding under a U.S. Special Resolution Regime, the transfer from the Stifel Party of this Agreement and any other Relevant Agreement, and any interest and obligation in or under, and any property securing, this Agreement and any other Relevant Agreement, will be effective to the same extent as the transfer would be effective under the U.S. Special Resolution Regime if this Agreement and such Relevant Agreement, and any interest and obligation in or under, and any property securing, this Agreement and such Relevant Agreement, were governed by the laws of the United States or a state of the United States.
- ii. In the event that a Stifel Party or any Stifel Affiliate becomes subject to a proceeding under a U.S.

Special Resolution Regime, Default Rights with respect to this Agreement and such Relevant Agreement that may be exercised against the Stifel Party are permitted to be exercised to no greater extent than such Default Rights could be exercised under the U.S. Special Resolution Regime if this Agreement and such Relevant Agreement were governed by the laws of the United States or a state of the United States. The requirements of this paragraph (b) apply notwithstanding the following paragraph (c).

**c. Limitation on the Exercise of Certain Rights Related to Affiliate Insolvency Proceedings.** Notwithstanding anything to the contrary in this Agreement or any other agreement, except the requirements of paragraph (b) as noted above,

- i. No party to this Agreement or any other Relevant Agreement shall be permitted to exercise any Default Right against a Stifel Party with respect to this Agreement or any other Relevant Agreement that is related, directly or indirectly, to a Stifel Affiliate becoming subject to Insolvency Proceedings, except to the extent the exercise of such Default Right would be permitted under the creditor protection provisions of 12 C.F.R. § 252.84, 12 C.F.R. § 47.5, or 12 C.F.R. § 382.4, as applicable; and
- ii. Nothing in this Agreement or any other Relevant Agreement shall prohibit the transfer of any Stifel Affiliate Credit Enhancement, any interest or obligation in or under such Stifel Affiliate Credit Enhancement, or any property securing such Stifel Affiliate Credit Enhancement to a Relevant Transferee upon or following a Stifel Affiliate becoming subject to Insolvency Proceedings, unless the transfer would result in the party supported thereby being the beneficiary of such Credit Enhancement in violation of any law applicable to such party. After a Stifel Affiliate has become subject to Insolvency Proceedings, if any party other than a Stifel Party seeks to exercise any Default Right with respect to this Agreement or any other Relevant Agreement, such party shall have the burden of proof, by clear and convincing evidence, that the exercise of such Default Right is permitted hereunder.

**22. Affirmative Tax Consent.** By signing below, you represent that you are and will remain in compliance with the applicable tax, legal, and other financial disclosure obligations to which you are subject. You also affirm that, to the best of your knowledge (i) the existence of the account and the assets in the account have been or

will be disclosed, as may be required by the laws of your country of citizenship and your country(ies) of residence (if different), and by any other country's laws that might apply to you or your assets, and (ii) any asset transfers into or out of the account were and will be in full compliance with the laws of your country of citizenship and your country(ies) of residence (if different), and with any other country's laws that might apply to you or your assets.

### 23. Arbitration.

**General.** This Agreement contains a predispute arbitration agreement. By signing an arbitration agreement, the parties agree as follows:

- a. All parties to this Agreement are giving up the right to sue each other in court, including the right to a trial by jury, except as provided by the rules of the arbitration forum in which a claim is filed.
- b. Arbitration awards are generally final and binding; a party's ability to have a court reverse or modify an arbitration award is very limited.
- c. The ability of the parties to obtain documents, witness statements, and other discovery is generally more limited in arbitration than in court proceedings.
- d. The arbitrators do not have to explain the reason(s) for their award unless, in an eligible case, a joint request for an explained decision has been submitted by all parties to the panel at least 20 days prior to the first scheduled hearing date.
- e. The panel of arbitrators may include a minority of arbitrators who were or are affiliated with the securities industry.
- f. The rules of some arbitration forums may impose time limits for bringing a claim in arbitration. In some cases, a claim that is ineligible for arbitration may be brought in court.
- g. The rules of the arbitration forum in which the claim is filed, and any amendments thereto, are incorporated into this Agreement.

**Disputes Subject to Arbitration.** Stifel and you (for yourself and on behalf of your principals, agents, beneficiaries, successors, heirs, and assigns) agree that all claims, controversies, and disputes between you and Stifel, Stifel's agents, employees, officers, and directors, any entity affiliated with Stifel that is a FINRA member firm, and/or any clearing agent of Stifel (collectively "Disputes") shall be resolved by binding arbitration before FINRA Dispute Resolution.

Stifel and you agree that all Disputes shall be arbitrated whether the Disputes arose prior to, on, or subsequent to the date hereof. Stifel and you

further agree that Disputes includes, but is not limited to, claims, controversies, and disputes concerning, relating to, or arising from:

- i. Any account maintained by you at any time with Stifel, any entity affiliated with Stifel that is a FINRA member firm, or any clearing agent of Stifel, whether maintained by you individually and for your own benefit, jointly with any other person or entity, or in any representative capacity, including, but not limited to, as a trustee or guardian;
- ii. Any account in which you claim a beneficial interest maintained by any person other than you with Stifel, any entity affiliated with Stifel that is a FINRA member firm, or any clearing agent of Stifel;
- iii. Any transaction involving Stifel or any predecessor or successor firms by merger, acquisition, or other business combination and you, whether you acted individually, jointly with another person, or in a representative capacity and whether or not such transaction occurred in an account referenced in (i) or (ii) above;
- iv. Any recommendation of any securities transaction or investment strategy involving securities, including a recommendation of a type of account, made by Stifel or any predecessor or successor firms by merger, acquisition, or other business combination to you, whether or not the recommendation resulted in a securities transaction in an account referenced in (i) or (ii) above;
- v. The construction, performance, or breach of this Agreement or any other agreement between you and Stifel, any entity affiliated with Stifel that is a FINRA member firm, and/or any clearing agent of Stifel; or
- vi. The business activities of Stifel, an associated person of Stifel, any entity affiliated with Stifel that is a FINRA member firm, and/or any clearing agent of Stifel.

Stifel and you agree that any issue concerning the validity, enforceability, or scope of the arbitration agreement, including the arbitrability of a particular claim, controversy, or dispute, shall be resolved by binding arbitration before FINRA Dispute Resolution.

**The Arbitration Forum.** Any and all Disputes shall be submitted exclusively to FINRA Dispute Resolution and administered under the then current FINRA Code of Arbitration Procedure for Customer Disputes and other applicable FINRA rules, as amended from time to time (collectively, the "FINRA Code of Arbitration Procedure").

Arbitration Hearing Locale. The hearing location for any arbitration of any Dispute in accordance with this Agreement shall be determined by the FINRA Director of Dispute Resolution in accordance with the FINRA Code of Arbitration Procedure.

Enforcement of This Arbitration Agreement. This arbitration agreement shall be enforced and interpreted exclusively in accordance with applicable federal laws of the United States, including the Federal Arbitration Act.

If you file any Disputes in court, Stifel may seek to compel arbitration of the Disputes, and you agree not to oppose any efforts to compel arbitration of such Disputes.

Judgment confirming any arbitration award in any arbitration conducted in accordance with this Agreement may be entered in any court having jurisdiction.

This arbitration agreement shall survive the termination of this Agreement.

Class Actions. No person shall bring a putative or certified class action to arbitration. No person shall seek to enforce any predispute arbitration agreement against any person who has initiated in court a putative class action; or who is a member of a putative class who has not opted out of the class with respect to any claims encompassed by the putative class action until: (i) the class certification is denied; or (ii) the class is decertified; or (iii) the customer is excluded from the class by the court. Such forbearance to enforce an agreement to arbitrate shall not constitute a waiver of any rights under this Agreement except to the extent stated herein.

A copy of this arbitration agreement is hereby given to you, and you acknowledge receipt thereof by signing the Signature Document and/or Agreement Confirmation provided to you.

24. **Waiver of Rights to Trial by Jury.** In the unlikely event any controversy or dispute between you and Stifel is determined to be ineligible for arbitration or not required to be arbitrated, you agree as follows: **THE PARTIES TO THIS AGREEMENT SHALL NOT EXERCISE ANY RIGHTS THEY MAY HAVE TO ELECT OR DEMAND A TRIAL BY JURY. YOU AND STIFEL HEREBY EXPRESSLY WAIVE ANY RIGHT TO A TRIAL BY JURY.** You acknowledge and agree that this provision is a specific and material aspect of the agreement between the parties and that Stifel would not enter into this Agreement with you if this provision were not part of the agreement.
25. **Forum Selection Clause.** Without limiting in any respect the arbitration agreement in Section 23 of this Agreement

and your agreement and obligation to arbitrate all Disputes, any suit, claim, or action filed against Stifel or its present or past parents, subsidiaries, affiliates, officers, agents, or employees in court shall be brought and heard only in the State of Missouri in St. Louis County Circuit Court. Entering into the Agreement constitutes your consent to submit to the personal jurisdiction of the courts of the State of Missouri. You hereby waive any objection based on forum non conveniens and any objection to venue in relation to any such any action.

This paragraph shall apply even if you have related disputes with other parties that cannot be resolved in the same locale.

SAFEKEEPING AGREEMENT SIGNATURE DOCUMENT

IN WITNESS WHEREOF, you have caused this Safekeeping Agreement to be executed in its name and behalf by your duly authorized representative as of the date first above-written.

You further acknowledge that you have received and read, and understand and agree to the terms and conditions contained herein as well as the following. Please complete and return the following six pages of the Safekeeping Agreement signature document to Stifel

Entity Account Resolution

- 501(c)(3) Non-Profit Corporation                       C Corporation                       Government Entity
- 501(c)(3) Non-Profit Unincorporated                       S Corporation                       Other: \_\_\_\_\_

To Stifel, Nicolaus & Company, Incorporated ("Stifel")

The undersigned corporation, association, or unincorporated entity ("Entity"), Port of Hood River,  
*(Entity)*

by its President, Chairperson, Director, or other Authorized Officer, Ben Sheppard, Commission President,  
*(Name and Title)*

pursuant to the resolutions set forth below, certified by the President, Chairperson, Director, or other Authorized Officer, hereby authorizes you to open an account in the name of said Entity; and the undersigned represents that no one other than the undersigned has any interest in such account.

I further certify that by placing my initials here \_\_\_\_\_, I am also one of the individuals authorized to act on behalf of the Entity named herein.

This authorization shall continue in force until revoked by the undersigned Entity by a written notice, addressed to you and delivered at your office at the address shown on the reverse.

I further certify that each of the following authorized individual(s) has been authorized to act on behalf of the Entity named herein:

<u>Kevin Greenwood, Executive Director</u>	
<i>(Name and Title)</i>	<i>(Signature)</i>
<u>Debbie Smith-Wagar, Finance Director</u>	
<i>(Name and Title)</i>	<i>(Signature)</i>
<u> </u>	
<i>(Name and Title)</i>	<i>(Signature)</i>
<u> </u>	
<i>(Name and Title)</i>	<i>(Signature)</i>

CERTIFIED COPY OF CERTAIN RESOLUTIONS ADOPTED BY THE BOARD OF DIRECTORS  
WHEREBY THE ESTABLISHMENT AND MAINTENANCE OF SECURITY ACCOUNTS HAVE BEEN AUTHORIZED

**RESOLVED**

**FIRST:** That the above-named Authorized Individual(s) of this Entity, whether acting individually or collectively, are hereby authorized and empowered, for and on behalf of this Entity, to establish and maintain one or more accounts with Stifel, Nicolaus & Company, Incorporated ("Stifel") for the purpose of purchasing, investing in, or otherwise acquiring, selling, possessing, transferring, exchanging, pledging, or otherwise disposing of, or turning to account of, or realizing upon, and generally dealing in and with any and all forms of securities, including, without limitation, shares, stocks, bonds, debentures, notes, scrip, participation certificates, rights to subscribe, option warrants, options, certificates of deposit, mortgages, choses in action, evidences of indebtedness, commercial paper, certificates of indebtedness, and certificates of interest of any and every kind and nature, whatsoever, secured or unsecured, whether represented by trust, participating and/or other certificates or otherwise, and any and all commodities and/or contracts for the future delivery thereof, whether represented by trust, participating and/or other certificates or otherwise, and to withdraw monies and/or wire funds.

The fullest authority at all times with respect to any such commitment or with respect to any transaction deemed by any of the Authorized Individual(s) and/or agents of the Entity to be proper in connection therewith is hereby conferred, including authority (without limiting the generality of the foregoing) to give written or oral instructions to Stifel with respect to said transactions; to bind and obligate the Entity to and for the carrying out of any contract, arrangement, or transaction, which shall be entered into by any of the Authorized Individual(s) and/or agents of the Entity with or through Stifel; to order the transfer or delivery thereof to any other person, whatsoever, and/or to order the transfer of record of any securities to any name selected by any of the Authorized Individual(s) or agents of the Entity; to affix the Entity seal to any documents or agreements, or otherwise; to endorse any securities in order to pass title thereto; to direct the sale or exercise of any rights with respect to any securities; to sign for the Entity all releases, powers of attorney, and/or other documents in connection with any such account, and to agree to any terms or conditions to control any such account; to direct Stifel to surrender any securities to the proper agent or party for the purpose of effecting any exchange or conversion, or for the purpose of deposit with any protective or similar committee, or otherwise; to accept delivery of any securities; to appoint any other person or persons to do any and all things that any of the Authorized Individual(s) and/or agents of the Entity are hereby empowered to do, and take all action necessary in connection with the account, or considered desirable by the Authorized Individual(s) and/or agents of the Entity with respect thereto.

**SECOND:** That Stifel may deal with any and all of the Authorized Individual(s) and/or agents of the Entity directly or indirectly empowered by the foregoing resolution, as though they were dealing with the Entity directly.

**THIRD:** That the President, Chairperson, Director, or Other Authorized Officer of the Entity is hereby authorized, empowered, and directed to certify to Stifel:

- a) A true copy of these resolutions;
- b) Specimen signatures of each and every person by these resolutions empowered; and
- c) A certificate (which, if required by Stifel, shall be supported by an opinion of the general counsel of the Entity, or other counsel satisfactory to Stifel) that the Entity is duly organized and existing, that its charter empowers it to transact the business by these resolutions defined, and that no limitation has been imposed upon such powers by the By-Laws or otherwise.

**FOURTH:** That Stifel may rely upon any certification given in accordance with these resolutions as continuing fully effective unless and until Stifel shall receive due written notice of a change in or the rescission of the authority so evidenced and the dispatch or receipt of any other form of notice shall not constitute a waiver of this provision, nor shall the fact that any person hereby empowered ceases to be an officer of the Entity or becomes an officer under some other title in any way affects the powers hereby conferred. The failure to supply any specimen signature shall not invalidate any transaction if the transaction is in accordance with authority actually granted.

**FIFTH:** That in the event of any change in the office or powers or person hereby empowered, the President, Chairperson, Director, or Other Authorized Officer shall certify such changes to Stifel in writing in the manner hereinabove provided, which notification, when received, shall be adequate both to terminate the powers of the persons theretofore authorized, and to empower the persons thereby substituted.

**SIXTH:** That the foregone resolutions and the certificates actually furnished to Stifel by the President, Chairperson, Director, or Other Authorized Officer of the Entity pursuant thereto are hereby made irrevocable until written notice of the revocation thereof shall have been received by Stifel.

**SEVENTH:** That if the Entity has elected to hold a margin account with Stifel, as evidenced in writing executed by the Authorized Individual(s), the Entity is authorized to borrow against the securities of the Entity as collateral for a loan with Stifel, and the Entity will pay in cash or by checks and/or drafts drawn upon the funds of the Entity such sums as may be necessary in connection with any of the said accounts to deliver securities to and deposit funds with Stifel, including for the purpose of meeting margin calls.

I further certify that the said Entity is duly organized and existing and has the power to take action called for by the resolutions annexed hereto.

IN WITNESS WHEREOF, I have hereunto affixed my hand this 18th day of April, 2023

*(President, Chairperson, Director, or Other Authorized Officer Signature)*

**Ben Sheppard, Commission President**

*(Printed Name and Title)*

### SOPHISTICATED MUNICIPAL MARKET PROFESSIONAL CERTIFICATION

By checking this box, you acknowledge that you are a sophisticated municipal market professional as defined in Section 16(c). No Investment Advice or Recommendations in the Safekeeping Agreement and in Municipal Securities Rulemaking Board Rule D-15 that is (1) capable of evaluating investment risks and market value independently, both in general and with regard to all transactions and investment strategies involving a municipal security or securities; and (2) will exercise independent judgment in evaluating any recommendations made by Stifel.

If the box above is selected, enter the additional information below:

Your institution is organized as a:  corporation,  trust,  LLP,  LP, etc.

As of \_\_\_\_\_, 20\_\_\_\_ *(Insert specific date)*, the undersigned owns, or manages for the account of others, USD \$ \_\_\_\_\_ *(Insert specific dollar amount)* in \_\_\_\_\_ *(market, par)* value of municipal securities in its portfolio (as defined in Securities Exchange Act, Section 3(a)(29)).

### INSTITUTIONAL INVESTOR CERTIFICATION

By checking this box, you acknowledge that you are an Institutional Account as defined by FINRA Rule 4512(c) that is (1) capable of evaluating investment risks independently, both in general and with regard to all transactions and investment strategies involving a security or securities; and (2) will exercise independent judgment in evaluating any recommendations made by Stifel. If you are not an Institutional Account as defined by FINRA Rule 4512(c), you will be required to provide additional information to Stifel.

### AUTOMATIC CASH INVESTMENT SERVICES ELECTION

Deposit in Dreyfus Treasury Securities Cash Management Fund, (DIRXX) CUSIP 261941108

I (we) decline consent to having available cash balances at Stifel designated for credit interest payments. No interest will be accrued on available cash balances.

I (we) consent to having available cash balances at Stifel held as a Free Credit Balance, in accordance with Rule 15c3-3 under the Securities Exchange Act of 1934 (17 C.F.R. Section 240.15.3-3), designated for credit interest payments.

### SUBSTITUTE IRS FORM W-9 – TAX CERTIFICATION

Under penalties of perjury, you certify that: 1) the number you have included in this Safekeeping Agreement is your correct taxpayer identification number (or you are waiting for a number to be issued); 2) you are not subject to backup withholding because: a) you are exempt from backup withholding, b) you have not been notified by the Internal Revenue Service (IRS) that you are subject to backup withholding as a result of a failure to report all interest and dividends, or c) the IRS has notified you that you are no longer subject to backup withholding; 3) you are a U.S. Citizen or other U.S. person (as defined in general instructions); and 4) you are exempt from FATCA reporting on your Account(s) held at Stifel. Certification Instructions: You must cross out item 2 above if you have been notified by the IRS that you are currently subject to backup withholding because you have failed to report all interest and dividends on your tax return. For real estate transactions, item 2 does not apply. For mortgage paid, acquisition or abandonment of secured property, cancellation of debt, contributions to an individual retirement arrangement (IRA), and generally payments other than interest and dividends, you are not required to sign the certification, but you must provide your correct TIN. If you, at any time, become subject to backup withholding following the opening of your account(s), you agree that you will promptly notify Stifel in writing. You acknowledge and agree that the IRS does not require your consent to any provision of Section 10(d) of the Safekeeping Agreement other than the certification required to avoid backup withholding.

## 1. Arbitration.

General. This Agreement contains a predispute arbitration agreement. By signing an arbitration agreement, the parties agree as follows:

- a. All parties to this Agreement are giving up the right to sue each other in court, including the right to a trial by jury, except as provided by the rules of the arbitration forum in which a claim is filed.
- b. Arbitration awards are generally final and binding; a party's ability to have a court reverse or modify an arbitration award is very limited.
- c. The ability of the parties to obtain documents, witness statements, and other discovery is generally more limited in arbitration than in court proceedings.
- d. The arbitrators do not have to explain the reason(s) for their award unless, in an eligible case, a joint request for an explained decision has been submitted by all parties to the panel at least 20 days prior to the first scheduled hearing date.
- e. The panel of arbitrators may include a minority of arbitrators who were or are affiliated with the securities industry.
- f. The rules of some arbitration forums may impose time limits for bringing a claim in arbitration. In some cases, a claim that is ineligible for arbitration may be brought in court.
- g. The rules of the arbitration forum in which the claim is filed, and any amendments thereto, are incorporated into this Agreement.

Disputes Subject to Arbitration. Stifel and you (for yourself and on behalf of your principals, agents, beneficiaries, successors, heirs, and assigns) agree that all claims, controversies, and disputes between you and Stifel, Stifel's agents, employees, officers, and directors, any entity affiliated with Stifel that is a FINRA member firm, and/or any clearing agent of Stifel (collectively "Disputes") shall be resolved by binding arbitration before FINRA Dispute Resolution.

Stifel and you agree that all Disputes shall be arbitrated whether the Disputes arose prior to, on, or subsequent to the date hereof. Stifel and you further agree that Disputes includes, but is not limited to, claims, controversies, and disputes concerning, relating to, or arising from:

- i. Any account maintained by you at any time with Stifel, any entity affiliated with Stifel that is a FINRA member firm, or any clearing agent of Stifel, whether maintained by you individually and for your own benefit, jointly with any other person or entity, or in any representative capacity, including, but not limited to, as a trustee or guardian;
- ii. Any account in which you claim a beneficial interest maintained by any person other than you with Stifel, any entity affiliated with Stifel that is a FINRA member firm, or any clearing agent of Stifel;
- iii. Any transaction involving Stifel or any predecessor or successor firms by merger, acquisition, or other business combination and you, whether you acted individually, jointly with another person, or in a representative capacity and whether or not such transaction occurred in an account referenced in (i) or (ii) above;
- iv. Any recommendation of any securities transaction or investment strategy involving securities, including a recommendation of a type of account, made by Stifel or any predecessor or successor firms by merger, acquisition, or other business combination to you, whether or not the recommendation resulted in a securities transaction in an account referenced in (i) or (ii) above;
- v. The construction, performance, or breach of this Agreement or any other agreement between you and Stifel, any entity affiliated with Stifel that is a FINRA member firm, and/or any clearing agent of Stifel; or
- vi. The business activities of Stifel, an associated person of Stifel, any entity affiliated with Stifel that is a FINRA member firm, and/or any clearing agent of Stifel.

Stifel and you agree that any issue concerning the validity, enforceability, or scope of the arbitration agreement, including the arbitrability of a particular claim, controversy, or dispute, shall be resolved by binding arbitration before FINRA Dispute Resolution.

The Arbitration Forum. Any and all Disputes shall be submitted exclusively to FINRA Dispute Resolution and administered under the then current FINRA Code of Arbitration Procedure for Customer Disputes and other applicable FINRA rules, as amended from time to time (collectively, the “FINRA Code of Arbitration Procedure”).

Arbitration Hearing Locale. The hearing location for any arbitration of any Dispute in accordance with this Agreement shall be determined by the FINRA Director of Dispute Resolution in accordance with the FINRA Code of Arbitration Procedure.

Enforcement of This Arbitration Agreement. This arbitration agreement shall be enforced and interpreted exclusively in accordance with applicable federal laws of the United States, including the Federal Arbitration Act.

If you file any Disputes in court, Stifel may seek to compel arbitration of the Disputes, and you agree not to oppose any efforts to compel arbitration of such Disputes.

Judgment confirming any arbitration award in any arbitration conducted in accordance with this Agreement may be entered in any court having jurisdiction.

This arbitration agreement shall survive the termination of this Agreement.

Class Actions. No person shall bring a putative or certified class action to arbitration. No person shall seek to enforce any predispute arbitration agreement against any person who has initiated in court a putative class action; or who is a member of a putative class who has not opted out of the class with respect to any claims encompassed by the putative class action until: (i) the class certification is denied; or (ii) the class is decertified; or (iii) the customer is excluded from the class by the court. Such forbearance to enforce an agreement to arbitrate shall not constitute a waiver of any rights under this Agreement except to the extent stated herein.

A copy of this arbitration agreement is hereby given to you, and you acknowledge receipt thereof by signing the Signature Document and/or Agreement Confirmation provided to you.

2. **Waiver of Rights to Trial by Jury.** In the unlikely event any controversy or dispute between you and Stifel is determined to be ineligible for arbitration or not required to be arbitrated, you agree as follows: **THE PARTIES TO THIS AGREEMENT SHALL NOT EXERCISE ANY RIGHTS THEY MAY HAVE TO ELECT OR DEMAND A TRIAL BY JURY. YOU AND STIFEL HEREBY EXPRESSLY WAIVE ANY RIGHT TO A TRIAL BY JURY.** You acknowledge and agree that this provision is a specific and material aspect of the agreement between the parties and that Stifel would not enter into this Agreement with you if this provision were not part of the agreement.
3. **Forum Selection Clause.** Without limiting in any respect the arbitration agreement in Section 23 of this Agreement and your agreement and obligation to arbitrate all Disputes, any suit, claim, or action filed against Stifel or its present or past parents, subsidiaries, affiliates, officers, agents, or employees in court shall be brought and heard only in the State of Missouri in St. Louis County Circuit Court. Entering into the Agreement constitutes your consent to submit to the personal jurisdiction of the courts of the State of Missouri. You hereby waive any objection based on forum non conveniens and any objection to venue in relation to any such any action.

This paragraph shall apply even if you have related disputes with other parties that cannot be resolved in the same locale.

**Authorization Signature(s)**

I (we) agree to the terms and conditions of the above Agreement and attest that the certifications made on the W-9 above are true.

**BY SIGNING, YOU ACKNOWLEDGE THAT YOU ARE AWARE THAT THIS AGREEMENT CONTAINS A BINDING ARBITRATION PROVISION THAT MAY BE ENFORCED BY THE PARTIES.**

	Ben Sheppard, Commission President	4/18/2023
<i>(Name)</i>	<i>(Printed Name and Title of Authorized Officer)</i>	<i>(Date)</i>

<i>(Name)</i>	<i>(Printed Name and Title of Authorized Officer)</i>	<i>(Date)</i>

Required: 93-6002559  
*(Firm Tax Identification Number)*



## SCHEDULE A

### Fee Schedule

This Schedule A shall be amended upon delivery by Stifel of a new Schedule A to you and shall be effective as of the date of receipt by you or a date mutually agreed upon by Stifel and you.

<b>Fee Type</b>	<b>Fee Amount</b>
Account Maintenance (Per Position, Per Month)	\$0
Transaction Fee (Security Deposit/Withdrawal) Inside Trade	\$0
Transaction Fee (Security Deposit/Withdrawal) Outside Trade	\$0
Statement of Assets	\$0
Registration Fee	\$0
Wire Charge	\$0
Monthly Minimum Fee	\$0
Interest on Overdrafts in the Account	\$0

All out-of-pocket expenses will be charged directly to the Account at the time these expenses are incurred. These costs include, but shall not be limited to, all shipping costs, telegraphic transfer fees, re-registration/transfer fees, postage, insurance, expenses imposed by other agents, etc. Stifel may change any of the fees from time to time with or without notice to you. Your Securities Account will be automatically debited for all applicable fees.

Dear Valued Client:

All of us at Stifel would like to thank you for the opportunity to serve your financial needs. An integral component of that service is providing you continued access to your accounts. In today's world of electronic communications and networked businesses, various events could interrupt primary routines of conducting business (power outages, natural disasters, etc.). We would like to take this opportunity to assure you that we have plans in place for continuing service to our clients during emergencies or other business disruptions.

In the event of various levels and types of disruptions that could occur, from natural or manmade incidents, Stifel maintains service, communication, and processing systems that are networked and accessible from other Stifel locations. Stifel also conducts frequent backup of system information that is maintained in multiple locations and secure offsite locations. In the case of a significant event, Stifel has access to certain critical systems in alternative geographic regions. In addition, our primary business and servicing partners have developed similar plans and backup systems.

The varying scenarios that we have planned for include disruptions that would affect a branch office, the home office building, a surrounding business district, an entire city, or a general geographic region, as well as firm-wide issues. In the event of a public health crisis that resulted in a high rate of employee absences, Stifel would focus available personnel on critical business functions that directly support client needs. Additionally, we would implement our workforce continuity plan, which includes social distancing and other actions to limit exposure and the spread of the outbreak. Stifel monitors and reviews the potential for a pandemic outbreak and the impacts that may result on the firm, including the creation of response strategies. Depending upon the severity of the disruption, we anticipate being able to provide you with the level of service you are accustomed to in a matter of minutes for a localized matter and within a few hours or a business day for a significant district or regional disruption. Many of our communications and support systems are designed to redirect to backup systems in the event of a critical disruption. Likewise, our internal systems are designed to continue communicating essential information to our client-facing organizations, who, in turn, will be able to communicate with you.

While no contingency plan can eliminate all risk of service interruption or temporarily impeded account access, we periodically assess and update our plan to mitigate all reasonable risk. As with any matters of this importance, we are continually reviewing and evaluating our business contingency plans to implement improvements, and as such, the plan and this notice are subject to modifications. This notice in its most current form will be posted on our website, [www.stifel.com](http://www.stifel.com).

Sincerely,

Stifel Financial Corp.

**FACTS**

**WHAT DOES STIFEL DO WITH YOUR PERSONAL INFORMATION?**

<b>Why?</b>	Financial companies choose how they share your personal information. Federal law gives consumers the right to limit some but not all sharing. Federal law also requires us to tell you how we collect, share, and protect your personal information. Please read this notice carefully to understand what we do.
<b>What?</b>	The types of personal information we collect and share depend on the product or service you have with us. This information can include: <ul style="list-style-type: none"> <li>▪ Social Security number and income</li> <li>▪ Investment experience and account balances</li> <li>▪ Credit card/other debt and credit history</li> </ul>
<b>How?</b>	All financial companies need to share customers’ personal information to run their everyday business. In the section below, we list the reasons financial companies can share their customers’ personal information; the reasons Stifel chooses to share; and whether you can limit this sharing.

Reasons we can share your personal information	Does Stifel share?	Can you limit this sharing?
<b>For our everyday business purposes –</b> such as to process your transactions, maintain your account(s), respond to court orders and legal investigations, or report to credit bureaus	Yes	No
<b>For our marketing purposes –</b> to offer our products and services to you	Yes	Sometimes
<b>For joint marketing with other financial companies</b>	Yes	No
<b>For our affiliates’ everyday business purposes –</b> information about your transactions and experiences	Yes	No
<b>For our affiliates’ everyday business purposes –</b> information about your creditworthiness	Yes	Yes
<b>For our affiliates to market to you</b>	Yes	Yes
<b>For nonaffiliates to market to you</b>	No	We Don’t Share

<b>To limit our sharing</b>	<ul style="list-style-type: none"> <li>▪ Visit us online: <a href="http://www.stifel.com/privacy">www.stifel.com/privacy</a>, then click on <i>Privacy Opt Out</i> or</li> <li>▪ Call (877) 816-4779 – our menu will prompt you through your choice(s)</li> </ul> <p><b>Please note:</b></p> <p>If you are a <i>new</i> customer, we can begin sharing your information 30 days from the date we sent this notice. When you are <i>no longer</i> our customer, we continue to share your information as described in this notice.</p> <p>However, you can contact us at any time to limit our sharing.</p>
-----------------------------	--

<b>Questions?</b>	Call (877) 816-4779 or go to <a href="http://www.stifel.com/privacy">www.stifel.com/privacy</a>
-------------------	---



<b>Who we are</b>	
<b>Who is providing this notice?</b>	An affiliate or subsidiary of Stifel Financial Corp. (“Stifel”)
<b>What we do</b>	
<b>How does Stifel protect my personal information?</b>	To protect your personal information from unauthorized access and use, we use security measures that comply with federal law. These measures include computer safeguards and secured files and buildings.
<b>How does Stifel collect my personal information?</b>	<p>We collect your personal information, for example, when you:</p> <ul style="list-style-type: none"> <li>▪ Open an account with us or apply for a loan</li> <li>▪ Make deposits or withdrawals from your account</li> <li>▪ Give us your income information or provide employment history</li> </ul> <p>We also collect your personal information from others, such as credit bureaus, affiliates, or other companies.</p>
<b>Why can’t I limit all sharing?</b>	<p>Federal law gives you the right to limit only:</p> <ul style="list-style-type: none"> <li>▪ Sharing for affiliates’ everyday business purposes – information about your creditworthiness</li> <li>▪ Affiliates from using your information to market to you</li> <li>▪ Sharing for nonaffiliates to market to you</li> </ul> <p>State laws and individual companies may give you additional rights to limit sharing. See “Other important information (continued).”</p>
<b>What happens when I limit sharing for an account I hold jointly with someone else?</b>	Your choices will apply to everyone on your account.

<b>Definitions</b>	
<b>Affiliates</b>	<p>Companies related by common ownership or control. They can be financial and nonfinancial companies.</p> <ul style="list-style-type: none"> <li>▪ <i>Our affiliates include financial companies such as: Stifel, Nicolaus &amp; Company, Incorporated; 1919 Investment Counsel, LLC; B&amp;F Capital Markets, Inc.; Stifel Independent Advisors, LLC (fka Century Securities Associates, Inc.); EquityCompass Investment Management, LLC; Keefe, Bruyette &amp; Woods, Inc. (KBW); Thomas Weisel Partners, LLC; Washington Crossing Advisors, LLC; Stifel Bank &amp; Trust; Stifel Bank; Stifel Trust Company, National Association; or Miller Buckfire &amp; Company, LLC.</i></li> </ul>
<b>Nonaffiliates</b>	<p>Companies not related by common ownership or control. They can be financial and nonfinancial companies.</p> <ul style="list-style-type: none"> <li>▪ <i>Nonaffiliates we share with can include credit bureaus, closing agents, card processors, check printers, mutual fund companies, annuity companies, insurance companies, internet banking service providers, and vendors who perform marketing services on our behalf.</i></li> </ul>
<b>Joint marketing</b>	<p>A formal agreement between nonaffiliated financial companies that together market financial products or services to you.</p> <ul style="list-style-type: none"> <li>▪ <i>We do not have joint-marketing agreements with nonaffiliated third parties.</i></li> </ul>

## Other important information

In this notice, “Stifel,” “We,” “Our,” and “Us” refer to the specific affiliate with whom you have a relationship. All other Stifel affiliates are simply referred to as “affiliates.”

If your Financial Advisor’s affiliation with our firm ends, and they join a non-affiliated securities broker-dealer, your Financial Advisor may be permitted to use limited information to contact you to join their new firm, as a usual means to continue to serve and maintain your accounts. The information they may use is limited to your name, address, e-mail address, phone number, and account title.

**Do Not Call Policy.** This notice is the Stifel Do Not Call Policy under the Telephone Consumer Protection Act. We do not solicit via phone numbers listed on the state or federal Do Not Call lists, unless the law permits. Consumers who ask not to receive telephone solicitations from Stifel will be placed on the Stifel Do Not Call list and will not be called in any future solicitations, including those of Stifel affiliates. If you communicate with us by telephone, we may monitor or record the call.

**European Personal Data.** Where personal data of individuals in the United Kingdom or the European Economic Area is processed by Stifel Financial Corp. or its affiliates in the U.S. in relation to the offering of products or services to such individuals, or in relation to monitoring of such individuals’ online behavior, then, in addition to the above, Stifel will comply with the provisions of the Stifel Europe Privacy Notice (available at [www.stifel.com/EUprivacy](http://www.stifel.com/EUprivacy)) with respect to such processing. In such cases, references to “Stifel” in the Stifel Europe Privacy Notice shall be deemed to be references to the relevant U.S. entity and, if there is any inconsistency between any provision of this notice and the Stifel Europe Privacy Notice, Stifel will comply with the provision of the Stifel Europe Privacy Notice.

**Nevada:** We are providing you this notice pursuant to state law. You may be placed on our internal Do Not Call List by following the directions in the “Can you limit this sharing” section by choosing to limit sharing “For our affiliates to market to you.” Nevada law requires that we also provide you with the following contact information: Bureau of Consumer Protection, Office of the Nevada Attorney General, 555 E. Washington Street, Suite 3900, Las Vegas, NV 89101; Phone number: (702) 486-3132; e-mail: [BCPINFO@ag.state.nv.us](mailto:BCPINFO@ag.state.nv.us). Stifel Financial Corp., 501 North Broadway, Saint Louis, MO 63102; Phone Number (314) 342-2000; e-mail: Click on “Contact Us” at the top of the page at [www.stifel.com/privacy](http://www.stifel.com/privacy).

**Vermont:** In accordance with Vermont law, we will not share information we collect about Vermont residents with companies outside of our corporate family, except as permitted by law, such as with your consent, to service your accounts or to other financial institutions with which we have joint marketing agreements. We will not share information about your creditworthiness within our corporate family except with your authorization or consent, but we may share information about our transactions or experiences with you within our corporate family without your consent.

**California:** Where Stifel collects personal information of California residents, then, in addition to the above, Stifel will comply with the provisions of its California Privacy Policy (available at [www.stifel.com/privacy](http://www.stifel.com/privacy)) with respect to such personal information. If there is an inconsistency between any provision of this notice and the aforementioned California Privacy Policy, for California residents, Stifel will comply with the California Privacy Policy.

**For Insurance Customers in AZ, CA, CT, GA, IL, ME, MA, MN, MT, NV, NJ, NC, OH, OR, and VA only.** The term “Information” in this part means customer information obtained in an insurance transaction. We may give your Information to state insurance officials, law enforcement, group policy holders about claims experience, or auditors as the law allows or requires. We may give your Information to insurance support companies that may keep it or give it to others. We may share medical Information so we can learn if you qualify for coverage, process claims, or prevent fraud or if you say we can. To see your Information, contact the employee who services your account by mail or telephone. You must state your full name, address, the insurance company, policy number (if relevant), and the Information you want. We will tell you what Information we have. You may see and copy the Information (unless privileged) at our office or ask that we mail you a copy for a fee. If you think any Information is wrong, you must write us. We will let you know what actions we take. If you do not agree with our actions, you may send us a statement.

**For MA Insurance Customers only.** You may ask in writing the specific reasons for an adverse underwriting decision. An adverse underwriting decision is where we decline your application for insurance, offer to insure you at a higher than standard rate, or terminate your coverage.

**Effective Date: May 24, 2021**



# STIFEL

**Investment Services Since 1890**

One Financial Plaza | 501 North Broadway | St. Louis, Missouri 63102  
Stifel, Nicolaus & Company, Incorporated | Member SIPC & NYSE | [www.stifel.com](http://www.stifel.com)

This page intentionally left blank.



# Commission Memo



Prepared by: Greg Hagbery  
Date: April 18, 2023  
Re: Lease Addendum No. 2 – Wolf Ceramics LLC

---

Wolf Ceramics, LLC has leased Suite 404 in the Big 7 since May 15, 2021, and grew to include Suite 403 on June 29, 2022. Wolf Ceramics LLC, which started in Portland, has been an excellent tenant and continues to see economic and employment growth as a handmade artisan ceramics and crafts studio.

Staff was adequately informed of the intention to utilize the final two (2) year extension option as afforded by Section 2 of their lease.

**RECOMMENDATION:** Approve Addendum No. 2 to Wolf Ceramics LLC Lease, for Suite 404 & 403 in the Big 7 Building.

This page intentionally left blank.

**ADDENDUM NO. 2 TO LEASE**

**Whereas**, the Port of Hood River ("Lessor") and Wolf Ceramics, LLC ("Lessee") entered into a Lease of Suite 404 in the Big 7 Building ("Building") located at 616 Industrial Street, in Hood River, Oregon, effective May 15, 2021 ("Lease"); and,

**Whereas**, pursuant to section 2 of the Lease, in 2022 Lessee timely exercised the first option to extend the Lease term for an additional one (1) year term, extending the expiration of the Lease to April 30, 2023; and

**Whereas**, Amendment No.1 added 1,429 square feet (Suite 403) of Leased Premises to the Wolf Ceramics Lease Agreement beginning June 22, 2022. The Base Rent and Additional Rent rates matched the rent rates for Wolf Ceramics' Lease Agreement for Suite 404; and

**Whereas**, Amendment No.1 included two designated parking spaces behind the Big 7 Building that are allotted for Suite 403; and

**Whereas**, pursuant to section 2 of the Lease, Wolf Ceramics seeks to exercise the second option to extend the Lease term for an additional two (2) year term, extending the expiration of the Lease to April 30, 2025; and

**Therefore**, Lessor and Lessee agree as follows:

1. Pursuant to section 2 of the Lease, the Lease term shall be renewed and extended for an additional one (2) year term and the Lease shall remain in effect through April 30, 2025.

Except as modified by Addendum No.1, Amendment No.1, and this Second Addendum to Lease, all terms and conditions of the Lease shall remain in full force and effect.

DATED THIS \_\_\_\_\_ DAY OF \_\_\_\_\_ 2023.

By: \_\_\_\_\_  
Kevin Greenwood, Port of Hood River, Executive Director

By: \_\_\_\_\_  
Sarah Wolf, Wolf Ceramics, LLC., Owner

This page intentionally left blank.

# Commission Memo



Prepared by: Debbie Smith-Wagar  
Date: April 18, 2023  
Re: Accounts Payable Requiring Commission Approval

---

**Motschenbacher & Blattner LLP** **\$8282.50**

Attorney services per attached summary

**TOTAL ACCOUNTS PAYABLE TO APPROVE** **\$8282.50**

This page intentionally left blank.



ATTORNEYS SERVING PRIVATELY HELD BUSINESSES AND THEIR OWNERS

# MOTSCHENBACHER & BLATTNER LLP

117 SW TAYLOR STREET, SUITE 300, PORTLAND, OR 97204-3029 PHONE 503-417-0500 FAX 503-417-0501

Campbell Phillips PC  
P.O. Box 2449,  
The Dalles, OR 97058

Statement Date 03/31/2023  
Statement Number 105267

Attn: Kristen A. Campbell

***We appreciate the opportunity to be of service to you!  
Summary of charges through 03/31/2023***

5667-002 Port of Hood River

Balance  
\$8,282.50

Due upon receipt. Late charges accrue on balances which are 30 days past due at 18% per annum.

Statements received by email include a secure link for payment by credit card or ACH. If you prefer to mail or fax your credit card information please fill out the slip below.

If paying by check please include your account number or remit the slip below. Thank you.

Please Charge \$ _____ on the following:		Amount Remitted: _____
<input type="checkbox"/> Visa	<input type="checkbox"/> MasterCard	Check No.: _____
<input type="checkbox"/> Discover		
<input type="text"/>	<input type="text"/>	Account No. 5667.002
Card Number	Exp. Date (mo./yr.)	
Card Mailing Address		
Card Holder Signature		

This page intentionally left blank.



# Commission Memo/Discussion Item



Prepared by: John Mann  
Date: April 18, 2023  
Re: Wire Ropes Fabrication Delays

---

Following award of contract and the beginning of fabrication it was discovered that the fabrication sub-contractor for the project was having a difficult time getting the wire ropes into fabrication. Hamilton Construction was under the understanding this work was well underway. This delay will push this project out into mid to late October, so we can avoid the summer traffic and the fruit harvest trucking.

The Port has prepared a change order for the project that will put in place a final project completion deadline of October 31, 2023. There will be \$10,000 liquidated damages assessed per day if this deadline is not met. Hamilton has agreed to this change order. This will not affect the physical work liquidated damages that are associated with not completing the physical work in the allotted 4 days (96 consecutive hours) of \$10,000 per hour.

Joe Hampton from Hamilton construction will attend the meeting to answer any questions the board may have about the delays.

**RECOMMENDATION:** Discussion.

This page intentionally left blank.

# Commission Memo / Discussion Item



Prepared by: Kevin Greenwood/Genevieve Scholl  
 Date: April 18, 2023  
 Re: Commencing Process for Funding the Hood River Bridge Replacement

The Washington State Transportation Commission (“WSTC”) is conducting an independent Traffic and Revenue Analysis as part of Washington SB 5689. The WSTC technical staff has recommended that WSTC move ahead with detailed analysis of two potential toll scenarios that were developed in coordination with the BSWG. Final concurrence on these scenarios will be made at the WSTC’s April 18 meeting. It is important to note the information provided by WSTC to BSWG is for information only and is not a recommendation or guarantee of funds. Pictured below are the two scenarios being analyzed:

## Preliminary WSTC Direction: Final Two Tolling Scenarios

FY 24 – FY 30 toll rates align with BSWG Scenario 3 (\$1.75/3.50) & Scenario 5 (\$2.00 / \$3.00)

FY 31 – FY 51 toll rates are preliminary, pending verification of ability to meet estimated financial capacity targets

Existing Toll Rates		BreezeBy	\$1.00
		Cash / CC	\$2.00
			Scenario A
			Scenario B
<i>Pre-Completion (FY 24-30)</i>			<i>FY 24 Increase by \$1.00 for BreezeBy &amp; \$1.50 for Cash</i>
FY 24	BreezeBy	\$1.75	\$2.00
	Cash / CC	\$3.50	\$3.00
FY 30	BreezeBy	\$1.75	\$2.00
	Cash / CC	\$3.50	\$3.00
<b>Estimated Reserves Target (pending)</b>			<b>\$15-20 million</b>
<i>Post Completion (FY 31-51)</i>			<i>15% Increase every 5 yr starting in FY 36 (BreezeBy)</i>
FY 31	BreezeBy	\$2.00	\$2.50
	Video	\$4.00	\$5.00
FY 51	BreezeBy	\$3.50	\$4.45
	Video	\$5.50	\$8.75
<b>Estimated Financial Capacity Target</b>			<b>\$125 million</b>

The primary purpose for implementing a toll increase now is to generate necessary reserves to be eligible for a US Dept. of Transportation (USDOT) Transportation Infrastructure Finance and Innovation Act (TIFIA) loan to complete the financing. Currently the bridge financing plan includes \$125M each from Oregon and Washington, \$200M from the Federal Highways (FHWA) with the balance of \$75M-\$125M to be made up from tolls to service the TIFIA loan payments.

In addition, the BSWG and the Port’s Government Affairs consultants have been busy advocating for state and federal funding. The project team will be making their fourth trip to

Washington DC in May 2023 in less than 12 months. A recurring theme from both state and federal decision makers is to what degree the locals are willing to contribute to the project.

Though there is a state and federal expectation that tolls will increase to help fund the bridge replacement effort, it cannot happen overnight. In 2017, the decision to raise tolls started as part of the Port’s budget process in May 2017 resulting in a toll rate resolution in December 2017 less than two months before the increase started February 1. There was a robust public input process that included two hearings and media coverage to explain the increase, the need for the increase and other details surrounding the increase. Time was also needed to prepare signage, train staff and program the software.

For this effort, it will be equally important to ensure that the BSWG and Port Commission along with staff and consultants develop a public, transparent process that allows toll payers an opportunity to ask questions and understand the reasons for the increase. There are two main components of any toll adjustment implementation: (1) public outreach and (2) technical implementation.

**PUBLIC OUTREACH**

A critical part of any toll implementation is the development of a public outreach campaign. This will need to be developed jointly with the Port Commission and BSWG with support from staff and the consulting team. The resolution to be considered later this evening directs staff to work with HNTB (project management firm) and JLA (communications firm) to develop this plan and bring it to the Commission for approval. The types of activity include scheduling and developing open houses, informing the public on the financing plan, explaining the need for the TIFIA loan, how tolls will be monitored and used, and an introduction to the new Hood River White Salmon Bridge Authority (HRWSBA) which will be taking over the bridge replacement project upon its formation in July of this year.

As the public outreach strategy is developed, the milestones, dates, and responsible parties will be added to the technical implementation schedule.

**TECHNICAL IMPLEMENTATION**

The following is a draft schedule for required Port Commission and Staff Action related to technical issues related to a toll increase implementation. This schedule does not include public outreach activities as those will need to be developed jointly with the BSWG and the consulting team.

MILESTONE	DATE	RESPONSIBLE STAFF	COMMISSION ACTION
Budget Committee Meeting	May 2, 2023	Kevin Greenwood, Debbie Smith-Wagar, Budget Committee	<ul style="list-style-type: none"> <li>▪ Elect Budget Committee Chair</li> <li>▪ Discussion of Budget &amp; Budget</li> </ul>

			<p>Message</p> <ul style="list-style-type: none"> <li>▪ Public Hearing</li> <li>▪ Discussion of Budget Proposal</li> <li>▪ Approve Budget, Tax Rate &amp; Proposed Tax Levy</li> <li>▪ Budget Committee Certifies Final Budget Document to Commission</li> </ul> <p>Review preliminary staff recommended FY 23-24 budget. Toll increase and BSBA financial agreement will be included.</p> <p>Creation of Bridge Bistate Replacement Fund.</p>
Orientation for new Port Commissioners elected April 25	May 10	Kevin Greenwood, Mike Fox, Kristi Chapman, Debbie Smith-Wagar, Genevieve Scholl	Welcome new commissioner(s) and provide onboarding training, current issues orientation.
Public notice of June 6 Budget Hearing during Commission meeting for Adoption of Budget & Tax Rate runs today (sent on May 19)	May 24 <sup>th</sup>	Genevieve Scholl, Debbie Smith-Wagar	None.
Budget Public Hearing during Regular Session. Resolutions to Enact Adoption of Budget and Tax Rate	June 6 <sup>th</sup>	Debbie Smith-Wagar, Kevin Greenwood	Hear public comment, pass resolutions to adopt FY 23-24 budget.
Adoption of budget if not adopted on June 6 <sup>th</sup> . Deadline for filing budget and deadline to certify resolutions.	June 15 <sup>th</sup>	Debbie Smith-Wagar	Only if budget not adopted on June 6.
Hood River White Salmon	July 1	Kevin Greenwood, Mike	None.

Bridge Authority begins operations		Shannon	
New Port Commissioner(s) swear oaths of office	July 11	Kevin Greenwood, Genevieve Scholl	Regular Session meeting.
Finalize design for all signs and paper collateral needed for Port operations.	July 25	Genevieve Scholl	Approve final designs.
Approve Toll Increase Resolution	July 25	Kevin Greenwood, Debbie Smith-Wagar, Mike Shannon	Approve Toll Increase Resolution.
Authorize PSquare to begin implementation in ETBOS test environment	July 26	Debbie Smith-Wagar, Kevin Greenwood, PSquare – Shane and Harish	Approve Task Order if over ED's authority threshold.
Order all signs and paper collateral needed for Port operations, customer service.	July 26	Genevieve Scholl	None.
All toll collector and customer service team meeting RE: toll increase and public messaging.	July 28	Debbie Smith-Wagar, Marcela Diaz, Kevin Greenwood, Genevieve Scholl  All toll and customer service staff.	None.
Distribute toll increase handouts at toll booth, display posters at office	July 31 – August 31, 2023	Toll Staff, Customer Service staff.	None.
Confirm toll increase changes implemented and checked in ETBOS test environment, ready to deploy.	August 15, 2023	Debbie Smith-Wagar, PSquare	Confirm toll increase changes implemented and checked in ETBOS test environment, ready to deploy.
Facilities crew install all new toll rate signage on approaches and toll booth.	August 30 or 31, 2023	John Mann, Ryan Klapprich	None.
Greenlight PSquare to deploy increase.	August 30, 2023	Debbie Smith-Wagar, PSquare	None.
Toll Increase begins	September 1, 2023	Debbie Smith-Wagar	None.

As noted in the technical schedule, the toll increase would begin September 1, 2023.

**RECOMMENDATION:** Discussion.

# Commission Memo/Discussion Item



Prepared by: Genevieve Scholl & Daryl Stafford  
Date: April 18, 2023  
Re: Waterfront Paid Parking

---

During the April 4 Spring Planning work session, the Commission directed staff to develop a proposed update to the Waterfront Parking Plan to gain greater efficiencies, reduce costs, and maximize revenue as part of the effort to end reliance on toll revenue subsidies for the maintenance and operation of Port-owned waterfront parks and open spaces. The Waterfront Parking Plan was first implemented in late June of 2018. Adjustments to the rate and fee schedule, rules and fines, and management of zones and kiosks have been made each year since implementation. Staff recommends the following changes to the parking system this year, which are recorded in Resolution 2022-23-12, an Action Item for tonight's meeting:

## ***PAY TO PARK ZONES AND HOURS***

**Payment for parking will be required between the hours of 8:00 a.m. and 6:00 p.m.** No parking is allowed on any Port-owned lots and streets between the hours of 11:00 p.m. and 6:00 a.m. There is no maximum stay limit for any designated parking space between the hours of 6:00 a.m. and 11:00 p.m.

**Zone 1:** Encompasses all Port-owned streets and parking lots west of Nichols Basin, except for the Event Site Parking Lot. (Nichols Basin parking lot, N. 1<sup>st</sup> Street, Lot 1, westernmost block of Portway Avenue, western half of the West Jensen Parking lot, easternmost block of Portway Avenue, and the Hook).

**Zone 2:** The Event Site Parking Lot (and Lot 1 overflow parking when full).

**Zone 3:** The Marina Boat Launch Parking Lot.

## ***FREE TO PARK ZONES AND HOURS***

**No payment is required for parking in the Spit Parking Lot, the Marina Beach Parking Lot, and the Marina Moorage Parking Lot.** The gates close to the Marina Park and Spit at 9:00p.m. All cars must be out before that time. The Marina moorage parking lot closes at 9:00p.m. except for Marina Tenant vehicles. No parking is allowed on any Port-owned lots and streets between the hours of 11:00 p.m. and 6:00 a.m.

## ***PARKING RATES & FEES***

Parking rates in all Zones will be \$2.50 per hour (per parking space occupied), up to \$15 per day for regular length vehicles, and \$25 per day for overlength vehicles parked at the Event Site.

Regular and overlength annual season passes valid for parking in the Event Site and Lot 1 overflow parking. Regular length passes valid at West Jensen, Overlength passes are not valid and overlength vehicles are prohibited. Passes cost \$200 for vehicles up to 20' and \$350 for vehicles over 20'. Passes are valid January 1 – December 31 for lot open hours only. Passes are not valid for on street parking.

#### ***VEHICLE TYPES ALLOWED IN PARKING LOTS***

**Event Site Parking Lot:** Gates are open 7:00 a.m. to 9:00 p.m. Payment required between 8:00 a.m. and 6:00 p.m. Regular Length Vehicles (up to 20' in total length) and Overlength Vehicles (over 20' in total length) are allowed. RVs, Campers, and trailers are allowed in designated overlength parking spots only. Regular length vehicles are not allowed to park in overlength parking spots. No parking allowed after 9:00p.m.

**West Jensen Parking Lot:** Open for parking 6a.m.-11p.m. Payment required between 8:00 a.m. and 6:00 p.m. Overlength Vehicles (over 20' in total length) are NOT allowed. No RVs, campers, buses, or trailers are allowed. Jensen tenant parking only on east half of lot.

**Nichols Basin Parking Lot:** Open for parking 6a.m.-11p.m. Payment required between 8:00 a.m. and 6:00 p.m. Regular Length Vehicles (up to 20' in total length) No Overlength vehicles, (over 20' in length). NO RVs, campers, buses, or trailers are allowed.

**Spit:** Gates are open 7:00 a.m. to 9:00 p.m. Parking is free. Regular Length Vehicles (up to 20' in total length). No overlength vehicles (up to 20' in total length). No RVs, campers, buses, or trailers are allowed. No parking allowed after 9:00 p.m.

**Marina Boat Launch Parking Lot:** Open for parking 6a.m.-11a.m. Payment required between 8:00 a.m. and 6:00 p.m. Regular Length Vehicles (up to 20' in total length) and Overlength Vehicles (over 20' in total length) are allowed.

**Marina Beach Parking Lot:** Gates are open 7:00 a.m. to 9:00 p.m. Parking is free. Regular Length Vehicles (up to 20' in total length) and Overlength Vehicles (over 20' in total length) are allowed. Commercial Trucks are not allowed. Commercial trucks are defined as a tractor or tractor trailer combination in excess of 10,000 gw. No parking allowed after 9:00 p.m.

**Marina Moorage parking lot** - Open for parking 6a.m.-9:00p.m, except for marina tenant vehicles. Parking is free. Regular Length Vehicles (up to 20' in total length) are allowed. No overlength vehicles (up to 20' in total length). No RVs, buses, trailers, or campers. Commercial Trucks are not allowed. Commercial trucks are defined as a tractor or tractor trailer combination in excess of 10,000 gw. No parking allowed in these lots after 9:00 p.m.

#### ***VEHICLE TYPES ALLOWED ON STREETS AND ROADS***

**The Hook:** Gates are open 7:00 a.m. to 9:00 p.m. Payment required between 8:00 a.m. and 6:00 p.m. Regular length vehicles (up to 20') only. Overlength Vehicles (over 20' in total length) are NOT allowed. No RVs, buses, trailers, or campers. Parking in designated spaces



only. Vehicles parked in FIRE ZONES or in any way impeding access of emergency response vehicles will be ticketed and towed at owner’s expense. Season Passes NOT valid.

**West Portway Avenue:** Open for parking 6a.m.-11p.m. Payment required between 8:00 a.m. and 6:00 p.m. Passenger vehicles allowed 7 days a week. Commercial trucks NOT allowed May 15 through October 15. Overnight parking for commercial trucks only allowed October 16 – May 14. Commercial trucks are defined as a tractor or tractor trailer combination in excess of 10,000 gvw.

**North 1<sup>st</sup> Street and East Portway Avenue:** Open for parking 6a.m.-11p.m. Payment required between 8:00 a.m. and 6:00 p.m. Passenger vehicles allowed 7 days a week. Commercial trucks NOT allowed May 15 through October 15. Commercial trucks are defined as a tractor or tractor trailer combination in excess of 10,000 gvw.

***VIOLATION PENALTIES***

<b>Complaint &amp; Late Payment Charges- approved 11/1/22</b>	<b>2023 VIOLATION FEES</b>	<b>2023 30+days</b>	<b>2023 60+days</b>	<b>2023 90+days</b>
<b>Non-Payment (Each Occupied Space)</b>	<b>\$50</b>	<b>\$20</b>	<b>\$20</b>	<b>\$20</b>
<b>Parking in Unauthorized Space</b>	<b>\$50</b>	<b>\$20</b>	<b>\$20</b>	<b>\$20</b>
<b>Car/Van Overnight Parking</b>	<b>\$90</b>	<b>\$40</b>	<b>\$40</b>	<b>\$40</b>
<b>Truck No-Pay/Time Expired (Zone 6)</b>	<b>\$50</b>	<b>\$40</b>	<b>\$40</b>	<b>\$80</b>
<b>H/C Ramp, Fire Lane, etc.</b>	<b>\$75</b>	<b>\$40</b>	<b>\$40</b>	<b>\$40</b>

- Non-payment of violation penalty after 90 days of issuance – Send to collections, will include collections fees assessed by Duncan Solutions.

***PAYMENT METHOD***

**All Zones: Pay-by-Text or Flowbird Mobile App only.** (No cash payment. No payment kiosks. No Event Site Parking Booth.)

**Event Site Parking Lot, Lot 1, and West Jensen Parking Lot: Annual season pass option** allowed in these lots. (No overlength passes/vehicles allowed in West Jensen lot).

Parking violation payment accepted by cash, check, or credit card at the Port office during regular business hours or via U.S Mail.

Staff recommends these changes to the system to simplify and unify parking rules and rates throughout the pay to park areas, align more closely with City of Hood River rules and rates, cut costs, maximize revenue while still offering some free-to-park public areas, and create new efficiencies in the administration and payment processes.

Commission direction is sought in particular on the following important changes that would be made with implementation of this plan:

- Closing the Event Site parking booth.
- Ending trucking company parking agreements on west Portway.
- Implementing paid parking at the Hook.
- Implementing paid parking in the Marina Boat Ramp parking lot.

**RECOMMENDATION:** Discussion.



Executive Director's Report  
April 18, 2023

#### **ADMINISTRATION – KEVIN GREENWOOD, EXECUTIVE DIRECTOR**

- *An updated Capital Improvement List is included in the packet for capital projects to be included in the FY 23-24 budget. Based on Commission feedback, the list includes columns for origins of funds, which fund or department the project will originate, and the justification for the project. Most of the projects are needed to keep currently existing revenue producers maintained and safe.*
- *Finance staff has been processing checks/credit card credits for accounts that have had no activity for several years or have moved out of the area. Almost 200 accounts have been purged from the Port's finance system and payment remitted.*
- *Took a tour of waterfront with Mike Schock, Columbia Gorge Windsurfers Association (CGWS) on April 13. It was great to get a first-hand understanding of how our user groups access the waterfront.*
- *Attended a Rotary tour of the Hood River Valley High School Career Technical Education (CTE) program along with Commissioner Sheppard. This has the potential to be an opportunity for the Port to hire summer help. I shared applications with Mr. Ruff, the high school metals teacher.*
- *Ryan Klapprich and Steve DePriest from the Port's facility staff attended ODOT's bridge maintenance training in Albany last week. Klapprich reported that pot holes in concrete (recently noticed on the north access ramp) may be occurring due to electrolysis. They learned about new patching compounds and learned new practices that should limit the holes. Also had sessions on timber epoxy repairs and environmental hazards.*
- *We have received delivery of the bronze sculpture to replace the piece that was stolen from Frog Beach last year. Artist Ralph Tretheway and the Valley Bronze foundry in Joseph provided the replacement at a discount cost, and the property insurance claim money received helped to secure the replica piece at low cost to the Port. The statue is one of the most beloved public artworks on the waterfront. Facilities Crew are working on a secure pedestal for installation later in the month.*
- *Staff has been in contact with multiple parties hoping to support efforts to remove the fish wheel apparatus from the Sandbar. Cindy Thieman, Executive Director of the Hood River Watershed Group, has learned that the apparatus was originally owned by the Yakama Nation for a shad eradication pilot project, and that they are working to assist the current owner with its removal. Port staff has received several emails and complaints from waterfront users that it poses a hazard to recreational users in that area.*

- *Attached is the latest Columbia Gorge Economic Indicators report from the Oregon Employment Department.*
- *Also attached is a letter from Jessica Metta, Executive Director of the Mid-Columbia Economic Development District, providing an update to the priority ranking list for the regional Comprehensive Economic Development Strategy list.*
- *On April 13 I was invited to attend the meeting of the Warm Springs Tribal Council to discuss with them the bridge replacement project and to request a letter of support for federal grant applications.*
- *The Hood River Rotary Club will host a candidate forum for the Port Commission Position 5 candidates during their lunch meeting on May 11.*
- *Terra Lingley of ODOT has arranged a date for Commissioners to tour the Mitchell Point tunnels project on April 25, 2:00PM – please RSVP through me.*
- *We received the attached usage report for the FORTH mobility electric car share program vehicle hosted by the Port on N. 1<sup>st</sup> street. Please see accompanying email from FORTH summarizing the challenges the program has faced in the past two years.*
- *Campbell Phillips will be working with a human resources consultant from HR Answers to guide the process for my 6-month performance evaluation. Commissioners should expect to receive communication directly from Campbell Phillips staff to begin this process.*

#### **FINANCE – DEBBIE SMITH-WAGAR, FINANCE DIRECTOR**

- *The Finance Department is helping other departments put together plans for next steps to stop backfilling business center deficits with toll revenue. Greg Hagbery is reviewing a 2014 condition assessment of all buildings to see if everything recommended at that time was done. Another all-building assessment will most likely be conducted in the next fiscal year to see what has changed in the last nine years. We will follow up at the budget committee meeting on May 2<sup>nd</sup> with more information on what we expect to accomplish in the next fiscal year.*
- *We are moving forward with an assessment of software needs. Merina + Company has reached out to stakeholders to find out needs and wants. The next step will be to start putting those into an RFP.*
- *A new credit card machine has FINALLY arrived for the toll booth. Our IT contractor installed it on Friday. The machine became almost unusable on March 15<sup>th</sup>, but the vendor, Verifone, was not able to ship out a replacement in a timely manner, even when we offered to pay for expedited service. Upper management from Verifone got involved and we have signed an updated agreement that will hopefully resolve this problem for future issues. The other*

*credit card machine is also acting up, so we have requested a second replacement and a spare in case this continues to be a problem.*

#### **RECREATION/MARINA – DARYL STAFFORD, WATERFRONT MANAGER**

- *The Port has a new food concession, Hood River Hot Dogs, LLC. Zach Mitchell from Parkdale has a small mobile hot dog stand that will be set up at the Event Site to the left of the entrance where the Photography Shed used to be. It is a new cart, and a new venture for Zach. He and his family are frequent users of the waterfront and would like to offer a lower cost alternative for a quick bite to eat. Staff are excited to welcome him to our concession line up!*
- *Water levels are coming back up as we edge into Spring along with users of the Event Site. Our facility crew will chalk the kite launch pad once we pass this next bout of rain. The Port allows kite launching and landing from the grass until the crowds become too large to manage, then all launching and landing moves to the sandbar.*
- *The Hood River Outrigger Canoe Club has set up for the season at Nichols Basin. Sherry Bohn, club President and former Port Commissioner, has sent the Commission an update of club news, see attached.*
- *This coming weekend is the 6<sup>th</sup> Annual 24-Hour Paddle for Cancer at Frog Beach. Paddlers from the area raise money for local families that have a loved one battling cancer.*

#### **DEVELOPMENT/PROPERTY – GREG HAGBERY, DEVELOPMENT & PROPERTY MANAGER**

- *The Evaluation Committee is in the process of reviewing submittals for the Anchor Way and First Street CE Design RFP. Per the review schedule, a report will be presented at the May 16<sup>th</sup> meeting.*
- *Staff is actively marketing the vacated space in the Big 7 building. Some specific spaces are challenging to provide functional Light Industrial access. Staff is researching the feasibility of modernizing the decommissioned service elevator to provide greater flexibility and value for the building overall.*
- *Staff is exploring costs to have all buildings re-keyed to provide easier emergency access and improved organization of the building key catalogue.*
- *Port administrative staff will continue touring each of our facilities and meeting our tenants in person. The previous tenants that were visited appreciated the opportunity to meet the new senior staff.*
- *pFriem will be installing additional security lights behind the Halyard building to provide additional safety for employees and guests.*

**AIRPORT – GREG HAGBERY, DEVELOPMENT & PROPERTY MANAGER**

- *Staff met with DSL and Ecological Land Services to discuss alternative strategies to bring the wetland mitigation project into compliance with allowable invasive species. Ecological Land Services will provide a new plant species program and maintenance procedure for DSL review.*
- *Staff is continuing to research solar opportunities and capabilities at the airport. MCEDD provides a 90% grant for a design/feasibility study. Further information on the load bearing capacity of our T-Hangar structures is required from a structural engineer.*
- *The AWOS project, funded through the FAA CIP grant program, will be delayed until the next FAA budget cycle due to extended timeframes for engineering reviews by the FAA.*
- *Staff is working with our contracted airport engineering firm, PAE to develop rough order of magnitude costs for T-Hangar construction on the South Apron. The assessment considers the use of Bipartisan Infrastructure Law (BIL) funding available through the FAA which allows for vertical construction.*
- *The FBO report for the month of March is attached.*

**BRIDGE/TRANSPORTATION – JOHN MANN, FACILITIES DIRECTOR**

- *John has been on a much deserved vacation with family for the week of April 10. He will return April 17.*

*-###-*

Capital Projects Tracking List										
Priority	1 - Short Term (next budget year): 2 - Near Term (2-3 years); 3 - Mid Term (4-10); 4 - Long Term (more than 10)		Project Title	Estimate	Department	Grant	Source	Net to Cash	Purpose	ROI Opportunity
	Budget Year	Year								
1	23/24	Airport	Repair Wetland (No. Apron Development)	\$30,000	Airport	-	Airport Net Revenue	(\$30,000)	Mitigation	Next Phase
1	23/24	Airport	AWOS- Wind sock relocation study	\$75,000	Airport	\$ 74,250.00	FAA Grants	(\$750)	Safety	n/a
1	23/24	Airport	SDS Hangar Repairs	\$60,000	Airport	-	Airport Net Revenue	(\$60,000)	Building Maintenance	maintain revenue
2	24/25	Airport	South Apron T-Hangars Phase 1: Prep/PE	\$100,000	Airport	\$ 50,000.00	FAA/Airport Net Rev	(\$50,000)	Building Maintenance	Next Phase
2	24/25	Airport	Paint FBO Building	\$20,000	Airport	-	Paint White Hangar			
2	24/25	Airport	AWOS- Wind sock relocation	\$180,000	Airport	-	AWOS- Wind sock relocation			
2	24/25	Airport	South Apron T-Hangars Phase 2: Final Design/Const.	\$1,400,000	Airport	-	South Apron T-Hangars Phase 2: Final Design/Const.			
1	23/24	Bridge	Lift Span Wire Rope Replacement (WIP)	\$1,600,000	Bridge	-	Repair Reserves	(\$1,600,000)	Bridge CIP	maintain revenue
1	23/24	Bridge	Underwater Pier Cap 6 & 8 Concrete Repairs (WIP)	\$500,000	Bridge	-	Repair Reserves	(\$500,000)	Bridge CIP	maintain revenue
1	23/24	Bridge	Misc. Steel Repairs (WIP)	\$100,000	Bridge	-	Repair Reserves	(\$100,000)	Bridge CIP	maintain revenue
1	23/24	Bridge	Maintenance Painting	\$600,000	Bridge	-	Repair Reserves	(\$600,000)	Bridge CIP	maintain revenue
1	23/24	Bridge	Scour Evaluation (Subsurface)	\$16,000	Bridge	-	Repair Reserves	(\$16,000)	Bridge CIP	maintain revenue
1	23/24	Bridge	Rehab Live Loads	\$100,000	Bridge	-	Repair Reserves	(\$100,000)	Bridge CIP	maintain revenue
1	23/24	Bridge	Lift Span Rack Pinion Shafts, Couplings, Keys	\$250,000	Bridge	-	Repair Reserves	(\$250,000)	Bridge CIP	maintain revenue
1	23/24	Bridge	Embankment Slough Repairs	\$40,000	Bridge	-	Repair Reserves	(\$40,000)	Bridge CIP	maintain revenue
1	23/24	Bridge	Deck Welding	\$60,000	Bridge	-	Repair Reserves	(\$60,000)	Bridge CIP	maintain revenue
2	24/25	Bridge	Clean and reset bearings (4yr cycle)	\$20,000	Bridge	-	Repair Reserves	(\$20,000)	Bridge CIP	maintain revenue
2	24/25	Bridge	ETC Hardware Warranty/System Updates	\$127,000	Bridge	-	Repair Reserves	(\$127,000)	Bridge CIP	maintain revenue
2	24/25	Bridge	Replace bolts & guard rails segments	\$60,000	Bridge	-	Repair Reserves	(\$60,000)	Bridge CIP	maintain revenue
2	24/25	Bridge	Channel scan at Pier Foundations	\$40,000	Bridge	-	Repair Reserves	(\$40,000)	Bridge CIP	maintain revenue
1	23/24	Marina	6(f) Research Study/Marina Basin	\$20,000	Marina	\$ 20,000.00	Bridge Grants	\$0	Bridge Replacement	Next Phase
1	23/24	Marina	Moorage Float Repair (No. C-dock, Ph. 1)	\$40,000	Marina	-	Marina Net Revenue	(\$40,000)	Bridge CIP	maintain revenue
2	24/25	Marina	Planning Study- Moorage & Upland	\$50,000	Marina	-	Marina Net Revenue	(\$50,000)	Bridge CIP	maintain revenue
2	24/25	Marina	Moorage Float Repair (No. C-dock, Ph. 2)	\$40,000	Marina	-	Marina Net Revenue	(\$40,000)	Bridge CIP	maintain revenue
2	25/26	Marina	Moorage Float Repair (No. C-dock, Ph. 3)	\$40,000	Marina	-	Marina Net Revenue	(\$40,000)	Bridge CIP	maintain revenue
3	26/27	Marina	Moorage Float Repair (No. A/B dock)	\$40,000	Marina	-	Marina Net Revenue	(\$40,000)	Bridge CIP	maintain revenue
3	27/28	Marina	Rehabilitate transient dock	\$400,000	Marina	-	Marina Net Revenue	(\$400,000)	Bridge CIP	maintain revenue
3	27/28	Marina	Restore/Expand South basin dock	\$600,000	Marina	-	Marina Net Revenue	(\$600,000)	Bridge CIP	maintain revenue
3	29/30	Marina	Construct Dinghy launch ramp & dock	\$550,000	Marina	-	Marina Net Revenue	(\$550,000)	Bridge CIP	maintain revenue
3	31/32	Marina	Repave Marina Way	\$50,000	Marina	-	Marina Net Revenue	(\$50,000)	Bridge CIP	maintain revenue
1	23/24	Real Estate Existing	Replace N. Facing Windows - Jensen	\$80,000	Real Estate Existing	-	Industrial Net Rev	(\$80,000)	Building CIP	maintain revenue
1	23/24	Real Estate Existing	Building Assessment Report - All Buildings	\$50,000	Real Estate Existing	-	Industrial Net Rev	(\$50,000)	Building CIP	maintain revenue
2	24/25	Real Estate Existing	Enviro Survey of breezeway - Jensen	\$10,000	Real Estate Existing	-	Industrial Net Rev	(\$10,000)	Building CIP	maintain revenue
2	24/25	Real Estate Existing	Roof Repair / Replace - Jensen	\$1,000,000	Real Estate Existing	-	Industrial Net Rev	(\$1,000,000)	Building CIP	maintain revenue
2	24/25	Real Estate Existing	Elevator Maintenance - Wasco	\$50,000	Real Estate Existing	-	Industrial Net Rev	(\$50,000)	Building CIP	maintain revenue
3	25/26	Real Estate Existing	Retaining Wall - ADD Parking - Big 7	\$35,000	Real Estate Existing	-	Industrial Net Rev	(\$35,000)	Building CIP	maintain revenue
3	25/26	Real Estate Existing	Elevator-Hydraulic Modernization - Big 7	\$150,000	Real Estate Existing	-	Industrial Net Rev	(\$150,000)	Building CIP	maintain revenue
1	23/24	Real Estate Undeveloped	Market Analysis Study - Lower Mill	\$50,000	Real Estate Undeveloped	\$ 50,000.00	Industrial Net Rev	\$0	2022 Goal Setting	Next Phase
1	23/24	Real Estate Undeveloped	Wetland Infill Project - Lower Mill	\$250,000	Real Estate Undeveloped	-	Industrial Net Rev	(\$250,000)	CIP	Next Phase
1	23/24	Real Estate Undeveloped	Port Office Relocation Study	\$50,000	Real Estate Undeveloped	\$ 50,000.00	Bridge Grants	\$0	Bridge Replacement	n/a
2	24/25	Real Estate Undeveloped	Build Industrial Building - Lower Mill	\$10,000,000	Real Estate Undeveloped	-	Bridge Grants	\$0	Bridge Replacement	n/a
2	24/25	Real Estate Undeveloped	Lot 1 Phase 1: Anchor Way/First St. AE/Design	\$950,000	Real Estate Undeveloped	-	Bridge Grants	\$0	Bridge Replacement	n/a
3	26/27	Real Estate Undeveloped	Acquire Industrial Property	\$15,000,000	Real Estate Undeveloped	-	Bridge Grants	\$0	Bridge Replacement	n/a
1	23/24	Waterfront	Nichols Tree Replacement Project	\$20,000	Waterfront	\$ 20,000.00	Grant TBD	\$0	staff inspection	n/a
2	24/25	Waterfront	Event Site Dock - safety resize	\$45,000	Waterfront	-	Grant TBD	\$0	staff inspection	n/a
2	24/25	Waterfront	Marina Beach Signage (x 2)	\$30,000	Waterfront	-	Grant TBD	\$0	staff inspection	n/a
2	24/25	Waterfront	Nichols Seawall - Pavement Repair	\$100,000	Waterfront	-	Grant TBD	\$0	staff inspection	n/a
2	24/25	Waterfront	Event Site Landscaping	\$20,000	Waterfront	-	Grant TBD	\$0	staff inspection	n/a
2	24/25	Waterfront	Event Site Restroom Rehab	\$20,000	Waterfront	-	Grant TBD	\$0	staff inspection	n/a
2	24/25	Waterfront	Nichols Tree Replacement Project	\$20,000	Waterfront	-	Grant TBD	\$0	staff inspection	n/a
2	25/26	Waterfront	Event Site Landscaping	\$20,000	Waterfront	-	Grant TBD	\$0	staff inspection	n/a
3	27/28	Waterfront	Event Site Landscaping	\$30,000	Waterfront	-	Grant TBD	\$0	staff inspection	n/a
1	23/24	Waterfront/Recreation	Trail - Paving repairs	\$10,000	Waterfront/Recreation	-	WF Rec Net Rev	(\$10,000)	staff inspection	n/a
2	24/25	Waterfront/Recreation	LED Lighting HR Footbridge	\$65,000	Waterfront/Recreation	-	WF Rec Net Rev	(\$65,000)	staff inspection	n/a
2	24/25	Waterfront/Recreation	Footbridge Deck replacement	\$30,000	Waterfront/Recreation	-	WF Rec Net Rev	(\$30,000)	staff inspection	n/a

Capital Projects For FY 23-24

This page intentionally left blank.





# Columbia Gorge Economic Indicators

## February 2023 Data

### Local Area Unemployment Rates (Seasonally adjusted)

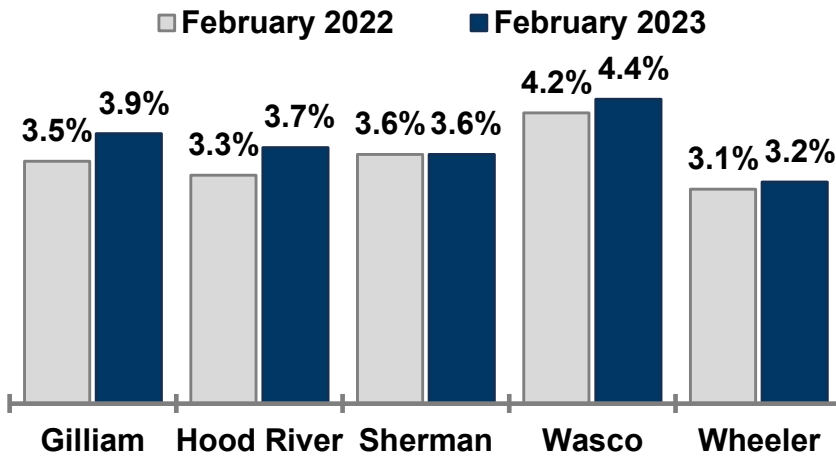

### Graph of the Month (select Oregon counties)

#### Workers Claiming Unemployment Benefits

Source: Oregon Employment Department and U.S. Bureau of Labor Statistics

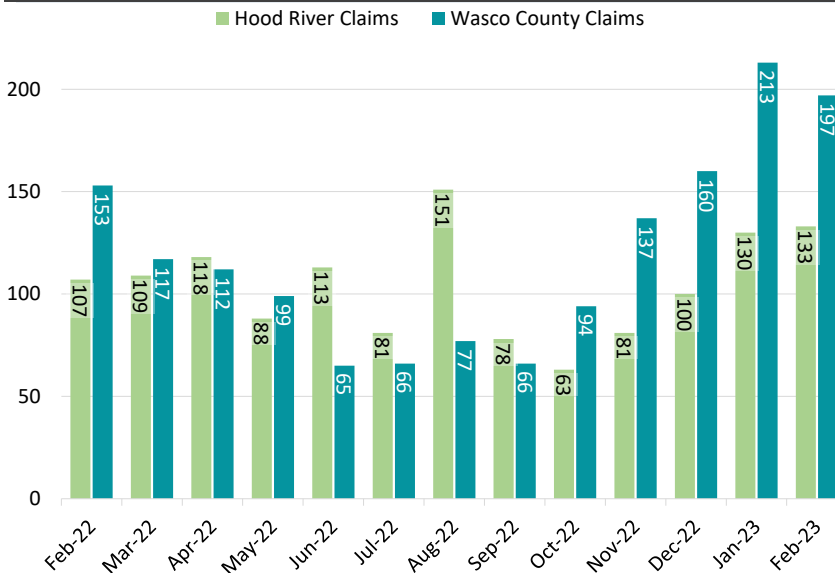

The number of insured unemployed workers filing for Unemployment Insurance (UI) in Wasco County decreased in February (-16). This is the first over the month decline since September 2022, when claims began to trend upward. Year-over-year claims, however, are up by 44.

Hood River County saw continued claims go up slightly (+3) from January to February of this year. Similarly, over the year claims were up by 26. Claims have been trending upward since hitting a recent low of 63 in October 2022. This coincides with the rise in the unemployment rate, which began to trend upward in October.

### Select Industry Gains and Losses (Over-the-year net employment change)

#### Hood River County

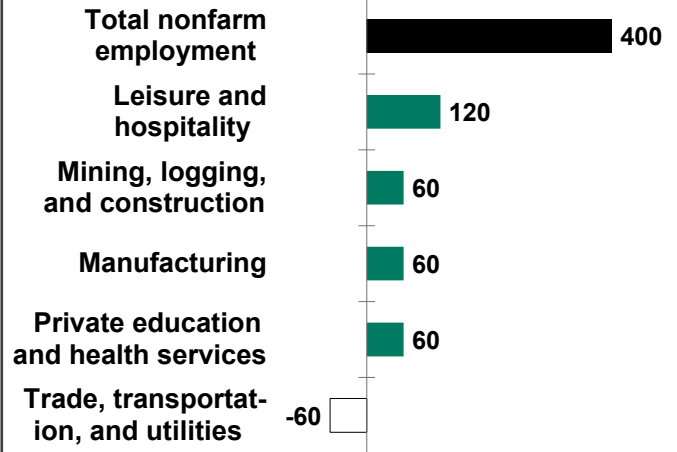

#### Wasco County

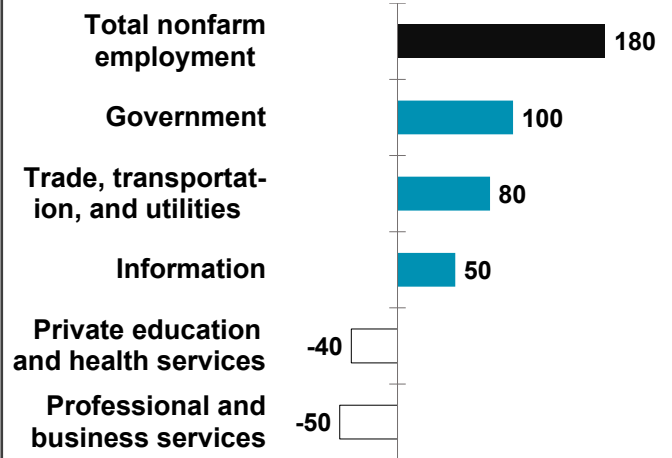

### Notable Over-the-Year Changes

#### Gilliam

**Total nonfarm employment (+150)**  
Private education and health services (+10)  
Government (-5)

#### Sherman

**Total nonfarm employment (+55)**  
Trade, transportation and utilities (+25)  
Leisure and hospitality (+15)

#### Wheeler

**Total nonfarm employment (+15)**  
Leisure and hospitality (+5)  
Trade, transportation and utilities (-5)

Want to join the distribution list? Contact:  
Nicole Ramos at [Nicole.S.Ramos@employ.oregon.gov](mailto:Nicole.S.Ramos@employ.oregon.gov)

This page intentionally left blank.



April 4, 2023

Kevin Greenwood  
Port of Hood River  
1000 East Port Marina Dr.  
Hood River, OR 97031

Dear Kevin,

I am pleased to present the 2023 Mid-Columbia Economic Development District (MCEDD) Comprehensive Economic Development Strategy (CEDS) project ranking, which includes your project(s). The MCEDD Board met in March to finalize prioritization of regional projects based on lists submitted through county economic developers.

The MCEDD Board and staff reviewed all the information you provided and prioritized the list based on the project's economic impact, regional impact, readiness to proceed, need for the project, level of local funding available and level of local capacity. The list of top ten priorities for both Oregon and Washington are enclosed with this letter. In addition, the Board voted to include all projects listed on the county priority lists in the CEDS update.

A full project list, including your submission(s), will therefore be incorporated into the 2023 Comprehensive Economic Development Strategy which can be cited to show local support when seeking grants and loans.

Thank you again for participating in this process. If you have any questions about the Comprehensive Economic Development Strategy or project ranking you are welcome to contact me at 541-296-2266 or [jessica@mcedd.org](mailto:jessica@mcedd.org).

Sincerely,

A handwritten signature in blue ink that reads "Jessica Metta".

Jessica Metta  
Executive Director



## 2023 Regional Priority Rank (Oregon) - DRAFT

Rank	Sponsor	Project	Reasoning
1	Ports of Cascade Locks, Hood River, and Klickitat, Klickitat County, Cities of Bingen and White Salmon	<p><b>Interstate Bridges</b>  Port of Hood River Hood River-White Salmon Interstate Bridge Replacement: The existing bridge is nearly 100 years old, structurally obsolete and seismically deficient. A new bridge is needed to improve and ensure multi-modal transportation of people and goods across the Columbia River between the communities of Bingen and White Salmon in Washington, and Hood River in Oregon. Total project cost estimate: \$520M. Approximately \$450 million in State and Federal grants will be needed. Balance from local tolls.  Port of Cascade Locks Bridge of the Gods Strengthening and Safety Improvements: Maintenance of the Bridge of the Gods and improvements to include 1) Seismic Strengthening of the Bridge (\$12M) and 2) Additional Bridge resiliency and safety measures including a safe pathway for pedestrian and bicyclist needs (\$70M).</p>	<p>Core transportation connection. Resilience issue. Impact to key industry sectors.</p>
2	Hood River, Sherman, and Wasco Counties, City of Hood River	<p><b>Housing</b>  Hood River: Development of the 780 Rand Road Housing Development project for affordable housing as well as additional land acquisition for affordable and attainable housing development in the City of Hood River and Hood River County. Total project cost estimate: \$54M. Estimated amount of funds still needed is \$51M (will apply for \$17.6M in LIHT funds; \$18M in LIHTC in 2023).  Sherman: The housing stock in Sherman County is lacking the quantity and quality necessary for new employees to find a place to live in the County. Sherman County has created four incentive programs to encourage the construction of new housing or the rehabilitation of existing housing. The County continues to look for creative ideas that would solve the housing issues.  Wasco: Housing prices have continued to be unaffordable for many in Wasco County and supply is not meeting current needs. This has hindered employees seeking to come to Wasco County have hindered businesses' ability to grow. Better understanding this need and supporting community partners in opportunities to address it will impact access to a robust workforce moving forward.</p>	<p>Addressing housing constraints is a priority strategy for the CEDS</p>
3	Columbia Gorge Community College	<p><b>Columbia Gorge Childcare Center (CGCC)</b>  There continues to be a serious shortage of qualified childcare. CGCC completed a feasibility study as the first step in developing a public childcare center and to improve workforce training available to childcare providers. CGCC is working with local partners for both potential locations and ongoing engagement. They are also increasing the size of the proposed center to 200 slots to reduce the subsidy needed based on economies of scale. CGCC has approximately \$1.75 million in ARPA funds allocated by the State for this project and will likely seek additional resources if the project is able to move forward.</p>	<p>Childcare needs (costs, lack of access) is a priority strategy in the CEDS. Addresses support for workforce participation.</p>
4	Sherman and Wasco Counties, Q-Life	<p><b>Broadband</b>  Sherman: The County has completed fiber to the home in the cities and connected each community to a fiber backbone. The County has also purchased four solar-powered trailers with mounted repeating antennas that can pick up the signal from wireless towers and redirect the signal to homes that are not in the direct line of those towers. They would like to continue this project into more areas to reach those hardest to serve.  Q-Life and Wasco County: Q-Life is working to clearly identify gaps in broadband service availability for communities across Wasco County, develop strategies to address key areas, and preparing for funding resources at the State and Federal levels. Additionally, Q-life is developing an improved colocation facility in The Dalles where providers and emergency communications networks can meet and access scalable communication paths. They completed initial designs for the facility with a cost estimate of approximately \$1 million. Additionally, Q-Life is working to ensure that communities across the County are connected via fiber to support strong last mile connection opportunities.</p>	<p>Broadband is a key infrastructure need outlined in the CEDS. Regional in nature. Adds resiliency to the region.</p>

**2023 Regional Priority Rank (Oregon) - DRAFT**

5	City of Hood River	<p><b>Hood River Elevated Sewer Line</b> The existing elevated sewer main on the south side of the interstate is very old, exposed and there is no means to divert or stop the flow if there is a break on the main, with potentially catastrophic environmental costs. This project will install a lift station and re-route the sewer line. Total project cost estimate: \$6.7M with \$6.4M still needed.</p>	Water/wastewater is a key infrastructure need outlined in the CEDS. Addresses key business needs. Adds resiliency to the region.
6	City of The Dalles, Klickitat County, CGCC	<p><b>Aviation Maintenance Training Hangar and Industrial Park Development</b> City of The Dalles and Klickitat County are co-applicants for a successful \$2.8 million EDA funding request to match a \$700,000 local commitment to support college training program hangar and industrial park development at Columbia Gorge Regional Airport. Cost escalation since EDA proposal was submitted two and a half years ago has resulted in a projected shortfall of \$1.9 million however. Klickitat County is seeking \$500,000 grant from Washington State Department of Commerce and the City of The Dalles submitted a congressionally directed spending request for additional resources to close the gap on this project.</p>	Addresses opportunities for key industry sectors, encourages development in an economically distressed area, opportunity for job creation.
7	City of Grass Valley	<p><b>Waste Water Project</b> The City of Grass Valley is researching construction of a municipal waste water system. The council hired an engineer to do a feasibility study in 2021 and that study is complete and has been presented to the community for feedback. The City had a One Stop meeting in 2022 and learned that the CWSRF program will be increasing its maximum forgivable loan amount. The City is waiting to hear details of the program changes (expected in early 2023) before proceeding with any funding applications. The City submitted a FY24 Congressionally Directed Spending Request for a portion of project costs. Estimated project cost is \$6 million.</p>	Water/wastewater is a key infrastructure need outlined in the CEDS. Opens opportunities for development. Adds resiliency to the region.
8	Port of Cascade Locks	<p><b>Business Park Infrastructure Development</b> Development of roads and other infrastructure related to commercial developments. Total cost: \$3 million.</p>	Addresses opportunities for key industry sectors.
9	Port of Hood River	<p><b>Lot 1</b> Lot 1 is the largest remaining light industrial property in Hood River. A significant infrastructure investment- specifically, water, sewer, and public streets - is necessary to prepare the site for industrial development to meet long term job creation and economic development goals of the community. Total project cost estimate: \$4,800,000.</p>	Addresses opportunities for key industry sectors.
10	City of Rufus	<p><b>Well #3 Feasibility Study &amp; Upgrades</b> Primary well underperforming for years even with consistent maintenance. The City is unsure about water levels or future capabilities of the well, so will be seeking funding to do further investigations and repair, if feasible, or for drilling a new well.</p>	Water/wastewater is a key infrastructure need outlined in the CEDS. Adds resiliency to the region.

## Genevieve Scholl

---

**From:** Kevin Greenwood  
**Sent:** Friday, April 14, 2023 3:47 PM  
**To:** Genevieve Scholl  
**Subject:** FW: usage report  
**Attachments:** Port of Hood River.pdf

Kevin  
(541) 961-9517: cell  
(541) 386-1138: direct

**From:** Lindsay Schuelke <lindsays@forthmobility.org>  
**Sent:** Monday, March 27, 2023 1:14 PM  
**To:** Kevin Greenwood <kgreenwood@portofhoodriver.com>  
**Cc:** Genevieve Scholl <gscholl@portofhoodriver.com>; Kelly Yearick <kellyy@forthmobility.org>  
**Subject:** Re: usage report

Hi Kevin and Genevieve,

Sorry for the delay on this! I've been hoping for our research partner to pair this data alongside energy data for all the sites "to-date" in the project term, but I heard recently that we'll be receiving that analysis in April. Happy to share the hard data. Some additional points:

- The cars were replaced in late March 2022, so the Leafs were in place in April 2022 for their first full month. The Port car was also upgraded to a Chevy Bolt in early February this year due to lucky circumstances Envoy offered that to us.
- Booking Revenue - The rate changed in November 2022 from \$8/hr to \$5/hr - though we have implemented driving credits as part of our promotional work
- Booking Count - pretty straightforward, you see that when the Honda Clarities were in place there wasn't activity. We were dealing with a lot of tech challenges with the 12V batteries dying, at a frequency we learned was quite consistent. When that occurred, the car had to be put "offline" and jumped/battery replaced. The Port vehicle had the misfortune of having this occur more than any other car. We were not made aware of every occurrence but were given this information on it in February:
- Envoy 699 Nissan Leaf
  - April 18, 2022 - Dead 12v
  - June 13, 2022 - Dead 12v
  - June 27, 2022 - Low 12v
  - July 1, 2022 - Dead 12v
  - August 1, 2022 - Dead 12v
  - October 6, 2022 - Low 12v
  - October 17, 2022 - Dead 12v
  - October 25, 2022 - Dead 12v
  - November 3, 2022 - Dead 12v
  - December 16, 2022 - Low/dead 12v
  - January 15, 2023 - Low/dead 12v
  - January 19, 2023 - Dead 12v
  - January 26, 2023 - Low 12v

- A total of 13 instances. It's admittedly been a chicken and egg trying to increase utilization while cars are down so often. However, the membership and utilization increase we're seeing across all sites since the car swaps is an improvement.
- Users - Envoy has a bit of a confusing system for identifying users. The total active users column shows how many different people were using the cars at the site. The Active Users shows the number of people using the car corresponding to bookings data - so as you see for example, one person has booked the Port car four times in Jan and Feb this year.

I hope this is helpful. We've certainly experienced a difficult start in this project with a COVID rollout and tech problems. The prior 2018 Honda Clarities were donated to the project, but were a "gift like a puppy" trying to use them on the Envoy platform. In full transparency, we're in the position currently of thinking about how to continue to refine what the carshare looks like in Hood River including the platform partner and that is under strong consideration.

Per the surveys and conversations with members, we have gotten positive feedback about the cars, including about the upgraded Leafs. We know they've taken longer trips and that membership + utilization are growing. We were stuck at about 20 members prior to the swaps, and now are at 58.

I've looped in Kelly to this thread as well. We really value the Port's involvement in this effort and want to continue on in a way that makes the most sense for the Hood River community. We're in conversations currently with more local partners including CAT and The Next Door Inc. We'd like to involve more local partners in another rendition to move forward as we pursue funding opportunities. Let me know if you have any questions or ideas!

Thank you,  
Lindsay

On Fri, Mar 17, 2023 at 3:28 PM Kevin Greenwood <[kgreenwood@portofhoodriver.com](mailto:kgreenwood@portofhoodriver.com)> wrote:

Hello Lindsay,

I was wondering if it would be possible to get usage reports for the car located on Port property? Thank you,

Kevin Greenwood, Executive Director

PORT OF HOOD RIVER

1000 E. Port Marina Dr.

Hood River, OR 97031

(541) 386-1138: direct

(541) 961-9517: cell



Property		Program		Account		Booking Type		Booking Status		Date
Port of Hood River		All		All		All		All		6/15/2017 2/28/2023
Year	Booking Revenue	Revenue Share	Booking Count	Year	Active Users	Total Active Users	Registered Users	Total Registered Users		
2023	\$15.00	\$7.50	4	2023	1	12	6	48		
February	\$15.00	\$7.50	2	February	1	12	2	48		
January	\$0.00	\$0.00	2	January	1	12	4	46		
2022	\$142.90	\$71.45	33	2022	11	11	35	42		
December	\$0.00	\$0.00	0	December	0	11	1	42		
November	\$20.00	\$10.00	6	November	3	11	3	41		
October	\$10.90	\$5.45	5	October	3	11	2	38		
September	\$24.00	\$12.00	4	September	2	9	4	36		
August	\$0.00	\$0.00	8	August	3	8	4	32		
July	\$64.00	\$32.00	7	July	3	6	7	28		
June	\$0.00	\$0.00	1	June	1	3	2	21		
May	\$24.00	\$12.00	2	May	2	2	5	19		
April	\$0.00	\$0.00	0	April	0	0	7	14		
March	\$0.00	\$0.00	0	March	0	0	0	7		
February	\$0.00	\$0.00	0	February	0	0	0	7		
January	\$0.00	\$0.00	0	January	0	0	0	7		
2021	\$0.00	\$0.00	0	2021	0	0	0	7		
December	\$0.00	\$0.00	0	December	0	0	0	7		
November	\$0.00	\$0.00	0	November	0	0	0	7		
October	\$0.00	\$0.00	0	October	0	0	0	7		
September	\$0.00	\$0.00	0	September	0	0	0	7		
August	\$0.00	\$0.00	0	August	0	0	0	7		
July	\$0.00	\$0.00	0	July	0	0	4	7		
<b>Total</b>	<b>\$157.90</b>	<b>\$78.95</b>	<b>37</b>	<b>Total</b>	<b>12</b>	<b>12</b>	<b>48</b>	<b>48</b>		

This page intentionally left blank.



March 29, 2023

Port of Hood River Commissioners and Staff,

The Hood River Outrigger Canoe Club board and all of its members wish to extend a warm Aloha and a sincere Mahalo for all the support the Port has provided to the Hood River Outrigger Canoe Club (HROCC) over these past nine years. As the Port continues to move forward with its five-year plan and bridge replacement plan we would like to take this opportunity to share some of our accomplishments and our future goals for our club.

Over the past nine years our club has grown from a small group of less than 30 members and one Canoe to over 130 members and 6 canoes in 2022. Part of this has been fueled by the phenomenal growth of outrigger canoe paddling in the US; a trend that has migrated from Hawaii to the continental U.S. The outlook for this sport continues to be extremely strong with participation from the West Coast through the Midwest onto the East Coast and internationally..

But an equally important factor in the growth of our club has been the extraordinary enthusiasm, dedication and knowledge of our Founders, Board of Directors, ongoing members and the residents of the Gorge who have extended their welcome and experience to all people who have an interest in participating in this awesome activity!

Several years ago HROCC began a very competitive race program. Last year we competed in most of the Northwest Regional races but also sent teams to Kona, Hawaii to compete against stellar fields of international racers. Hood River was fortunate to bring home many race awards against these incredible competitors.

With the ongoing dedication of our club volunteers we continue to improve and offer our Junior Program known as Keikis. Working with Fiona Wylde of Wylde Wind & Water, Hood River County Opportunity Connections and Hood River Middle School we helped more than 150 Keikis get introduced to paddling and get on the water in 2022. As of the date of this letter we are making plans to host even more in 2023. The curriculum included:

- Basic paddling skills (it's difficult to get 6 kids in a boat paddling in sync!),
- Water safety including how to right a boat that has HULI (i.e. flipped),
- Hawaiian culture, which is the rich history of Outrigger Canoeing as a family endeavor known as Ohana, and most important, having fun!

Many of our members, ranging in age from 16 to 80+, just enjoy paddling with HROCC for the sense of camaraderie, health and fitness. HROCC has had a thorough beginners introductory program since its inception which is designed to quickly, and safely bring the uninitiated paddler up to speed.

You will also often see many of our race teams, of various ages, practicing for races in the unique and challenging environment that we share here in the Gorge. The last day of our 2022 paddling season we had a record number of 48 paddlers in 8 boats on the water. It was a beautiful experience!!

In 2022, with a grant award from She Flies, we were able to directly reach 11 women and indirectly reach approximately 75 women through our She-Seat-Six program where in women participants took on the steering role during HROCC paddling events and practices. She-Seat-Six participants reported greater confidence in windy condition turns and huli recoveries, as well as enhanced skills in commanding a huli recovery, and standardization of seat roles and communication norms during a huli recovery. These women also openly reported reductions in fear and anxiety around remounts and assists, how to support weak swimmers, responses to getting caught in skirts/zipper related fears, and fears related to swamping the boats. All participants reported progression on these skills and that the confidence gained from the repetition of the drills in “spooky” conditions was incredibly helpful and fear reducing. Results to date included:

- 11 women, who are now competent at OC-6 windy remounts, commanding windy huli recoveries, crew member assists, and basic emergency response procedures.
- Massive gains in standardization of boat recovery communications, confidence, reductions in personal fears, and familiarity with steering and safe recovery practice in windy conditions.

The She Flies grant money supported the cost of the jet ski safety staffing. This was such an important part of the program’s success. Our safety hire came with several years of water related safety training and experience, and a very calm, supportive demeanor. Eye contact, and knowing and seeing the jet ski nearby was an incredible confidence boost as they practiced the skill set over and over, with different configurations of women. Our safety hire also generously took a lot of photos and video documented many of our drills and steering.

2023 includes plans for future growth and sustainability of the project: We have several women ready for next steps in their skill progression. This progression entails steering and Huli-ing in bigger water, earlier in the season when water and air temperatures are colder, “in the channel,” and without the safety ski present. Growing a strong network of women is a large part of our plan to sustain the program, integrate these important activities into regular club activities. assure the ongoing vitality of HROCC and to keep as many members on the water as possible.

As plans for the Basin, 1st Street and Lot 1 progress it is critical that HROCC and the port continue to discuss a long-term location for the HROCC Hale. The three canoes that currently reside at Frog's Beach during our paddling season weigh approximately 400 lbs. apiece and are 45 feet long. Realistically, to be able to get them to the water requires a great deal of muscle power and technique that would not be possible if they were located further away.

The canoes in our current leased Hale location are newer and much more expensive carbon fiber which are more easily moved but must be protected because of their light weight from the famously raging winds in the Hood River Gorge. The Hale also acts as our team gathering location as we host Ohana gatherings. These gatherings are designed to build our community as we invite members and non-members to partake in our Ohana pot-luck celebrations.

Despite keeping our club dues at a reasonable rate we have judiciously managed our finances and have been able to dedicate a specific fund for the purpose of building a more permanent Hale (i.e clubhouse) in the future. In 2023 we have put together a "working group" of members to help actively find a permanent facility location. We sincerely hope that as the Port continues its plans to develop the waterfront that HROCC is given the opportunity to discuss, find and eventually enter into a more long-term agreement and build a permanent facility in keeping with the overall use and esthetics of our beautiful Hood River Waterfront area.

Mahalo,  
Hood River Outrigger Canoe Club Board of Directors

*Sherry Bohn, President*  
*Janet Whittick, President Elect*  
*Lura Lee, Treasurer*  
*Suz Burd, Secretary*  
*Patrick Harrington, Sergeants at Arm*  
*Peny Wallace, Member at Large*

This page intentionally left blank.

**Airport Activity:**

March was a great month for flight operations. Weather conditions allowed for an increase in operations from last month. Next month should show a continued increase in flight operations.

Aircraft Operations

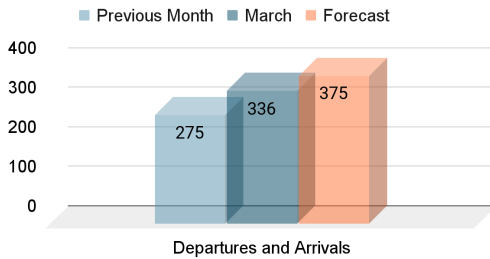

**Night Flights:**

2 commercial night flights were conducted in March. Anticipate minimal R&D flights throughout April as conditions permit. No large night events scheduled.

Night Events

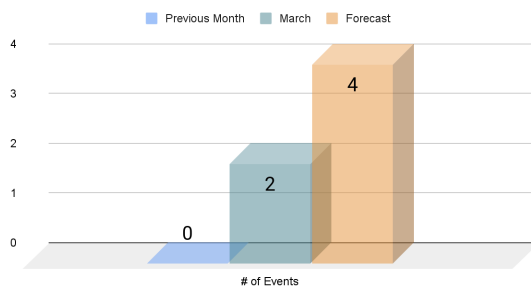

**Flight Training:** Hood Aero conducted 5 training events in March. Most events were intro to flying events and short duration endorsement events. Walk in traffic to the requesting flight training in the FBO has been increasing. Anticipate this trend to continue throughout the

Spring.

Flight Training Events

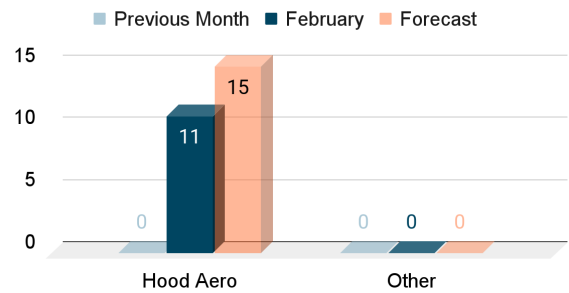

**Maintenance Activity:**

March was a slow month in terms of the number of completed maintenance events. This is due, in part, to several large maintenance events currently being conducted. Anticipate an increase in maintenance activity in April as these larger projects complete.

Maintenance Events

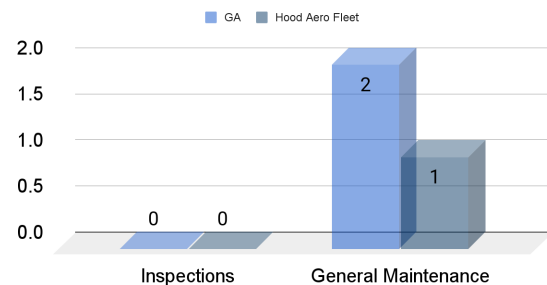

**Fuel Sales:** March fuel sales reached a level close to what was predicted. Anticipate a slight rise in sales in April.

**Fuel Sales (Gallons)**

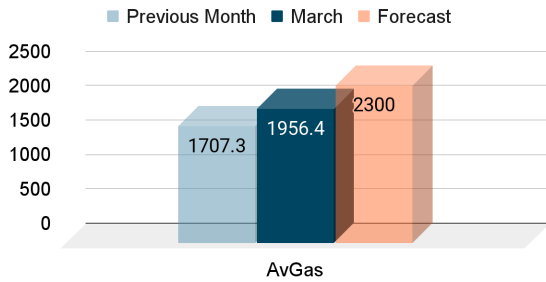

**Fuel Flowage Fees:**

The new fuel tank has been placed at 4S2 and plumbed. Awaiting electrical hookups. When complete and online, the tank will be filled and flowage fees will begin.

**Tie Down Activity:**

- 23 total spots.
- 57% utilization for March averaged.
- \$70.00 collected in March.

**Tie Down Utilization**

- Available Tie Downs
- Rented Tie Downs Long Term

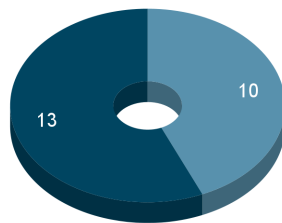

**Noise Feedback:**

No noise complaints taken by the FBO in March.

**Pilot Feedback:**

No pilot feedback was supplied to the FBO in March.

**Airport Surfaces:**

	Condition	Notes.
Rwy 7/25		
Grass Strip		
N. Ramp		
S. Ramp		
S. Gravel		
Taxiways		

**Facilities:**

	Condition	Notes.
N. Hangars		
S. Hangars		
FBO		
MX Hangar		
Ops Hangar		
Collins Hangar		
Blue Hangar		

**Lighting:**

- No issues noted with airport

**Other:**

- No other issues noted.



# Commission Memo



Prepared by: Daryl Stafford  
Date: April 18, 2023  
Re: Ordinance 27 Regulating Conduct on  
Port Property adoption

---

As activity along the waterfront changes over time there is a periodic need to consider updates to ordinances which govern and regulate conduct on Port property. An assessment of the Port's recreational sites is conducted every year as part of the annual budget process which serves as the basis for near-term decisions about capital and capital maintenance expenditures, as well as policies and changes to ordinances.

The property ordinance was last modified via Ord. 26 and adopted on June 26, 2018. The Commission discussed updates to Ord. 26 during Fall Planning December 2021 and during several Commission meetings since that time, directing staff to work with Legal to address the following key issues:

1. Animal Control
2. Overnight camping on Port property
3. Towing vehicles or trailers on Port property
4. Trespass violations/exclusion on Port property

Staff have collaborated with the Port's previous and current legal teams to delve into addressing policies, procedures, and the needed updates to Ord. 26 to legally handle these issues.

Kristen & Joanna have prepared a memo to explain more about the proposed changes and have drafted a proposed update of Ord. 26 for Commission review.

An Ordinance is being used to establish this policy since there direct penalties potentially to the public. As such ORS 198 requires that the Ordinance be read at two meetings. The board may direct that the reading be by title only. Minor adjustments/edits may occur between readings and acknowledged before adoption.

**RECOMMENDATION:** Motion to conduct the first reading and to read Ordinance 27 regulating conduct on Port property by title only.

President Sheppard would call for a second and then a voice vote. After approval, Daryl can read the title of the Ordinance into the record. A similar action item will be on the May 2<sup>nd</sup> agenda and the Ordinance goes into effect June 2, 2023.

-###-





CAMPBELL PHILLIPS PC  
Attorneys at Law

## MEMORANDUM

To: Board of Port of Hood River Commissioners  
From: Joanna Lyons Antley & Kristen Campbell, Campbell Phillips PC  
Date: April 12, 2023  
RE: Ordinance 24 and Exclusion Policy

In 2018, your Board approved an amendment to Ordinance 24, regulating conduct on Port Property.

Since this time, the state of Oregon enacted HB 3115, that requires any city or county law regulating the acts of sitting, lying, sleeping or keeping warm and dry outside on public property must be “objectively reasonable” based on the totality of the circumstances as applied to all stakeholders, including persons experiencing homelessness. Although the Port is not a city or county regulated by HB 3115, a court could decide that Port is subject to the same restrictions.

Counsel proposes a different approach – excluding persons from Port property who do not follow the Port’s conduct rules without regard to whether the person is homeless, including but no limited to, no overnight camping and all dogs must be on a leash and under control.

Oregon Courts have upheld the right to regulate public property for the general purposes for which the property is used. *State v. Carr*, 215 Or App 306 (2007). A person may be directed not to enter public property for misconduct as long as that person is given the right to due process, which would include a notice and the right to request a hearing. *State v. Koenig*, 238 Or App at 308-310. Pursuant to the proposed revised ordinance, once a person in violation of applicable Port policy is directed not to enter onto Port property, if the person remains or returns, the person will be cited for trespass by the City of Hood River.

The proposed exclusion policy and procedure will be considered at a future Board meeting but is included here for insight into enforcement. The proposed exclusion policy will enact a procedure for individuals that violate Port ordinances or criminal law. The exclusion policy will state the following: (1) exclusion will be for no more than 6 months; (2) certain positions are designated as “in charge” of the Port properties and have the power to issue notice to exclude individuals; (3) notice will be served personally or by mail, and (4) excluded individuals will be given the right to request a hearing.

In addition, due to the changes in parking payments and enforcement, counsel recommends revising Ordinance 24 to allow the Board to adopt a Policy and Procedure for parking fees and enforcement.

Counsel spoke to the Hood River City Attorney Dan Kearns and Hood River Police Chief Holste. Both were positive about supporting the Port of Hood River and Chief Holste was willing to cite those persons who were directed to leave Port Property.

For these reasons, counsel recommends revising Ordinance 24 to allow the Board to adopt an exclusion policy and procedure to exclude individuals who violate the Port Ordinances. At the second reading and adoption of the proposed Ordinance, your Board would consider the proposed exclusion policy and procedure.

The proposed Ordinance No. 27, a strikeout and clean copy, and the proposed Board Exclusion Policy and Procedure are attached for reference.

***It is the requested action for the Board to move to conduct a first reading of Ordinance Number 27, regulating conduct on Port property.***

**ORDINANCE NO.**  
**—2724-2018**  
**AN ORDINANCE REGULATING CONDUCT ON PORT PROPERTY AND**  
**REPEALING ORDINANCE NO. 24**

The Port of Hood River ordains as follows:

WHEREAS, the Port of Hood River desires to amend Ordinance Number 24 to update the Ordinance to allow persons designated by the Port of Hood River Board of Commissioners to exclude persons violating this Ordinance and/or criminal law from the Port's recreational properties;

WHEREAS, the Port of Hood River desires to amend Ordinance Number 24 to repeal the current parking regulations and to state that the Board will adopt a separate Board Policy and Procedure for Parking; AND NOW, THEREFORE, THE PORT OF HOOD RIVER ORDAINS AS FOLLOWS:

**SECTION 1. Scope of Ordinance.** This ordinance regulates conduct on Port ~~Property~~Property, including at Port structures.

**SECTION 2. Definitions.** Unless the context requires otherwise, for purposes of this ordinance the following definitions and provisions stated in a definition apply:

~~"Board" means Port of Hood River Board of Commissioners.~~

**"Boat Launch"** means the concrete ramp on the east side of the Marina Boat Basin.

**"Camp"** means erecting a tent or shelter, arranging bedding or occupying a parked ~~Vehicle~~vehicle, trailer or camper for purposes of, or in such a way as will permit, sleeping or remaining Overnight.

**"Commercial Activity"** means any activity directed to the general public or between two or more persons or entities undertaken for profit or personal gain.

**"Courtesy Notice"** means a written notice delivered or sent to a person informing them that a Parking Complaint has been issued and about their payment obligation.

~~"Dock" means a wharf or platform for loading or unloading people or materials.~~

**"Event Site"** means Port Property which includes an improved ~~Vehicle~~vehicle parking area and beach access to the Columbia River, located north of Port way Avenue, west of the Nichols Basin inlet, south of the Columbia River, and east of the Jensen building.

**"Executive Director"** means the person the Board has appointed to act as the general manager of all Port operations.

~~"Jensen Building" means the Port building located west of the Event Site, north of Portway Avenue and east of the City waterfront park.~~

**"Hook"** means Port Property which includes a peninsula located west of the western terminus of Portway Avenue, east of Wells Island, north of Interstate 84, and south of the Columbia River.

**"Interstate Bridge"** means the bridge owned by the Port which crosses the Columbia River from Hood River, Oregon to Washington.

**"Kiteboarding"** means pumping/drying kites, carrying inflated kites, rigging or attaching lines, launching and landing.

~~**"Lot 1"** means the undeveloped lot east of Second Street, south of Portway Avenue, and west and south of a road leading from the north end of Portway Avenue south to Second Street.~~

**"Marina Beach"** means Port Property located east of the Hood River and north of the Marina Park.

**"Marina Boat Basin"** means the river basin located north of the Marina Green and east of the Marina Park, used for launching and moorage of boats and pontoon airplanes, with access to the Columbia River.

**"Marina Boat Basin Area"** means Port Property located west of the Interstate Bridge approach road, south of the Marina Beach, east of the Hood River and north of Interstate 84.

**"Marina Green"** means Port Property which includes a grass recreation field located south of the Marina Boat Basin and north of Interstate 84.

**"Marina Park"** means the park setting and picnic shelter located east of the Hood River and west of the Marina Boat Basin.

**"Nichols Basin"** means the river basin north of Interstate 84, which runs south to north along the western boundary of the Spit, with access to the Columbia River.

**"Official Sign"** means all signs, signals, markings, devices and placards placed, erected or provided by the Port for the purpose of guiding, directing, warning or regulating ~~Vehicle~~vehicle or boat traffic or personal conduct. An Official Sign includes a Port message appearing on or from an electronic kiosk or other electronic device which provides information.

**"Overnight"** means between 11:00 p.m. and 6:00 a.m.

**"Parking Complaint"** means a written or electronic notice demanding payment issued by the Port placed on a ~~Vehicle~~vehicle or provided to a person who has violated a ~~Pay to~~ Parking Zone parking requirement.

**"Parking Pass"** means a Port-issued parking permit that authorizes a ~~Vehicle~~vehicle which displays the Parking Pass to be parked in a designated Port parking location at times specified and on terms required by the Port. The Board or Executive Director may establish Parking Pass parking locations or requirements.

~~**"Pay to Park**~~**arking Zone"** means an area of Port Property designated as a ~~Pay to Park~~parking ~~z~~Zone described and/or depicted on a Port map or diagram, where the Port limits ~~Vehicle~~vehicle parking times and charges for ~~Vehicle~~vehicle parking at specified parking locations. These Port locations reserved for ~~Vehicle~~vehicle parking, which may be in a separate confined parking area or be shoulder spaces located adjacent to a curb along a Port access way, are not considered part of a public road or street subject to Oregon Motor Vehicle Code laws governing travel on a public road or street.

~~**"Peace Officer"** means a peace officer appointed by the Board pursuant to ORS 777.190, or a peace officer as defined in ORS 161.015.~~

**"Pedestrian Bridge"** means the bridge owned by the Port of Hood River intended for pedestrian use which crosses the Hood River from the Marina Boat Basin Area leading to the southern terminus of the Spit access road.

~~"Port" means Port of Hood River. Any action attributed to the Port by this Ordinance shall be an action by a Port employee, the Board, or their designee.~~

~~"Port Marina Building Office" means the Port headquarter building located at 1000 E. Port Marina Drive, Hood River, Oregon 97031.~~

**"Port Website"** means the official Port website, portofhoodriver.com.

~~"Port Employee" means a Port employee paid a salary by the Port, or a Port employee in a full year, full time position paid wages by the Port when working for the Port. A Port employee shall have authority to carry out acts contemplated by this ordinance, and for purposes of regulating activities on Port Property shall be a "person in charge" as defined in ORS 164.205(5).~~

**"Port Property"** means real property in Hood River County, Oregon owned or controlled by the Port, and the Interstate Bridge.

**"Port Recreational Property"** means the following areas: Event Site; Hook; Marina Beach; Marina Boat Basin Area; Marina Green; Marina Park; Nichols Basin; and Spit.

**"Portway Avenue"** means a City of Hood River ("City") street running westerly from the intersection with North Second Street and easterly from the intersection with Eighth Street, ~~and~~ Street and includes connected Port roads extending in a straight line westerly from the west end of the City street and in a straight line easterly from the east end of the City street.

**"Spit"** means Port Property, which is a peninsula located north of Interstate 84, west of the Hood River, east of the Nichols Basin and south from the Columbia River including exposed land in the Columbia River which is occasionally submerged.

**"Transient Dock"** means Port Property located west of the Boat Launch and used for temporary tie-up and limited overnight moorage.

~~"Truck" means a commercial Vehicle consisting of a cab and/or a trailer attached to or detached from the cab.~~

~~"Vehicle" means every motorized device intended to carry people.~~

~~"Vehicle Owner" means the registered owner of a Vehicle in whose name title to the Vehicle is issued, and who is entitled to possession and use of a Vehicle.~~

~~"West Jensen Parking Zone" means a Pay to Park Zone on the Jensen Building property westerly from the Jensen Building.~~

## GENERALLY APPLICABLE REGULATIONS

**SECTION 3. Commercial Activity.** No person shall engage in any Commercial Activity on Port Property without the prior approval of, and under the terms and conditions prescribed by the Port.

**SECTION 4. Littering.** No person shall litter on Port Property. For purposes of this section littering is defined as the dumping, throwing, placing, depositing or leaving, or causing to be

dumped, thrown, deposited or left any refuse of any kind or any object or substance which tends to pollute, mar or deface.

**SECTION 5. Vegetation.** No person shall remove vegetation on Port Property without written permission from the Port.

**SECTION 6. Fireworks.** No person shall ignite fireworks or similar incendiary devices of any kind on Port Property, whether legally allowed in Oregon or not unless authorized by the Port in writing.

**SECTION 7. Animal Control.** No person shall bring an animal onto Port Property, or allow an animal to be on Port Property, except when the animal is leashed and under the control of an adult, ~~provided however, (1) a dog may be off leash one hour before and after sunrise and one hour before and after sunset at the Hook and the Spit if the person with the dog complies with the provisions of the Hood River County dog control ordinance and (2) a dog may be off leash at the Hood River Parks & Recreation Department Dog Park, located west of the Sewer Treatment Plant, when the Dog Park is open to the public.~~

**SECTION 8. Animal Waste.** No person shall allow the feces of an animal in that person's care or control to remain anywhere on Port Property other than in a waste receptacle.

**SECTION 9. Launching Boats.** No person shall launch a motorized watercraft from Port Property except at the Marina Boat Basin.

**SECTION 10. Camping.** ~~No~~ Except as permitted for Marina Boat Basin tenants in Section 24, no person shall camp Overnight on Port Property or ~~camp in a Pay to Park Zone~~ Parking Zone. ~~between the hours of 9:00 p.m. and 9:00 a.m.~~

**SECTION 11. Hunting.** No person shall discharge firearms, hunt, or attempt to trap or injure an animal on Port Property.

**SECTION 12. Fires.** No person shall build or attempt to build a fire on Port Property.

**SECTION 13. Drones, Remote-Controlled Aerial Devices.**

(1) No person shall operate a remote-controlled flying or aerial device on or from Port property in a manner that violates FAA regulations governing such devices.

(2) No person shall operate a remote-controlled flying or aerial device on or from Port Property after a Port employee requests the person not do so because the Port Employee has reasonable grounds to believe that activity may conflict with or impair other permitted uses on Port Property or may pose a hazard to others.

**SECTION 14. Kiteboarding.**

(1) Location Restrictions:



No person shall launch or operate a kite, kite-board or training kite from Port Property other than at the following locations:

~~An area where the activity is~~where permitted by an Official Sign, ~~or-~~  
Marina Green and Marina Beach, except when prohibited by an Official Sign.

(2) Safety Restrictions:

No person shall launch or operate a kiteboard or training kite if the ~~from Port Property, including where permitted under subsection a. or b. of this Section after a Port employee requests the person not do so because the Port Employee has reasonable grounds to believe that activity may conflict with or impair other permitted uses on Port Property or may pose a hazard to others.~~

**SECTION 15. Vehicle Parking.**

The Port shall adopt, by resolution, a Board policy and procedure for vehicle parking in the Port's Parking Zone. The Board policy and procedure shall establish the policy and procedure for the Port's establishment and enforcement of its Parking Zones.

- ~~a. — Parking Restrictions: (1) No person shall park a Vehicle on Port Property in violation of an Official Sign or request of a Port employee. (2) No person shall park a Vehicle Overnight anywhere on Port Property unless expressly authorized by the Port. (3) No person shall park a Vehicle on Port Property where curbs are painted red.~~
- b. — ~~Pay to Park Zone Obligations: The Board or Executive Director are authorized to establish Pay to Park Zone parking requirements, including designating parking locations, parking time limits, amount payable to park at a location, and late payment charges. The operator of a Vehicle, and the Vehicle Owner who parks a Vehicle or permits a person to use the Vehicle, parked in a Pay to Park Zone, in consideration of the Port granting the right to park the Vehicle at that location, shall be required and contractually obligated: (1) to comply with all Port parking requirements posted on a Pay to Park Zone Official Sign including an electronic message on or from a Pay to Park Zone kiosk or other electronic device, including an app used for the payment of parking charges; (2) to pay when due a Pay to Park Zone charge owed for parking a Vehicle; and (3) to pay any late payment charges owed to the Port.~~
- e. — ~~Parking Passes: If a valid Parking Pass is clearly displayed on the dashboard or rearview mirror of a Vehicle which authorizes the Vehicle to be parked where the Vehicle is parked during the time the Vehicle is parked, payment of other Pay to Park Zone parking charges is not required.~~
- d. — ~~Parking Terms and Conditions: Parking charges, late payment charges and terms and conditions for parking in a Pay to Park Zone shall be established by the Executive Director or Resolution of the Port Commission.~~

**SECTION 16. Vehicle Speed.** No person shall operate a ~~Vehicle~~vehicle at a speed in excess of 15 miles per hour in the Marina Boat Basin area or at the Hook or Spit, or in excess of 25 miles per hour on other Port Property, unless an Official Sign authorizes a different maximum speedthe posted speed.

**SECTION 17. Vehicles on a Path or Off a Road.**

(1) No person shall operate a ~~Vehicle~~vehicle on any pedestrian path located on Port Property except a motorized wheelchair or device used to improve mobility for a disabled person, a Port maintenance ~~Vehicle~~vehicle and an emergency ~~Vehicle~~vehicle.

(2) No person shall drive or park a ~~Vehicle~~vehicle on Port Property off a Port road or parking area without Port permission.

**SECTION 18. Official Signs.** No person shall engage in any conduct in violation of instructions or prohibitions appearing on an Official Sign on Port Property. No person shall place a sign on Port property without permission by the Port Executive Director or their designee. Contents of an Official Sign shall be approved by the Executive Director. If an Official Sign is placed by the Port on Port Property, the contents of the sign shall be deemed approved by the Executive Director.

**SECTION 19. Use Of Port Utilities.** No person shall connect an electrical device of any kind to a Port electrical power outlet or in any other manner use or interfere with electricity or water supplied to or by the Port on Port Property.

**SECTION 20. Fees.** No person shall refuse nor neglect to pay a fee or charge established by the Board or Executive Director for use of Port Property, Port facilities or Port services, when due.

**SECTION 21. Tobacco use.** No person shall use tobacco products of any kind, including cigars, cigarettes, e-cigarettes, vape pens, snuff or chewing tobacco while on Port Property or within Port buildings or facilities.

**SECTION 22. Port Permission.** No person may violate a provision of this ordinance unless the person is given express written permission to do so at a specific time or for a specific purpose by the Board or a Port employee, or an activity is allowed by an Official Sign. Such permission shall apply only to the expressly stated time, event, or activity.

## **SITE-SPECIFIC REGULATIONS**

**SECTION 23. Boat Launch and Transient Dock.**

(1) No person shall park a ~~Vehicle~~vehicle in the Boat Launch parking lot Overnight.

(2) No person shall dock a boat under 26 feet long to the Transient Dock for more than three consecutive nights.

(3) No person shall dock a boat that is 26 feet in length or longer to the Transient Dock for more than ten consecutive nights in a 30-day period.

**SECTION 24. Marina Boat Basin.** All Marina Boat Basin tenants shall comply with the conditions of their moorage agreement and with moorage rules and regulations adopted by the Port. Unless otherwise allowed or prohibited by an Official Sign, the following activities are prohibited in the Marina Boat Basin or Marina Boat Basin Area:

- a.(1) No person shall jump or dive into, swim in, windsurf, or kiteboard in the Marina Boat Basin.
- b.(2) No person shall operate a boat, an airplane or any other type of watercraft in the Marina Boat Basin at a speed in a manner which causes a wake.
- c.(3) No person shall clean fish in the Marina Boat Basin or Marina Boat Basin Area.
- d.(4) No person shall stay on a boat or boathouse moored in the Marina Boat Basin for a period of time that violates a Port moorage rule or regulation.
- e.(5) No person shall park a ~~Vehicle~~vehicle at the Marina Boat Basin parking lot for more than three consecutive nights.
- f.(6) No parent, guardian, or person having custody or control of a child under the age of 16 years shall allow the child to be in a moored boat or boathouse in the Marina Boat Basin unaccompanied by an adult.

**SECTION 25. Marina Park.**

- a.(1) No person except a Marina ~~Boat Basin~~moorage tenant or their guest shall operate or park a ~~Vehicle~~vehicle at the Marina Park between the ~~posted hours of 10:00 p.m. and 6:00 a.m.~~
- b.(2) No person shall park a ~~Vehicle~~vehicle on Marina Green grass.

**SECTION 26. Marina Beach.** No person shall recreate or otherwise use the Marina Beach in violation of an Official Sign or request of a Port employee.

**SECTION 27. Pedestrian Bridge.** The following activities are prohibited on the Pedestrian Bridge:

- a.(1) No person shall jump or dive from the Pedestrian Bridge.
- b.(2) No person shall drive a ~~Vehicle~~vehicle on the Pedestrian Bridge, with the exception of a motorized wheelchair or device used to improve mobility for a disabled person, and Port maintenance vehicles.
- c.(3) No person shall ride a bicycle, scooter or skateboard on the Pedestrian Bridge.

**SECTION 28. Spit.** No person shall drive or park a ~~Vehicle~~vehicle on the Spit north of the designated parking area.

**SECTION 29. Event Site.** No person shall engage in an activity related to kiteboarding, wing foiling or windsurfing at the Event Site except at times and in areas designated by an Official Sign.

**SECTION 30. Event Site & Nichols Basin Structures.** No person shall jump or dive from a wharf, pier, dock or pylon at or near the Event Site or the Nichols Basin. No person shall use a dock owned by the Port located at the Event Site or in the Nichols Basin without Port permission or unless allowed by an Official Sign.

**SECTION 31. Hook.** No person shall operate or park a ~~Vehicle~~vehicle at the Hook between the hours of ~~9:00 p.m. and 5:00 a.m.~~posted or when the Hook roadway entrance gate is closed.

**SECTION 32. Interstate Bridge.** The following activities are prohibited on the Interstate Bridge:

a.~~(1)~~ (1) No person shall ride a bicycle on the Interstate Bridge.

b.~~(2)~~ (2) No person shall operate an electronic bicycle, motorized scooter or skateboard on the Interstate Bridge.

c.~~(3)~~ (3) No person shall walk onto or jump from the Interstate Bridge.

d.~~(4)~~ (4) No person shall drive a ~~Vehicle~~vehicle in excess of ~~25 miles per hour~~the posted speed on the Interstate Bridge, unless a different speed is posted at an entrance to the Interstate Bridge, in which event the driver shall obey the posted speed. Emergency Vehicles are exempt from this requirement in cases of an emergency.

e.~~(5)~~ (5) No person driving a ~~Vehicle~~vehicle shall pass another ~~Vehicle~~vehicle traveling in the same ~~direction, or~~direction or pass a ~~Vehicle~~vehicle in the same lane of travel which is stopped on the Interstate Bridge.

f.~~(6)~~ (6) No person shall stop, park, or leave a ~~Vehicle~~vehicle unattended on the Interstate Bridge.

g. ~~No person shall drive a Vehicle onto or across the Interstate Bridge without paying a bridge toll established by the Port.~~

(7)

## ENFORCEMENT

~~**SECTION 33. Severability. This ordinance shall be liberally constructed to effectuate the purposes of this ordinance. Each section, subsection or other portion of this ordinance shall be severable; the invalidity of any section, subsection, or other portion shall not invalidate the remainder.**~~

~~**SECTION 34. Enforcement of Ordinance and Parking Compliance. The following persons have the authority to carry out the provisions of this Ordinance: The following provisions apply to enforcement of violations of this ordinance:**~~

a. ~~Port employees shall have authority to carry out the provisions of this ordinance, to cause citations for ordinance violations to be issued by a Peace Officer, and if the employee is a Peace Officer to issue citations.~~

(1)

(2) All peace officers of the city, the county, the state as defined by ORS 133.005.

(3) ~~Land~~licensed private security professionals as defined in ORS chapter 181 and those appointed by the Board shall have the authority to enforce the provisions of this ordinance and to issue citations for the violation of any section of this ordinance.

(4) For Parking Zone violations, any person appointed by the Executive Director.

b. ~~Any person who is issued a citation for the violation of any section of this ordinance must appear in the Circuit Court of the State of Oregon, Hood River County or in such other court in Hood River County with jurisdiction over the matter as stated on the citation.~~

**SECTION 34. Parking Compliance.** The following provisions apply to compliance with ~~Pay to Park~~ Parking Zone parking requirements:

a. ~~A person who fails to comply with a Port Parking Pay to Park Zone requirement may be issued a Parking Complaint and assessing a penalty for violation. The person issued a Parking Complaint and fails to pay a Pay to Park Zone parking charge when due shall be liable to the Port for the amount owed, and shall be liable for any late payment charge, tow fees, or vehicle immobilization penalties owed if the parking charge payment is not received when due.~~

b. ~~The Port is authorized to issue a written notice or a Parking Complaint to a person who has not complied with a Pay to Park Zone parking requirement and has an obligation to pay the Port as a result.~~

(1)

e. ~~The Port, or a Port designee on behalf of the Port, is authorized to issue a Courtesy Notice or a payment demand and to undertake collection activities to collect an unpaid Pay to Park Zone obligation.~~

~~(2)~~ If a person disputes a Port claim of non-compliance with a Parking Pay to Park Zone requirement, failure to pay a parking charge when due, or the contents of a Parking Complaint or payment demand, for any reason, the person may obtain a Port form to be used to state the reason(s) for their dispute at the Port Marina Building Administration Office or Port Website ("Dispute Form"). A completed Dispute Form may be filed with the Port in person at, or sent by mail to, the Port Marina Building Administration Office or be submitted to the Port at the Port Website. A properly completed and filed Dispute Form will be considered by the Executive Director or their designee if received within 30 days after the issuance of a Parking Complaint and if a Courtesy Notice is issued 30 days after issuance of the Courtesy Notice, or may be considered later in the Executive Director's discretion. The Executive Director or their designee may take any action they deem appropriate in response to the information in a Dispute Form filed with the Port, or received in some other manner, including obtaining more information, reducing or forgiving a parking charge, or undertaking or continuing collection activities.

~~— Failure to pay multiple Parking Complaints may result in the use of a vehicle immobilization device. To free the car from the immobilization device, the driver must pay all outstanding Parking Complaints. Removal of the immobilization device is only done during the Port's regular business hours of 8:00 am to 5:00 pm, Monday through Friday (excluding holidays).~~

~~— Failure to pay multiple Parking Complaints or vehicles parked in manner that is a hazard may result in towing of the vehicle. The vehicle shall be impounded and towed by a licensed towing company to the towing company's garage. The towing and storage of a vehicle pursuant to this Section shall create a lien against the vehicle and any property left within the vehicle in favor of the towing company as provided by ORS 87.152. The owner of the impounded vehicle, or the owner's authorized agent, may redeem such vehicle commencing the next business day following the impounding of the vehicle upon payment of the towing bill, vehicle storage fees in a per diem amount contractually established between the Port and the service provider. If redemption is not made within 30 days after the vehicle is impounded, then such vehicle may be disposed of by the towing company in accordance with the procedure provided for in the foreclosure of liens under ORS 87.152 et seq.~~

### **SECTION 35. Penalties and Payments.**

~~a.~~—A person who violates a provision of this ordinance shall commit an offense punishable by a fine as a Class A violation. Provided however, if an offense defined in this ordinance is also an offense governed by a provision of the Oregon Criminal Code or Oregon Motor Vehicle Code ("State Regulation") and the State Regulation offense category is lower than a Class A violation, the ordinance offense and fine payable shall be reduced to be the same as provided in the State Regulation.

(1)

~~b.~~—Each violation of a section or subsection of this ordinance shall constitute a separate offense.

(2)

~~e.~~—Each separate violation of this ordinance shall constitute a separate offense.

(3)

~~d.~~(4)— If a person fails to comply with any Pay to Parking Zone parking requirement established by the Port, the person shall owe the Port the amount established by the Board or Executive Director as a result of their failure to comply.

### **SECTION 36. Right of Removal to Exclude.**

~~No person shall remain on Port Property after being asked to leave~~The Port shall adopt, by resolution, a Board policy and procedure to exclude persons from Port Recreational Property and Parking Zones by a Peace Officer or by a Port employee who has reasonable grounds to believe the person has violated a provision of~~violate this ordinance or of~~Ordinance, the Oregon Criminal Code, or the person has threatened to do so.

No person shall cause or allow their personal property remain on Port Recreational Property after being directed to leave. Exclusion applies only to remain at a location on Port Recreational Property and Parking Zones after a Peace Officer or a Port employee has asked the person to remove or relocate the personal property as defined in Section 2.

**SECTION 37. Severability.** This ordinance shall be liberally constructed to effectuate the purposes of this ordinance. Each section, subsection or other portion of this ordinance shall be severable; the invalidity of any section, subsection, or other portion shall not invalidate the remainder.

**SECTION 38. Scrivener's Errors.** A scrivener's error in any portion of this ordinance may be corrected by order of the Port of Hood River Board of Commissioners.

**SECTION 3739. Ordinance Repealed.** Port Ordinance No. 24, An Ordinance Regulating Conduct on Port Property, dated ~~May 6, 2014~~ June 26, 2018, is hereby repealed and replaced by this ordinance.

First reading: \*, by the Port of Hood River Board of Commissioners.

Second reading and adoption: \*, by the Port of Hood River Board of Commissioners.

Effective Date: 30 days after date of adoption.

PORT OF HOOD RIVER  
1000 E. Port Marina Drive Hood River, OR 97031

---

Ben Sheppard, President





**ORDINANCE NO. 27**  
**AN ORDINANCE REGULATING CONDUCT ON PORT PROPERTY**

WHEREAS, the Port of Hood River desires to amend Ordinance Number 24 to update the Ordinance to allow persons designated by the Port of Hood River Board of Commissioners to exclude persons violating this Ordinance and/or criminal law from the Port's recreational properties;

WHEREAS, the Port of Hood River desires to amend Ordinance Number 24 to repeal the current parking regulations and to state that the Board will adopt a separate Board Policy and Procedure for Parking; AND NOW, THEREFORE, THE PORT OF HOOD RIVER ORDAINS AS FOLLOWS:

**SECTION 1. Scope of Ordinance.** This ordinance regulates conduct on Port Property, including at Port structures.

**SECTION 2. Definitions.** Unless the context requires otherwise, for purposes of this ordinance the following definitions and provisions stated in a definition apply:

**"Boat Launch"** means the concrete ramp on the east side of the Marina Boat Basin.

**"Camp"** means erecting a tent or shelter, arranging bedding or occupying a parked vehicle, trailer or camper for purposes of, or in such a way as will permit, sleeping or remaining Overnight.

**"Commercial Activity"** means any activity directed to the general public or between two or more persons or entities undertaken for profit or personal gain.

**"Courtesy Notice"** means a written notice delivered or sent to a person informing them that a Parking Complaint has been issued and about their payment obligation.

**"Event Site"** means Port Property which includes an improved vehicle parking area and beach access to the Columbia River, located north of Port way Avenue, west of the Nichols Basin inlet, south of the Columbia River, and east of the Jensen building.

**"Executive Director"** means the person the Board has appointed to act as the general manager of all Port operations.

**"Hook"** means Port Property which includes a peninsula located west of the western terminus of Portway Avenue, east of Wells Island, north of Interstate 84, and south of the Columbia River.

**"Interstate Bridge"** means the bridge owned by the Port which crosses the Columbia River from Hood River, Oregon to Washington.

**"Kiteboarding"** means pumping/drying kites, carrying inflated kites, rigging or attaching lines, launching and landing.

**"Marina Beach"** means Port Property located east of the Hood River and north of the Marina Park.

**"Marina Boat Basin"** means the river basin located north of the Marina Green and east of the Marina Park, used for launching and moorage of boats and pontoon airplanes, with access to the Columbia River.

**"Marina Boat Basin Area"** means Port Property located west of the Interstate Bridge approach road, south of the Marina Beach, east of the Hood River and north of Interstate 84.

**"Marina Green"** means Port Property which includes a grass recreation field located south of the Marina Boat Basin and north of Interstate 84.

**"Marina Park"** means the park setting and picnic shelter located east of the Hood River and west of the Marina Boat Basin.

**"Nichols Basin"** means the river basin north of Interstate 84, which runs south to north along the western boundary of the Spit, with access to the Columbia River.

**"Official Sign"** means all signs, signals, markings, devices and placards placed, erected or provided by the Port for the purpose of guiding, directing, warning or regulating vehicle or boat traffic or personal conduct. An Official Sign includes a Port message appearing on or from an electronic kiosk or other electronic device which provides information.

**"Overnight"** means between 11:00 p.m. and 6:00 a.m.

**"Parking Complaint"** means a written or electronic notice demanding payment issued by the Port placed on a vehicle or provided to a person who has violated a Parking Zone parking requirement.

**"Parking Pass"** means a Port-issued parking permit that authorizes a vehicle which displays the Parking Pass to be parked in a designated Port parking location at times specified and on terms required by the Port. The Board or Executive Director may establish Parking Pass parking locations or requirements.

**"Parking Zone"** means an area of Port Property designated as a parking zone described and/or depicted on a Port map or diagram, where the Port limits vehicle parking times and charges for vehicle parking at specified parking locations. These Port locations reserved for vehicle parking, which may be in a separate confined parking area or be shoulder spaces located adjacent to a curb along a Port access way, are not considered part of a public road or street subject to Oregon Motor Vehicle Code laws governing travel on a public road or street.

**"Pedestrian Bridge"** means the bridge owned by the Port of Hood River intended for pedestrian use which crosses the Hood River from the Marina Boat Basin Area leading to the southern terminus of the Spit access road.

**"Port Website"** means the official Port website, [portofhoodriver.com](http://portofhoodriver.com).

**"Port Property"** means real property in Hood River County, Oregon owned or controlled by the Port, and the Interstate Bridge.

**"Port Recreational Property"** means the following areas: Event Site; Hook; Marina Beach; Marina Boat Basin Area; Marina Green; Marina Park; Nichols Basin; and Spit.

**"Portway Avenue"** means a City of Hood River ("City") street running westerly from the intersection with North Second Street and easterly from the intersection with Eighth Street and includes connected Port roads extending in a straight line westerly from the west end of the City street and in a straight line easterly from the east end of the City street.

"**Spit**" means Port Property, which is a peninsula located north of Interstate 84, west of the Hood River, east of the Nichols Basin and south from the Columbia River including exposed land in the Columbia River which is occasionally submerged.

"**Transient Dock**" means Port Property located west of the Boat Launch and used for temporary tie-up and limited overnight moorage.

## **GENERALLY APPLICABLE REGULATIONS**

**SECTION 3. Commercial Activity.** No person shall engage in any Commercial Activity on Port Property without the prior approval of, and under the terms and conditions prescribed by the Port.

**SECTION 4. Littering.** No person shall litter on Port Property. For purposes of this section littering is defined as the dumping, throwing, placing, depositing or leaving, or causing to be dumped, thrown, deposited or left any refuse of any kind or any object or substance which tends to pollute, mar or deface.

**SECTION 5. Vegetation.** No person shall remove vegetation on Port Property without written permission from the Port.

**SECTION 6. Fireworks.** No person shall ignite fireworks or similar incendiary devices of any kind on Port Property, whether legally allowed in Oregon or not unless authorized by the Port in writing.

**SECTION 7. Animal Control.** No person shall bring an animal onto Port Property, or allow an animal to be on Port Property, except when the animal is leashed and under the control of an adult.

**SECTION 8. Animal Waste.** No person shall allow the feces of an animal in that person's care or control to remain anywhere on Port Property other than in a waste receptacle.

**SECTION 9. Launching Boats.** No person shall launch a motorized watercraft from Port Property except at the Marina Boat Basin.

**SECTION 10. Camping.** Except as permitted for Marina Boat Basin tenants in Section 24, no person shall camp Overnight on Port Property or Parking Zone.

**SECTION 11. Hunting.** No person shall discharge firearms, hunt, or attempt to trap or injure an animal on Port Property.

**SECTION 12. Fires.** No person shall build or attempt to build a fire on Port Property.

**SECTION 13. Drones, Remote-Controlled Aerial Devices.**

- (1) No person shall operate a remote-controlled flying or aerial device on or from Port property in a manner that violates FAA regulations governing such devices.
- (2) No person shall operate a remote-controlled flying or aerial device on or from Port Property after a Port employee requests the person not do so because the Port Employee has reasonable grounds to believe that activity may conflict with or impair other permitted uses on Port Property or may pose a hazard to others.

**SECTION 14. Kiteboarding.**

- (1) *Location Restrictions:* No person shall launch or operate a kite, kiteboard or training kite from Port Property other than where permitted by an Official Sign, or Marina Green and Marina Beach, except when prohibited by an Official Sign.
- (2) *Safety Restrictions:* No person shall launch or operate a kiteboard or training kite if the activity may conflict with or impair other permitted uses on Port Property or may pose a hazard to others.

**SECTION 15. Vehicle Parking.**

The Port shall adopt, by resolution, a Board policy and procedure for vehicle parking in the Port's Parking Zone. The Board policy and procedure shall establish the policy and procedure for the Port's establishment and enforcement of its Parking Zones.

**SECTION 16. Vehicle Speed.** No person shall operate a vehicle at a speed in excess of the posted speed.

**SECTION 17. Vehicles on a Path or Off a Road.**

- (1) No person shall operate a vehicle on any pedestrian path located on Port Property except a motorized wheelchair or device used to improve mobility for a disabled person, a Port maintenance vehicle and an emergency vehicle.
- (2) No person shall drive or park a vehicle on Port Property off a Port road or parking area without Port permission.

**SECTION 18. Official Signs.** No person shall engage in any conduct in violation of instructions or prohibitions appearing on an Official Sign on Port Property. No person shall place a sign on Port property without permission by the Port Executive Director or their designee. Contents of an Official Sign shall be approved by the Executive Director. If an Official Sign is placed by the Port on Port Property, the contents of the sign shall be deemed approved by the Executive Director.

**SECTION 19. Use Of Port Utilities.** No person shall connect an electrical device of any kind to a Port electrical power outlet or in any other manner use or interfere with electricity or water supplied to or by the Port on Port Property.

**SECTION 20. Fees.** No person shall refuse nor neglect to pay a fee or charge established by the Board or Executive Director for use of Port Property, Port facilities or Port services, when due.

**SECTION 21. Tobacco use.** No person shall use tobacco products of any kind, including cigars, cigarettes, e-cigarettes, vape pens, snuff or chewing tobacco while on Port Property or within Port buildings or facilities.

**SECTION 22. Port Permission.** No person may violate a provision of this ordinance unless the person is given express written permission to do so at a specific time or for a specific purpose by the Board or a Port employee, or an activity is allowed by an Official Sign. Such permission shall apply only to the expressly stated time, event, or activity.

## **SITE-SPECIFIC REGULATIONS**

**SECTION 23. Boat Launch and Transient Dock.**

- (1) No person shall park a vehicle in the Boat Launch parking lot Overnight.
- (2) No person shall dock a boat under 26 feet long to the Transient Dock for more than three consecutive nights.
- (3) No person shall dock a boat that is 26 feet in length or longer to the Transient Dock for more than ten consecutive nights in a 30-day period.

**SECTION 24. Marina Boat Basin.** All Marina Boat Basin tenants shall comply with the conditions of their moorage agreement and with moorage rules and regulations adopted by the Port. Unless otherwise allowed or prohibited by an Official Sign, the following activities are prohibited in the Marina Boat Basin or Marina Boat Basin Area:

- (1) No person shall jump or dive into, swim in, windsurf, or kiteboard in the Marina Boat Basin.
- (2) No person shall operate a boat, an airplane or any other type of watercraft in the Marina Boat Basin at a speed in a manner which causes a wake.
- (3) No person shall clean fish in the Marina Boat Basin or Marina Boat Basin Area.
- (4) No person shall stay on a boat or boathouse moored in the Marina Boat Basin for a period of time that violates a Port moorage rule or regulation.
- (5) No person shall park a vehicle at the Marina Boat Basin parking lot for more than three consecutive nights.
- (6) No parent, guardian, or person having custody or control of a child under the age of 16 years shall allow the child to be in a moored boat or boathouse in the Marina Boat Basin unaccompanied by an adult.

**SECTION 25. Marina Park.**

- (1) No person except a Marina moorage tenant or their guest shall operate or park a vehicle at the Marina Park between the posted hours.
- (2) No person shall park a vehicle on Marina Green grass.

**SECTION 26. Marina Beach.** No person shall recreate or otherwise use the Marina Beach in violation of an Official Sign or request of a Port employee.

**SECTION 27. Pedestrian Bridge.** The following activities are prohibited on the Pedestrian Bridge:

- (1) No person shall jump or dive from the Pedestrian Bridge.
- (2) No person shall drive a vehicle on the Pedestrian Bridge, with the exception of a motorized wheelchair or device used to improve mobility for a disabled person, and Port maintenance vehicles.
- (3) No person shall ride a bicycle, scooter or skateboard on the Pedestrian Bridge.

**SECTION 28. Spit.** No person shall drive or park a vehicle on the Spit north of the designated parking area.

**SECTION 29. Event Site.** No person shall engage in an activity related to kiteboarding, wing foiling or windsurfing at the Event Site except at times and in areas designated by an Official Sign.

**SECTION 30. Event Site & Nichols Basin Structures.** No person shall jump or dive from a wharf, pier, dock or pylon at or near the Event Site or the Nichols Basin. No person shall use a dock owned by the Port located at the Event Site or in the Nichols Basin without Port permission or unless allowed by an Official Sign.

**SECTION 31. Hook.** No person shall operate or park a vehicle at the Hook between the hours posted or when the Hook roadway entrance gate is closed.

**SECTION 32. Interstate Bridge.** The following activities are prohibited on the Interstate Bridge:

- (1) No person shall ride a bicycle on the Interstate Bridge.
- (2) No person shall operate an electronic bicycle, motorized scooter or skateboard on the Interstate Bridge.
- (3) No person shall walk onto or jump from the Interstate Bridge.
- (4) No person shall drive a vehicle in excess of the posted speed on the Interstate Bridge, unless a different speed is posted at an entrance to the Interstate Bridge, in which event the driver shall obey the posted speed. Emergency Vehicles are exempt from this requirement in cases of an emergency.
- (5) No person driving a vehicle shall pass another vehicle traveling in the same direction or pass a vehicle in the same lane of travel which is stopped on the Interstate Bridge.
- (6) No person shall stop, park, or leave a vehicle unattended on the Interstate Bridge.
- (7) No person shall drive a vehicle onto or across the Interstate Bridge without paying a bridge toll established by the Port.

## **ENFORCEMENT**

**SECTION 33. Enforcement of Ordinance.** The following persons have the authority to carry out the provisions of this Ordinance:

- (1) Port employees.

- (2) All peace officers as defined by ORS 133.005.
- (3) Licensed private security professionals as defined in ORS chapter 181 and appointed by the Board.
- (4) For Parking Zone violations, any person appointed by the Executive Director.

**SECTION 34. Parking Compliance.** The following provisions apply to compliance with Parking Zone parking requirements:

- (1) A person who fails to comply with a Port Parking Zone requirement may be issued a Parking Complaint and assessing a penalty for violation. The person issued a Parking Complaint shall be liable for any late payment charge, tow fees, or vehicle immobilization penalties owed if the parking charge payment is not received when due.
- (2) If a person disputes a Port claim of non-compliance with a Parking Zone requirement, failure to pay a parking charge when due, or the contents of a Parking Complaint or payment demand, for any reason, the person may obtain a Port form to be used to state the reason(s) for their dispute at the Administration Office or Port Website ("Dispute Form"). A completed Dispute Form may be filed with the Port in person at, or sent by mail to, the Administration Office or be submitted to the Port at the Port Website. A properly completed and filed Dispute Form will be considered by the Executive Director or their designee if received within 30 days after the issuance of a Parking Complaint and if a Courtesy Notice is issued 30 days after issuance of the Courtesy Notice or may be considered later in the Executive Director's discretion. The Executive Director or their designee may take any action they deem appropriate in response to the information in a Dispute Form filed with the Port, or received in some other manner, including obtaining more information, reducing or forgiving a parking charge, or undertaking or continuing collection activities.

**SECTION 35. Penalties and Payments.**

- (1) A person who violates a provision of this ordinance shall commit an offense punishable by a fine as a Class A violation. Provided however, if an offense defined in this ordinance is also an offense governed by a provision of the Oregon Criminal Code or Oregon Motor Vehicle Code ("State Regulation") and the State Regulation offense category is lower than a Class A violation, the ordinance offense and fine payable shall be reduced to be the same as provided in the State Regulation.
- (2) Each violation of a section or subsection of this ordinance shall constitute a separate offense.
- (3) Each separate violation of this ordinance shall constitute a separate offense.
- (4) If a person fails to comply with any Parking Zone parking requirement established by the Port, the person shall owe the Port the amount established by the Board or Executive Director as a result of their failure to comply.

**SECTION 36. Right to Exclude.**

The Port shall adopt, by resolution, a Board policy and procedure to exclude persons from Port Recreational Property and Parking Zones who violate this Ordinance, the Oregon Criminal Code, or the person has threatened to do so. No person shall remain on Port Recreational Property after

being directed to leave. Exclusion applies only to Port Recreational Property and Parking Zones as defined in Section 2.

**SECTION 37. Severability.** This ordinance shall be liberally constructed to effectuate the purposes of this ordinance. Each section, subsection or other portion of this ordinance shall be severable; the invalidity of any section, subsection, or other portion shall not invalidate the remainder.

**SECTION 38. Scrivener's Errors.** A scrivener's error in any portion of this ordinance may be corrected by order of the Port of Hood River Board of Commissioners.

**SECTION 39. Ordinance Repealed.** Port Ordinance No. 24, An Ordinance Regulating Conduct on Port Property, dated June 26, 2018, is hereby repealed and replaced by this ordinance.

First reading: \*, by the Port of Hood River Board of Commissioners.

Second reading and adoption: \*, by the Port of Hood River Board of Commissioners.

Effective Date: 30 days after date of adoption.

PORT OF HOOD RIVER  
1000 E. Port Marina Drive Hood River, OR 97031

---

Ben Sheppard, President



**PORT OF HOOD RIVER**  
**Resolution No. 2023-24-\_\_\_**

**A RESOLUTION CREATING AN EXCLUSION POLICY AND PROCEDURE FOR  
PORT PROPERTY**

**WHEREAS**, Port of Hood River Ordinance No. 27 regulating conduct on port property was adopted upon a second reading on May 2, 2023; AND

**WHEREAS**, Section 36 of Ordinance No. 27 states that the Port shall adopt, by resolution, a Board policy and procedure to exclude persons from Port property who violate Ord. No. 27; NOW THEREFORE

THE PORT OF HOOD RIVER BOARD OF COMMISSIONERS RESOLVES AS FOLLOWS:

**Section 1. Purpose.** The purpose of this policy is to maintain a safe environment for recreational activities on designated areas owned by the Port of Hood River, by excluding persons from Port Recreational Property or Parking Zones who violate Port ordinances or the Oregon Criminal Code.

**Section 2. Authority.** ORS 777.190; ORS 164.205; Port of Hood River Ordinance No. 27

**Section 3. General Policy.** It is the policy of the Port of Hood River to provide the public with access to certain facilities for recreational purposes. However, when persons engage in behavior that causes concern for the health, safety and welfare of Port employees and other users, those persons may be excluded from further access. The Port Board of Commissioners has delegated authority to certain persons in charge to exclude persons from Port Property to ensure a safe recreational environment.

**Section 4. Procedures for Exclusion.** The following are the procedures to exclude persons who engage in behavior in violation of Port ordinances or criminal law.

**A. Person In Charge:** The person in charge of Port-owned property and buildings and authorized to forbid persons is the Port Executive Director, Deputy Executive Director, and General Counsel. The Port Executive Director is authorized to further delegate authority to order the exclusion of persons from Port-owned recreational property or parking areas.

**B. Conduct:** A person is subject to immediate exclusion from Port Recreational Property or Parking Zones if that person is observed to be engaged in any of the following types of conduct:

- i. Conduct in violation of the Oregon Criminal Code
- ii. Conduct that violates Ordinance Number 27 Regulating Conduct on Port Property

**C. Exclusion Orders:** All exclusion orders must be in writing and must state the basis for the order and appeal information. The notice must be served personally or mailed to the person by certified mail if a mailing address is available. The Port Administration Office shall record and keep on file the exclusion notice during the term of exclusion. The exclusion remains in effect for the specified period unless it is modified or rescinded as a result of an appeal. If a person who receives

a notice of exclusion remains or returns to Port Recreational Property without giving proper notice as described in Section 4, that person may be subject to arrest on criminal trespass charges.

D. Exclusion Period: A person in violation may be excluded for a period of up to six (6) months. During the exclusion period, the person may enter the Port Administration Office, to conduct necessary official business during normal business hours.

E. Appeal

- i. An exclusion may be appealed by filing a notice of appeal within five days after being served with the notice of exclusion. If service is by mail, the date of service shall be three days after the mail is postmarked. The notice of appeal must be mailed to the Port Executive Director and will be considered timely only if postmarked or received within the five-day period.
- ii. The Port Executive Director will arrange for a hearing on the issue in front of an impartial hearings officer within five days of receiving the request. The hearings officer may be a Port employee so long as the employee has no personal involvement in the decision to exclude. The review shall be informal.
- iii. The hearings officer shall consider any evidence and argument that the hearings officer considers relevant to whether the exclusion or prohibition is consistent with this policy, or any applicable law. This may include affidavits or declarations from involved persons. The hearing officer shall issue the decision within 5 days of the hearing. The hearing decision is final.

**Section 5. Effective Date.** This resolution goes into effect concurrently with the effective date of Port of Hood River Ordinance No. 27.

Adopted by the Board of Commissioners of the Port of Hood River this 2nd day of May, 2023.

**SIGNED**

\_\_\_\_\_  
Ben Sheppard, President

**ATTEST**

\_\_\_\_\_  
Michael Fox, Secretary

# Commission Memo

Prepared by: Genevieve Scholl, Daryl Stafford  
Date: April 18, 2023  
Re: Resolution Approving Changes to  
Waterfront Parking System

---



The attached resolution is being recommended based upon the staff's approach to managing the waterfront. Amendments necessary based upon the earlier agenda discussion item may need to be incorporated into the recommended motion.

**RECOMMENDATION:** Approve Resolution No. 2022-23-12 setting waterfront parking rates, fees, zones and hours.

This page intentionally left blank.

**PORT OF HOOD RIVER**  
**Resolution No. 2022-23-12**

**A RESOLUTION SETTING WATERFRONT PARKING RATES, FEES, ZONES  
AND HOURS**

**WHEREAS**, the Port of Hood River Board of Commissioners regulates the use of Port Property through its Property Ordinance, last adopted via Ord. No. 26 (24-2018) on June 26, 2018;  
AND

**WHEREAS**, the Commission would like to create a policy for the management of the waterfront; NOW, THEREFORE

THE PORT OF HOOD RIVER BOARD OF COMMISSIONERS RESOLVES AS FOLLOWS:

**Section 1. Pay to Park Zones and Hours.**

- A.** Payment for parking will be required between the hours of 8:00 a.m. and 6:00 p.m. No parking is allowed on any Port-owned lots and streets between the hours of 11:00 p.m. and 6:00 a.m. There is no maximum stay limit for any designated parking space between the hours of 6:00 a.m. and 11:00 p.m.
- B. Zone 1:** Encompasses all Port-owned streets and parking lots west of Nichols Basin, except for the Event Site Parking Lot. (Nichols Basin parking lot, N. 1<sup>st</sup> Street, Lot 1, westernmost block of Portway Avenue, western half of the West Jensen Parking lot, easternmost block of Portway Avenue, and the Hook).
- C. Zone 2:** The Event Site Parking Lot (and Lot 1 overflow parking when full).
- D. Zone 3:** The Marina Boat Launch Parking Lot.

**Section 2. Free to Park Zones and Hours.** No payment is required for parking in the Spit Parking Lot, the Marina Beach Parking Lot, and the Marina Moorage Parking Lot. No parking is allowed on any Port-owned lots and streets between the hours of 11:00 p.m. and 6:00 a.m., and no parking is allowed in Free-to-Park lots after 9:00 p.m.

**Section 3. Parking Rates and Fees.**

Parking rates in all Zones will be \$2.50 per hour (per parking space occupied), up to \$15 per day for regular length vehicles, and \$25 per day for overlength vehicles parked at the Event Site.

Annual season passes valid for parking in the Event Site, Lot 1 overflow parking, and West Jensen (excluding overlength vehicles) will be \$200 for vehicles up to 20' and \$350 for vehicles over 20'. Passes are valid January 1 – December 31 for lot open hours only. Passes are not valid for on street parking.

#### **Section 4. Vehicle Types Allowed in Parking Lots.**

- A. Event Site Parking Lot:** Gates are open 7:00 a.m. to 9:00 p.m. Payment required between 8:00 a.m. and 6:00 p.m. Regular Length Vehicles (up to 20' in total length) and Overlength Vehicles (over 20' in total length) are allowed.
- B. West Jensen Parking Lot:** Open all hours. Payment required between 8:00 a.m. and 6:00 p.m. Overlength Vehicles (over 20' in total length) are NOT allowed.
- C. Nichols Basin Parking Lot:** Open all hours. Payment required between 8:00 a.m. and 6:00 p.m. Regular Length Vehicles (up to 20' in total length) and Overlength Vehicles (over 20' in total length) are allowed.
- D. Marina Boat Launch Parking Lot:** Open all hours. Payment required between 8:00 a.m. and 6:00 p.m. Regular Length Vehicles (up to 20' in total length) and Overlength Vehicles (over 20' in total length) are allowed.
- E. Spit, Marina Beach and Marina Moorage parking lots -** Regular Length Vehicles (up to 20' in total length) and Overlength Vehicles (over 20' in total length) are allowed. Commercial Trucks are not allowed. Commercial trucks are defined as a tractor or tractor trailer combination in excess of 10,000 gvw. No parking allowed in these lots after 9:00 p.m.

#### **Section 5. Vehicle Types Allowed on Streets and Roads.**

- A. The Hook:** Open all hours. Payment required between 8:00 a.m. and 6:00 p.m. Overlength Vehicles (over 20' in total length) are NOT allowed. Parking in designated spaces only. Vehicles parked in FIRE ZONES or in any way impeding access of emergency response vehicles will be towed at the owner's expense.
- B. West Portway Avenue:** Open all hours. Payment required between 8:00 a.m. and 6:00 p.m. Passenger vehicles allowed 7 days a week. Commercial trucks not allowed May 15 through October 15. Overnight parking for commercial trucks is only allowed October 16 – May 14. Commercial trucks are defined as a tractor or tractor trailer combination in excess of 10,000 gvw.
- C. North 1<sup>st</sup> Street and East Portway Avenue:** Open all hours. Payment required between 8:00 a.m. and 6:00 p.m. Passenger vehicles allowed 7 days a week. Commercial trucks not allowed May 15 through October 15. Commercial trucks are defined as a tractor or tractor trailer combination in excess of 10,000 gvw.

#### **Section 6. Violation Penalties**

- A. Non-payment (per parking space) - \$40
- B. Parking in Unauthorized Space - \$30
- C. After Hours Parking (anytime between 11:00 p.m. to 6:00 a.m. all Zones AND after 9:00 p.m. in the Event Site Parking Lot) - \$40
- D. Non-payment of violation penalty after 30 days of issuance - \$15
- E. Non-payment of violation penalty after 60 days of issuance - \$25
- F. Non-payment of violation penalty after 90 days of issuance – Send to collections, will include collections fees assessed by Duncan Solutions.

**Section 7. Payment Method**

- A. **All Zones: Pay-by-Text or Mobile App only.** (No cash payment. No payment kiosks. No Event Site Parking Booth.)
- B. **Event Site Parking Lot, Lot 1, and West Jensen Parking Lot: Annual season pass option** allowed in these lots. (No overlength passes/vehicles allowed in West Jensen lot).
- C. Parking violation payment accepted by cash, check, or credit card at the Port office during regular business hours or via U.S Mail.

**Section 8. Annual Review.** The Commission, through assistance by Port staff, shall annually review and adopt a new rate, fees and charges resolution prior to the subsequent budget’s adoption. Any fee adjustments to this policy may be done through an annual rate adjusting resolution.

**Section 9. Effective Date.** The effective date of this resolution is May 1, 2023.

**Section 10. Repealer.** All previous rates and/or policy resolution regarding waterfront parking are hereby repealed.

Adopted by the Board of Commissioners of the Port of Hood River this 18th day of April 2023.

**SIGNED**

\_\_\_\_\_  
Ben Sheppard, President

**ATTEST**

\_\_\_\_\_  
Michael Fox, Secretary

This page intentionally left blank.



# Commission Memo



Prepared by: John Mann, Ryan Klapprich

Date: March 18, 2023

Re: Authorize Bid Process for Miscellaneous Truss Repairs.

---

During the 2022 Fracture Critical inspection, it was determined some miscellaneous steel repairs need to be made in addition to some spot cleaning of the bridge structure. HDR Engineering has prepared bid documents to accomplish these maintenance repairs.

Engineers Estimate for this work is \$40,000.

**RECOMMENDATION:** Approve issuance of bid solicitation for Miscellaneous Truss Repairs.

This page intentionally left blank.

# Port of Hood River Miscellaneous Truss Repairs

Issued: April 20, 2023

## **PORT OF HOOD RIVER**

1000 E. PORT MARINA DRIVE  
Hood River, Oregon 97031  
John Mann  
FACILITIES DIRECTOR

**Consultant:** **HDR Engineering, Inc.**  
Mark Libby, PE  
1050 SW 6<sup>th</sup> Ave., Suite 1800  
Portland, OR 97204  
Telephone: 503-423-3757  
Email: mark.libby@hdrinc.com

**Owner:** **PORT OF HOOD RIVER**  
1000 E. Port Marina Drive  
Hood River, Oregon 97031  
Telephone: (541) 386-1645  
Fax: (541) 386-1395  
porthr@gorge.net  
www.portofhoodriver.com

# Miscellaneous Truss Repairs

## Bid Solicitation

### Table of Contents

PART 1	Schedule	Page 4
PART 2	Invitation to Bid	Page 6
PART 3	Instructions to Bid (ITB)	Page 8
PART 4	Bid Form Bid Sheet Contractor Registration Form First Tier Subcontractor Disclosure Form	Page 16
PART 5	Bid Bond Form	Page 23
PART 6	Performance and Payment Bond	Page 25
PART 7	Certificate of Insurance Form	Page 30
PART 8	General Conditions (A-L)	Page 32
PART 9	Technical Specifications	Page 62
PART 10	Construction Plans (Bound separately and incorporated by reference)	Page 81
PART 11	Port of Hood River Public Improvement Contract (sample)	Page 83

**PART 1**  
**SCHEDULE**

## SCHEDULE

<b>Invitation to Bid Advertised</b>	April 20, 2023
<b>Bids Due</b>	May 11, 2023, 2 P.M. PDT
<b>Bid Opening</b>	May 11, 2023, 2 P.M. PDT
<b>First-Tier Subcontractor Disclosure Form Due</b>	May 11, 2023, 4 P.M. PDT
<b>Contractor Experience Reference Projects</b>	May 11, 2023, 4 P.M. PDT
<b>Notice of Intent to Award Issued</b>	May 18, 2023
<b>Protest Deadline</b>	May 25, 2023
<b>Award of Contract</b>	June 1, 2023
<b>Required Documents Due from Awarded Contractor (Including bonding and insurance)</b>	June 1, 2023
<b>Substantial Completion</b>	August 25, 2023
<b>Final Completion</b>	September 15, 2023

**PART 2**  
**INVITATION TO BID**

## **Invitation to Bid Miscellaneous Truss Repairs**

The Port of Hood River is requesting bids for Miscellaneous Truss Repairs for the Hood River-White Salmon Interstate Bridge at Hood River, Oregon 97031. This work includes miscellaneous truss repairs consisting of: connection repairs, floorbeam knee brace repairs, rocker bearing modifications, debris removal, joint header repair, and sealing concrete cracks. This is a Prevailing Wage project subject to ORS 279C.800 to 279C.870.

Beginning Thursday, April 20, 2023 at 2:00 P.M. PDT a complete solicitation document, including scope of work, sample contract, and design specifications, will be posted to the Port of Hood River's projects on the Oregon Buys website at: <https://oregonbuys.gov/bsol/>. Hard copies may be examined or purchased during normal business hours at:

Port of Hood River  
1000 E. Port Marina Drive  
Hood River, Oregon 97031

There will be a \$35 nonrefundable charge for each printed copy of the solicitation document. The document can also be viewed or printed online at <https://oregonbuys.gov/bsol/>. Any subsequent addenda, clarifications, or project documents will be posted to the Oregon Buys website.

There is no mandatory pre-bid meeting for this project.

Bidders are not required to be pre-qualified under ORS 279C.430.

Bids must be submitted in hard copy only and must be addressed to John Mann, Facilities Director, Port of Hood River. Bids must be received at the Port office located at 1000 E. Port Marina Drive, Hood River OR 97031 by **2:00 P.M. PDT on Thursday, April 20, 2023**. Bids will not be accepted after 2:00 P.M. PDT on Thursday, April 20, 2023. Bids will be publicly opened in the Port office immediately following the bid deadline.



**PART 3**  
**INSTRUCTIONS TO BID**

## **INSTRUCTIONS TO BID**

**OWNER:** Port of Hood River, 1000 E. Port Marina Drive, Hood River, OR 97031, Telephone (541) 386-1645, Fax (541) 386-1395, Email porthr@gorge.net, Website [www.portofhoodriver.com](http://www.portofhoodriver.com).

This Invitation to Bid and the resulting Contract are governed by Oregon Law. Specific laws and rules that govern the solicitation process are found in Chapters 279A and 279C of the Oregon Revised Statutes (ORS), and Chapter 137, Divisions 046 and 049 of the Administrative Rules of the Oregon Department of Justice (OAR). Bidders should obtain and become acquainted with the applicable provisions of the above laws and rules.

### **DESCRIPTION**

Bids are requested to perform miscellaneous truss repairs of the Hood River-White Salmon Interstate Bridge. This is a Prevailing Wage Project subject to ORS 279C.800 to 279C.870. Project scope of work, plans and specifications are included in this Contract Solicitation document or attached by reference.

The work contemplated under this Contract includes all labor, tools, machinery, materials, transportation, equipment and services necessary for, and reasonably incidental to, the completion of all work in connection with the project described in the Contract, the General Conditions, all applicable special conditions, plans, specifications, and addenda.

All questions regarding the project should be directed via email (not phone) to **John Mann at [jmann@portofhoodriver.com](mailto:jmann@portofhoodriver.com)**. Questions and answers will be posted on the project page on the Oregon Buys website. Contractor names will not be included.

### **INVITATION TO BID DOCUMENT AVAILABILITY**

A complete solicitation document may be examined or obtained (\$35.00) during normal working hours at the Port office, 1000 E. Port Marina Drive, Hood River, Oregon after 2:00 P.M. PDT on Thursday, April 20, 2023 or by calling the Port Office (541)386-1645. Plans will be available to download at the Port of Hood River project page on the Oregon Buys website at <https://oregonbuys.gov/bsol/>.

### **SOLICITATION LAW AND RULES**

This ITB and resulting Contract are governed by Oregon Law. Specific laws and rules that govern the solicitation process are found in Chapters 279A and 279C of the Oregon Revised Statutes, and Chapter 137, Divisions 046 and 049 of the Administrative Rules of the Oregon Department of Justice (Model Public Contracting Rules). The ITB and resulting Contract may be subject to other laws and rules. Offerors should obtain and become acquainted with the applicable provisions of the above laws and rules.

### **BRAND NAME USAGE:**

Any brand name listed in the specifications without an "or approved equal" shall establish the minimum requirements for quality, utility, durability, function and purpose. Other brand names may be used in the construction of the product as long as they are equal to or better than the product brand named, and the brand name listed is not mandated pursuant to a brand name exemption.

Any brand name listed in the specifications with an "or approved equal" shall establish the minimum requirements for quality, utility, durability, function and purpose. Other brand names may be used in the construction of the project as long as they are equal to or better than the product brand named, and the proposed product has been approved in writing by the Owner's Authorized Representative prior to installation, and the brand named is not mandated pursuant to a brand name exemption.

The Owner's Representative shall determine, in its sole discretion, whether a product is "or approved equal."

Any brand name listed in the specifications with an "or approved equal" or an "or approved equivalent" shall establish the minimum requirements for quality, utility, durability, function and purpose. Other brand names may be used in the construction of the project as long as they are equal to or better than the product brand named, and the proposed product has been approved in writing during the bidding process detailed in the following section and the brand named is not mandated pursuant to a brand name exemption.

**SOLICITATION PROTEST; REQUEST FOR CHANGE; REQUEST FOR CLARIFICATION; REQUEST FOR BRAND NAME/PRODUCT SUBSTITUTION**

If a Bidder finds discrepancies in, or omissions from the plans, specifications or Contract documents, or has doubt as to their meaning, the Bidder shall at once notify the Owner. The Owner will then investigate and determine if an Addendum will be issued.

Bidders may, in writing, request brand approval, requests for substitutions, requests for clarifications, requests for change, Bid protest. The Owner must receive this written protest or request no later than five (5) calendar days prior to the Bid Closing date. The written protest or request shall include the reasons for the protest or request, and any proposed changes to the Bid specifications or contract terms. Envelopes containing Bid protests shall be marked as follows: "Contract Provision Request for Change" or "Contract Provision Protest", and Solicitation Document Identification Project Title.

Clarifications, whether verbal, in writing, or included in an Addendum or Addenda as a "clarification," do not change Plans, Specifications, contractual terms, or procurement requirements of an ITB. If a request for clarification raises an issue that the Owner determines should be handled by formally amending the ITB, the Owner will do so only by announcing such a change in an Addendum or Addenda, not through information identified as a "clarification."

The Owner will promptly respond to each properly submitted written request for brand approval, request for substitution, request for change, and protest. Where appropriate, the Owner will issue ITB revisions via Addenda made by fax or email and will posted on the Owner's website. A Bidder shall provide written acknowledgement of receipt of all issued Addenda with its Bid.

INFORMAL RESPONSES DO NOT AFFECT THE PROVISIONS OF THE ITB. PROVISIONS OF THE ITB CAN ONLY BE CHANGED VIA ADDENDA ISSUED BY THE OWNER.

Pursuant to OAR 137-049-0250, no protest against award because of the content of bid specifications or contract terms shall be considered after the deadline established above for submitting protests of bid specifications or contract terms.

**EXAMINATION OF THE CONTRACT DOCUMENTS AND WORK SITE**

Bidders should carefully examine the bid and contract documents and familiarize themselves with the work site to fully acquaint themselves with all the conditions and matters which can in any way affect the work or the cost thereof.

Each bidder shall thoroughly examine and be familiar with legal and procedural documents, general conditions, specifications, drawings, plans, addenda (if any), and all other Contract Documents. The submission of a bid shall constitute an acknowledgment upon which the Port may rely, that the bidder is experienced in the uses and interpretation of plans and specifications such as those included in the Contract Documents and has thoroughly examined and is familiar with the Contract Documents.

The failure or neglect of a bidder to receive or examine any of the Contract Documents, perform site investigations and/or other investigations or examinations shall in no way relieve the bidder from any obligations with respect to the bid or the contract. No claim for additional compensation will be allowed which is based upon a lack of knowledge of any Contract Documents or existing site conditions.

**BID FORMAT**

**Sealed Bids** must be received in the Port office, 1000 E. Port Marina Drive, or by mail to 1000 E. Port Marina Drive, Hood River, OR 97031 on or before 2 P.M. PDT on Thursday, April 20, 2023.

All Bids must be sealed and received prior to the bid closing time and date. All Bids shall be prepared on hard copy, but must be signed in ink by an authorized representative of the Bidder. Email or facsimile Bids will not be accepted.

Required Information shall be submitted on the forms specific in the ITB.

The following forms and schedules shall be completed, signed and included in the bidder package and shall be submitted prior to the Bid Deadline:

- Bid Form
- Bid Sheet
- Contractor Registration Form
- Bid Bond Form

The following shall be submitted within two (2) working hours after Closing.

- First Tier Subcontractor Disclosure Form

Alteration and erasures made before Bid submission must EACH be INDIVIDUALLY initialed in ink by the person signing the Bid. Bids, once submitted, may be modified in writing before closing. Modifications made after Offer submissions shall be prepared on Bidder's letterhead, be signed by an authorized representative, and state that the modifications amend and supersede the prior bid. Failure to comply with the provisions of this paragraph shall result in Bid rejection. Nothing in this paragraph shall be construed as allowing the Bidder to alter or otherwise change the form of the proposal, the form of the Contract, the conditions of the Bid, the specifications, and/or plans attached to the Bid documents.

Modifications must be submitted in a sealed envelope marked as follows:

Miscellaneous Truss Repairs Bid  
 Closing Date  
 Bidder Legal Name  
 Oregon CCB #

Bidders may not modify bid after closing.

**BID SUBMISSION**

All Bid documents requiring signature must be signed in ink by an authorized representative.

Bids must be submitted in a sealed package or envelope. To ensure proper identification and handling, all packages and envelopes shall be clearly marked as follows:

Miscellaneous Truss Repairs Bid  
 Closing Date & Time  
 Bidder Legal Name  
 Oregon CCB #

Port of Hood River  
 Attn: John Mann  
 1000 E. Port Marina Drive  
 Hood River OR 97031

**BID WITHDRAWAL**

Bids may be withdrawn in writing submitted on the Bidder's letterhead, signed by an authorized representative, and received by the Owner prior to closing. Offer withdrawals submitted in writing must be labeled as such and contain the Project Name.

Bids may be withdrawn in person before Closing upon presentation of appropriate identification and evidence of authorization to act for Bidder. Signature confirmation of withdrawal may also be required.

**CLOSING & OPENING/FIRST TIER SUBMITTAL**

Bids will be received until 2:00 PM PDT on Thursday, April 20, 2023 where they will be immediately opened publicly and read aloud. Award decisions will not be made at Bid opening.

Bids received after 2:00 PM PDT on Thursday, April 20, 2023 will be non-responsive and not be opened.

First Tier subcontractors disclosure forms must be returned within two (2) working hours after closing, at the Port of Hood River office, 1000 E. Port Marina Drive, Hood River, Oregon. Failure to comply with this requirement shall result in rejection of the Bid as non-responsive.

Prior to the Intent to Award Announcement, the Port of Hood River may post preliminary bid results on the project page on the Oregon Buys website at <https://oregonbuys.gov/bs/>. Such postings are preliminary and are not final until all submission materials are validated.

**BID ACCEPTANCE**

A Bid is a firm offer, irrevocable, valid and binding on the Bidder for not less than thirty (30) calendar days from the closing date.

The Port of Hood River may request, orally or in writing, that Bidders extend, in writing, the time during which the Port of Hood River may consider their Bid. If a bidder agrees to such extension, the Bid shall continue as a firm Bid, irrevocable, valid and binding on the Bidder for the agreed-upon extension period.

**METHOD OF AWARD**

The responsiveness and responsibility of Bidders and their proposed Subcontractors will be considered in making the award.

Base Bid, and alternates (if applicable), unless modified by addendum. The Port reserves the right to arrange the bid forms with alternates and additives, if such be to the advantage of the Port. The bidder shall bid on all alternates and additives set forth in the bid forms unless otherwise specified.

Award will be made to the lowest responsive and responsible bidder.

**BID EVALUATION CRITERIA**

Bids will be evaluated to identify the lowest responsive Bid submitted by a responsible Bidder and not otherwise disqualified. (Refer to OAR 137-049-0390). Adjustments made to account for reciprocal preferences will be for Offer evaluation purposes only. No such adjustments shall operate to amend Bidder's Bid or any Contract awarded pursuant thereto.

To be considered responsive, the Bidder must substantially comply in all material respects with applicable solicitation procedures and requirements and the solicitation documents. In making such evaluation, the Port of Hood River may waive minor informalities and irregularities.

Prior to award of a contract, the Port of Hood River will evaluate whether the apparent successful Bidder meets the applicable standards of responsibility identified in ORS 279C.375(2)(b) and OAR 137-049-0390. In doing so, the Port of Hood River may investigate the Bidder and request information in addition to that already required in the ITB, when the Port of Hood River, in its sole discretion, considers it necessary or advisable.

**BID SECURITY REQUIREMENTS**

A surety bond, irrevocable letter of credit issued by an insured institution as defined in ORS 706.008, cashier's or certified check, executed in favor of the Port of Hood River in the amount equal to ten percent (10%) of the total amount of the Bid, shall be submitted with or posted for

all Bids as bid security unless the Contract has been exempted from this requirement under ORS 279C.390.

If the undersigned fails to (1) execute the contract, (2) furnish a Performance and Payment Bond, or (3) furnish the certificates of insurance within ten (10) calendar days of the written Notice of Intent-to-Award a Contract, then the Port of Hood River may cash the check, draw under the letter of credit or otherwise collect under the Bid Security.

#### **PROCESSING OF BIDS**

Neither the release of Bid Security, nor acknowledgement that the selection process is complete (whether by posting of a bid tabulation sheet, issuance of Notice of Intent to Award, or otherwise), shall operate as a representation by the Port of Hood River that any Bid submitted was complete, sufficient, lawful in any respect, or otherwise in substantial compliance with the ITB requirements.

#### **WITHDRAWAL OF BID ITEMS**

The Port of Hood River reserves the right to withdraw Bid items. The deletion of one or more bid items will not affect the method of award.

#### **REJECTION OF BIDS**

The Port of Hood River may reject all Bids for good cause upon finding that it is in the public interest to do so.

The Port of Hood River may reject a particular Bid for any reason listed under OAR 137-049-0440.

#### **INTENT-TO-AWARD ANNOUNCEMENT**

The Port of Hood River reserves the right to announce its Intent-to-Award prior to formal Contract award by posting the tabulation sheet of Bid results on the project page on the Oregon Buys website, <https://oregonbuys.gov/bs/>, or by letter or fax. The Intent-to-Award Announcement shall serve as notice to all Bidders the Port of Hood River intends to make an award.

#### **PROTEST OF INTENT-TO-AWARD**

Adversely affected or aggrieved Bidders shall have seven (7) calendar days from the date of the Intent-to-Award Announcement within which to file a written protest. Protests submitted after that date will not be considered. Protests must specify the grounds upon which the protest is based.

In order to be an adversely affected or aggrieved Bidder, the Bidder must claim to be eligible for award of the contract as the lowest responsible and responsive Bidder and that any and all lower Bidders are ineligible to receive Contract award.

An Actual Bidder who is adversely affected or aggrieved by the award of the Contract to another Bidder may protest award, in writing, within the timeline established. The written protest shall state the grounds upon which the protest is based. No protest of award shall be considered after the deadline.

#### **RESPONSE TO INTENT-TO-AWARD PROTESTS**

The Port of Hood River will respond in writing to Intent-to-Award protests submitted by adversely affected or aggrieved Bidders. The Port of Hood River may also respond to Intent-to-Award protests submitted by other Bidders for the purpose of clarification. However, any response made by the Port of Hood River is not intended to, and shall not in and of itself constitute, confirmation that the Bidder is, in fact, adversely affected or aggrieved, and therefore entitled to protest an Intent-to-Award, or that the protest was timely filed.

#### **AWARD**

After expiration of the seven (7) calendar day Intent-to-Award protest period, and resolution of all protests, the Port of Hood River may proceed with final award. If the Port of Hood River

receives only one Bid, the Port of Hood River may dispense with the Intent-to-Award protest period and proceed with award of a Contract.

**COMMENCEMENT OF WORK**

Contractor shall not commence Work under this Contract until the Notice to Proceed has been issued.

**REVIEW OF AWARDED BID FILES**

Awarded Bid files are public records and available for review at the Port of Hood River office by appointment during regular business hours (Monday through Friday, 8am until 5pm).

**INFORMATION TO BE SUBMITTED BY APPARENT SUCCESSFUL BIDDER**

The apparent successful Bidder shall provide all required proof of insurance to the Port of Hood River within ten (10) calendar days of notification of the Intent-to-Award. Failure to present the required documents within ten (10) calendar days may result in Bid rejection. Bidders are encouraged to consult their insurance agent about the insurance requirements as identified in Section G of the General Contract Conditions prior to Bid submission.

Bidders must satisfy these insurance requirements by obtaining insurance coverage from insurance companies or entities acceptable to the Port of Hood River that are allowed to provide such insurance under Oregon law.

The successful Bidder shall be required to furnish a Performance and Payment Bond each in the total amount of one hundred percent (100%) of the awarded contract, executed in favor of the Port of Hood River, to ensure faithful performance of the Contract and payment for services and goods.

The apparent low bidder shall provide all required bonding to the Port of Hood River within ten (10) calendar days of notification of Intent-to-Award. Failure to present the required documents within ten (10) calendar days may be grounds for award disqualification.

The apparent successful Bidder, if a Joint Venture/Partnership, shall provide a copy of the Joint Venture Agreement or Partnership Agreement evidencing authority to Offer and to enter into the resulting Contract that may be awarded, together with corporate resolutions (if applicable) evidencing corporate authority to participate as a Joint Venture or Partner. A contact person must also be designated for purposes of receiving all notices and communications under the Contract. All Partners and Joint Venturers will be required to sign the Contract awarded.

**OREGON PREVAILING WAGES RATES (BOLI REQUIREMENTS)**

The Contractor and subcontractors shall comply with all the provisions of 279C.800 through 279C.870, relative to Prevailing Wage Rates. The current Prevailing Wage Rates for Public Works Contract in Oregon subject to the State PWR will apply to this project and can be found at:

<https://www.oregon.gov/boli/employers/pages/prevailing-wage.aspx>

The work takes place in Hood River County.

**FIRST-TIER SUBCONTRACTOR DISCLOSURE INSTRUCTIONS AND FORM**

Pursuant to ORS 279C.370, Bidders are required to disclose information about certain First-Tier Subcontractors when the Owner estimates the contract value for a Public Improvement to be greater than \$100,000. Specifically, when the Contract amount of a First-Tier Subcontractor furnishing labor, or labor and materials, has a Contract value that is equal to or greater than five percent (5%) of the total project bid or \$15,000, whichever is greater, or \$350,000 regardless of the percentage of the total project bid, the Bidder must disclose the following

information about that Subcontract in its Bid submission or within two (2) working hours after Bid Closing:

- a) Subcontractor's name;
- b) Category of work that Subcontractor would be performing;
- c) Dollar value of each Subcontract.

If the Bidder will not be using any subcontractors that are subject to the above disclosure requirements, the Bidder is required to write "NONE" on the Disclosure Form.

The Port of Hood River must reject a Bid if the Bidder fails to submit the disclosure form with this information by the stated deadline.

The Bidder must submit the Disclosure Form required by OAR 137-049-0360 either in its Bid submission or within two (2) working hours after closing.

The Port of Hood River shall obtain, and make available for public inspection, the Disclosure Forms required by OAR 137-049-0360. The Port of Hood River shall also provide copies of the Disclosure Forms to the Bureau of Labor and Industries as required by ORS 279C.835. The Port of Hood River is not required to determine the accuracy or completeness of the information submitted. Substitution of affected first-tier subcontractors shall be made only in accordance with ORS 279C.585.



**PART 4**

**BID FORM, BID SHEET, CONTRACTOR REGISTRATION FORM, AND  
FIRST TIER SUBCONTRACTOR DISCLOSURE FORM**

**BID FORM**

**DATE:** \_\_\_\_\_

**PORT OF HOOD RIVER  
1000 E. PORT MARINA DRIVE  
HOOD RIVER, OREGON 97031**

**PRICE SUBMITTAL:**

The Undersigned proposes and agrees, if this Bid is accepted, to enter into an agreement with the Port of Hood River to furnish all Work as specified or indicated herein for the ITB indicated and within the schedule indicated in the Invitation to Bid. Bidder has familiarized itself with the Work and has visited and inspected the site and is familiar with all the field conditions, legal requirements (federal, state, and local laws, ordinances, rules and regulations), and conditions affecting cost, progress and performance of work, and has made such independent investigations as Bidder deems necessary. Bidder has given the Port written notice of all conflicts, errors, and/or discrepancies that it has discovered in the Contract Documents and the written resolution thereof by the Port is acceptable to Bidder.

**BASE BID: Miscellaneous Truss Repairs**

FOR THE LUMP SUM OF: \$ \_\_\_\_\_ . (\$ \_\_\_\_\_ )

**CHANGES TO THE WORK**

- A. If adjustments to the work occur, the Bid Sheet will be used for basis of cost adjustment. If quantities are adjusted by more than 25% equitable overhead factor may be applied.

The Undersigned agrees, if awarded the Contract, to complete this work not later than:

\_\_\_\_\_, 20\_\_.

Company: \_\_\_\_\_ Telephone: \_\_\_\_\_

Company Address: \_\_\_\_\_

Email: \_\_\_\_\_ Fax: \_\_\_\_\_

Construction Contractors Board Number \_\_\_\_\_ Expiration Date \_\_\_\_\_

I attest that I have the authority to commit the firm named above to this Bid amount and acknowledge that the firm meets the qualifications necessary to perform this work as outlined in the Invitation to Bid. I understand that I will be required to provide necessary information to verify that the firm meets these qualifications if selected for the Contract.

By: \_\_\_\_\_

---

Signature / Name & Title / Date

## BID SHEET

Spec Item	Description	Qty	Unit	Unit Cost	Total
00210	Mobilization	1	LS		
00221	Temporary Work Zone Traffic Control, Complete	1	LS		
00253	Temporary Work Access and Containment	1	LS		
00542	Joint Header Repair	1	EA		
00542	Pier Crack Sealing	14	EA		
00560	Stringer Connection Repair	19	EA		
00560	Floorbeam Knee Brace Repair	2	EA		
00560	Light Pole Connection Repair	1	EA		
00560	Debris Removal	1	LS		
00560	Rocker Bearing Modification	5	EA		
00560	Truss Chord Repair	1	EA		
		<b>Total Bid</b>			
<b>Written Bid Total:</b>					

<b>Contractor Name</b>	
<b>Address</b>	
<b>Address</b>	
<b>City, State, Zip</b>	
<b>Phone</b>	
<b>Fax</b>	
<b>Email</b>	
<b>Registration Number</b>	
<b>Contact</b>	
<b>Phone</b>	

**CONTRACTOR REGISTRATION FORM**

This Bid must be signed in ink by an authorized representative of the Bidder; any alterations or erasures to the Bid must be initialed in ink by the undersigned authorized representative.

**1. CCB Requirements**

All Bidders shall be licensed with the State of Oregon Contractors Board (CCB) prior to bidding on Public Improvement Contracts. Failure to comply with this requirement shall result in Bid Rejection.

All subcontractors participating in the project shall be similarly registered with the State of Oregon Contractors Board at the time they propose to engage in subcontract work. The CCB registration requirements apply to all public works contracts unless superseded by federal law.

**Construction Contractors Board Number:** \_\_\_\_\_  
**Expiration Date:** \_\_\_\_\_

**2. Asbestos Abatement Licensing Requirements**

An asbestos abatement license under ORS 468A.720 will not be required of the Contractor or its subcontractors.

**3. Joint Venture/Partnership Disclosure**

The Undersigned has authority on behalf of the following entity and is (check one of the following and insert information requested):

- \_\_\_ a. A corporation organized and existing under the laws of the State of \_\_\_\_\_; or
- \_\_\_ b. A partnership/joint venture registered under the laws of the State of \_\_\_\_\_;  
If yes, name of the contact person for the partnership/joint venture \_\_\_\_\_; or
- \_\_\_ c. A limited liability corporation (LLC) or limited liability partnership (LLP) under the laws of the State of \_\_\_\_\_; or
- \_\_\_ d. An individual doing business under an assumed name registered under the laws of the State of \_\_\_\_\_.

**4. Addendum or Addenda Acknowledgement**

ADDENDA: The Undersigned hereby acknowledges receipt of the following Addenda:

<b>ADDENDUM NO.</b>	<b>DATED</b>	<b>ADDENDUM NO.</b>	<b>DATED</b>
_____	_____	_____	_____
_____	_____	_____	_____
_____	_____	_____	_____
_____	_____	_____	_____

**5. Responsibility Inquiry/ Contractor References**

(Provide (5) related project references and contact information)

**6. Recycled Products**

Bidder will comply with the recycled products provision in the Invitation to Bid in accordance with ORS 279A.125. Contractors shall use recyclable products to the maximum extent economically feasible in the performance of the contract work as set forth in this document.

**7. Residency Information**

Bidder is a ( ) Resident Bidder ( ) Non-resident Bidder

If a Resident Bidder, enter your Oregon business address:

\_\_\_\_\_  
\_\_\_\_\_

If a Non-resident Bidder, enter State of residency: \_\_\_\_\_

**8. Compliance with Tax Laws**

By my signature, I hereby attest or affirm under penalty of perjury: that I am authorized to act on behalf of the Contractor in this matter, that I have authority and knowledge regarding the payment of taxes, and that Contractor is, to the best of my knowledge, not in violation of any Oregon Tax Laws and any local tax laws administered by the Oregon Department of Revenue under ORS 305.620.

**9. Certification of Drug-Testing Law Requirements**

By my signature, I certify that Contractor shall demonstrate that an employee drug testing program is in place.

**10. Certification of Compliance with Non-Discrimination Laws**

By my signature, I hereby attest or affirm under penalty of perjury: that I am authorized to act on behalf of Contractor in this matter, and to the best of my knowledge, the Contractor has not discriminated against minority, women or emerging small business enterprises in obtaining any required subcontracts, and that the Contractor is not in violation of any Discrimination Laws.

**11. Signature of Bidder’s Duly Authorized Representative**

The Bid must be signed in ink by an authorized Representative of the Bidder. Any alterations or erasures to the bid must be initialed in ink by the undersigned authorized representative.

The undersigned acknowledges, attests and certifies individually and on behalf of the Bidder that:

1. He/She is a duly authorized representative of the Bidder, has been authorized by Bidder to make all representations, attestations, and certifications contained in this Bid and all Addendum or Addenda, if any, issued.
2. Bidder, acting through its authorized representatives, has read and understands all Bid instructions, specifications, plans, terms and conditions contained in this Bid document, including all attachments, exhibits, and Addenda, if any, issued.
3. The Bid submitted is in response to the specific language contained in the Invitation to Bid, and Bidder has made no assumptions based upon either (a) verbal or written statements not contained in the Invitation to Bid, or (b) any previously issued Invitation to Bid, if any.
4. The Owner shall not be liable for any claims or be subject to any defenses asserted by Bidder based upon, resulting from, or related to, Bidder’s failure to comprehend all the requirements of the Invitation to Bid.
5. The Owner shall not be liable for any expenses incurred by Bidder in preparing and submitting its Bid or in participating in the Bid evaluation/selection process.
6. The Bidder agrees to be bound by and comply with all applicable requirements of ORS 279C.800 through ORS 279C.870 and the administrative rules of the Bureau of

Labor and Industries (BOLI) regarding prevailing wage rates and payment of a fee to BOLI.

7. The Bid was (1) prepared independently from all other Bidders, and without collusion, fraud, or other dishonesty and without any agreement, understanding, or planned common course of action with, any other vendor of materials, supplies, equipment, or services described in the Invitation to Bid designed to limit independent bidding or competition; and (2) the contents of this Bid have not been communicated by the Undersigned or its employees or agents to any person not an employee or agent of the Undersigned or its surety on any bond furnished with the Bid and will not be communicated to such person prior to the official opening of the Bids.
8. Bidder is bound by and will comply with all requirements, specifications, plans, terms and conditions contained this Bid, including all attachments, exhibits and Addendum or Addenda, if any, issued.
9. Bidder will furnish the designated items and/or services in accordance with the Bid specifications, plans, and requirements, and will comply in all respects with the terms of the resulting Contract upon award.  
Bidder represents and warrants that Bidder has the power and authority to enter into and perform the Contract and that the Contract, when executed and delivered, shall be a valid and binding obligation of Contractor enforceable in accordance with its terms.
10. All affirmations and certifications contained in sections 6,7,8,9 and 10 are true and correct.

Authorized Signature \_\_\_\_\_

Title \_\_\_\_\_

FEIN ID # or SSN # \_\_\_\_\_

Contact Person: \_\_\_\_\_

Telephone Number ( ) \_\_\_\_\_ Fax ( ) \_\_\_\_\_

**FIRST-TIER SUBCONTRACTOR DISCLOSURE FORM**

**Project Name** \_\_\_\_\_

**Bid Opening Date** \_\_\_\_\_

**Name of Bidding Contractor** \_\_\_\_\_

**Email Address** \_\_\_\_\_

*CHECK THIS BOX IF YOU WILL NOT BE USING ANY FIRST-TIER SUBCONTRACTORS OR IF YOU ARE NOT SUBJECT TO THE DISCLOSURE REQUIREMENTS (SEE INSTRUCTIONS).*

**FIRST-TIER SUBCONTRACTORS**

<b>Firm Name</b>	<b>Dollar Amount</b>
<b>Category of Work</b>	

<b>Firm Name</b>	<b>Dollar Amount</b>
<b>Category of Work</b>	

<b>Firm Name</b>	<b>Dollar Amount</b>
<b>Category of Work</b>	

<b>Firm Name</b>	<b>Dollar Amount</b>
<b>Category of Work</b>	

<b>Firm Name</b>	<b>Dollar Amount</b>
<b>Category of Work</b>	

**PART 5**  
**BID BOND FORM**



**BID BOND FORM**

**Project Name: Miscellaneous Truss Repairs**

We, \_\_\_\_\_, as "Principal,"  
(Name of Principal)

And \_\_\_\_\_, an \_\_\_\_\_ Corporation,  
(Name of Surety)

authorized to transact Surety business in Oregon, as "Surety," hereby jointly and severally bind ourselves, our respective heirs, executors, administrators, successors and assigns to pay unto the Port of Hood River ("Obligee") the sum of (\$ \_\_\_\_\_) \_\_\_\_\_ dollars.

NOW, THEREFORE, if the bid submitted by Principal is accepted, and if a contract pursuant to the bid is awarded to Principal, and if Principal enters into and executes such contract within the time specified in the procurement document and executes and delivers to Obligee its good and sufficient performance and payment bonds required by Obligee, as well as any required proof of insurance, within the time fixed by Obligee, then this obligation shall be void; otherwise, it shall remain in full force and effect.

IN WITNESS WHEREOF, we have caused this instrument to be executed and sealed by our duly authorized legal representatives this \_\_\_\_\_ day of \_\_\_\_\_, 20\_\_\_\_.

**PRINCIPAL:** \_\_\_\_\_ **SURETY:** \_\_\_\_\_

By \_\_\_\_\_  
Signature

BY ATTORNEY-IN-FACT:

\_\_\_\_\_  
Official Capacity

\_\_\_\_\_  
Name

Attest: \_\_\_\_\_  
Corporation Secretary

\_\_\_\_\_  
Signature

\_\_\_\_\_  
Address

\_\_\_\_\_  
City State Zip

\_\_\_\_\_  
Phone Fax

**PART 6**  
**PERFORMANCE BOND FORM**  
**PAYMENT BOND FORM**

**PERFORMANCE BOND FORM**

Bond No. \_\_\_\_\_  
Solicitation \_\_\_\_\_  
Project Name: Miscellaneous Truss Repairs \_\_\_\_\_

\_\_\_\_\_ (Surety #1)      Bond Amount No. 1:      \$ \_\_\_\_\_  
\_\_\_\_\_ (Surety #2)\*      Bond Amount No. 2:\*      \$ \_\_\_\_\_  
• *If using multiple sureties*  
Total Penal Sum of Bond \$ \_\_\_\_\_

We, \_\_\_\_\_, as Principal, and the above identified Surety(ies), authorized to transact surety business in Oregon, as Surety, hereby jointly and severally bind ourselves, our respective heirs, executors, administrators, successors and assigns firmly by these presents to pay unto the Port of Hood River the sum of (Total Penal Sum of Bond) \_\_\_\_\_ (Provided, that we the Sureties bind ourselves in such sum "jointly and severally" as well as "severally" only for the purpose of allowing a joint action or actions against any or all of us, and for all other purposes each Surety binds itself, jointly and severally with the Principal, for the payment of such sum only as is set forth opposite the name of such surety), and

WHEREAS, the Principal has entered into a contract with the Port of Hood River, the plans, specifications, terms and conditions of which are contained in above-referenced Solicitation;

WHEREAS, the terms and conditions of the contract, together with applicable plans, standard specifications, special provisions, schedule of performance, and schedule of contract prices, are made a part of this Performance Bond by reference, whether or not attached to the contract (all hereafter called "Contract"); and

WHEREAS, the Principal has agreed to perform the Contract in accordance with the terms, conditions, requirements, plans and specifications, and all authorized modifications of the Contract which increase the amount of the work, the amount of the Contract, or constitute an authorized extension of the time for performance, notice of any such modifications hereby being waived by the Surety;

NOW, THEREFORE, THE CONDITION OF THIS BOND IS SUCH that if the Principal herein shall faithfully and truly observe and comply with the terms, conditions and provisions of the Contract, in all respects, and shall well and truly and fully do and perform all matters and things undertaken by Contractor to be performed under the Contract, upon the terms set forth therein, and within the time prescribed therein, or as extended as provided in the Contract, with or without notice to the Sureties, and shall indemnify and save harmless the Port of Hood River and members thereof, its officers, employees and agents, against any direct or indirect damages or claim of every kind and description that shall be suffered or claimed to be suffered in connection with or arising out of the performance of the Contract by the Principal or its subcontractors, and shall in all respects perform said Contract according to law, then this obligation is to be void; otherwise it shall remain in full force and effect.

Nonpayment of the bond premium will not invalidate this bond nor shall the Port of Hood River be obligated for the payment of any premiums.

This bond is given and received under authority of ORS Chapter 279C, the provisions of which hereby are incorporated into this bond and made a part thereof.

IN WITNESS WHEREOF, WE HAVE CAUSED THIS INSTRUMENT TO BE EXECUTED AND SEALED BY OUR DULY AUTHORIZED LEGAL REPRESENTATIVES:

Dated this \_\_\_\_\_ day of \_\_\_\_\_, 20\_\_\_\_\_.

**PRINCIPAL:** \_\_\_\_\_

By: \_\_\_\_\_  
Signature

\_\_\_\_\_  
Official Capacity

Attest: \_\_\_\_\_  
Corporation Secretary

**SURETY:** \_\_\_\_\_  
*[Add signatures for each if using multiple bonds]*

**BY ATTORNEY-IN-FACT:**  
*[Power-of-Attorney must accompany each bond]*

\_\_\_\_\_  
Name

\_\_\_\_\_  
Signature

\_\_\_\_\_  
Address

\_\_\_\_\_  
City State Zip

\_\_\_\_\_  
Phone Fax

**PAYMENT BOND FORM**

Bond No. \_\_\_\_\_  
Solicitation \_\_\_\_\_  
Project Name: Miscellaneous Truss Repairs \_\_\_\_\_

\_\_\_\_\_ (Surety #1)      Bond Amount No. 1:      \$ \_\_\_\_\_  
\_\_\_\_\_ (Surety #2)\*      Bond Amount No. 2:\*      \$ \_\_\_\_\_

- *If using multiple sureties*

Total Penal Sum of Bond \$ \_\_\_\_\_

We, \_\_\_\_\_, as Principal, and the above identified Surety(ies), authorized to transact surety business in Oregon, as Surety, hereby jointly and severally bind ourselves, our respective heirs, executors, administrators, successors and assigns firmly by these presents to pay unto the Port of Hood River the sum to (Total Penal Sum of Bond)

\_\_\_\_\_ (Provided, that we the Sureties bind ourselves in such sum "jointly and severally" as well as "severally" only for the purpose of allowing a joint action or actions against any or all of us, and for all other purposes each Surety binds itself, jointly and severally with the Principal, for the payment of such sum only as is set forth opposite the name of such surety), and

WHEREAS, the Principal has entered into a contract with the Port of Hood River, the plans, specifications, terms and conditions of which are contained in above-referenced Solicitation;

WHEREAS, the terms and conditions of the contract, together with applicable plans, standard specifications, special provisions, schedule of performance, and schedule of contract prices, are made a part of this Payment Bond by reference, whether or not attached to the contract (all hereafter called "Contract"); and

WHEREAS, the Principal has agreed to perform the Contract in accordance with the terms, conditions, requirements, plans and specifications, and schedule of contract prices which are set forth in the Contract and any attachments, and all authorized modifications of the Contract which increase the amount of the work, or the cost of the Contract, or constitute authorized extensions of time for performance of the Contract, notice of any such modifications hereby being waived by the Surety;

NOW, THEREFORE, THE CONDITION OF THIS BOND IS SUCH that if the Principal shall faithfully and truly observe and comply with the terms, conditions and provisions of the Contract, in all respects, and shall well and truly and fully do and perform all matters and things by it undertaken to be performed under said Contract and any duly authorized modifications that are made, upon the terms set forth therein, and within the time prescribed therein, or as extended therein as provided in the Contract, with or without notice to the Sureties, and shall indemnify and save harmless the Port of Hood River and members thereof, its officers, employees and agents, against any claim for direct or indirect damages of every kind and description that shall be suffered or claimed to be suffered in connection with or arising out of the performance of the Contract by the Contractor or its subcontractors, and shall promptly pay all persons supplying labor, materials or both to the Principal or its subcontractors for prosecution of the work provided in the Contract; and shall promptly pay all contributions due the State Industrial Accident Fund and the State Unemployment Compensation Fund from the Principal or its subcontractors in connection with the performance of the Contract; and shall pay over to the Oregon Department of Revenue all sums required to be deducted and retained from the wages of employees of the Principal and its subcontractors pursuant to ORS 316.167, and shall permit no lien nor claim to be filed or prosecuted against the Port of Hood River on account of any labor or materials furnished; and shall do all things required of the Principal by the laws of this State, then this obligation shall be void; otherwise, it shall remain in full force and effect.

Nonpayment of the bond premium will not invalidate this bond nor shall the Port of Hood River be obligated for the payment of any premiums.

This bond is given and received under authority of ORS Chapter 279C, the provisions of which hereby are incorporated into this bond and made a part thereof.

IN WITNESS WHEREOF, WE HAVE CAUSED THIS INSTRUMENT TO BE EXECUTED AND SEALED BY OUR DULY AUTHORIZED LEGAL REPRESENTATIVES:

Dated this \_\_\_\_\_ day of \_\_\_\_\_, 20\_\_\_\_\_.

**PRINCIPAL:** \_\_\_\_\_

By: \_\_\_\_\_  
Signature

\_\_\_\_\_  
Official Capacity

Attest: \_\_\_\_\_  
Corporation Secretary

**SURETY:** \_\_\_\_\_  
*[Add signatures for each if using multiple bonds]*

**BY ATTORNEY-IN-FACT:**  
*[Power-of-Attorney must accompany each bond]*

\_\_\_\_\_  
Name

\_\_\_\_\_  
Signature

\_\_\_\_\_  
Address

\_\_\_\_\_  
City State Zip

\_\_\_\_\_  
Phone Fax

**PART 7**  
**CERTIFICATE OF INSURANCE FORM**

**CERTIFICATE OF INSURANCE FORM**

This is to certify to: Port of Hood River, 1000 E. Port Marina Drive, Hood River OR 97031  
 That the following described policy or policies have been issued to:

\_\_\_\_\_  
 Name and Address of Insured

\_\_\_\_\_  
 Name and Address of Insurance Company

Description of Contract \_\_\_\_\_

Types of Coverages		Limits of Liability	Policy Number	Expiration Date
<b>1. Workers Compensation</b>		<b>Statutory</b>		
<b>2. Employer's Liability</b>		\$		
<b>3. Comprehensive General Liability</b>		<b>Bodily Injury</b>		<b>Property Damage</b>
	<b>A. Premises &amp; Operations</b>	\$		\$
	<b>B. Blanket Contractual</b>	\$		\$
	<b>C. Independent Sub-Contractors</b>	\$		\$
	<b>D. Products Liability &amp; Completed Operations</b>	\$		\$
<b>4. Comprehensive Automobile Liability (owner, hired, &amp; non-owned)</b>				
<b>5. Other-Builders Risk</b>				
<b>6. Jones Act and USLHWA Insurance</b>	<b>If applicable</b>			

Expires 12:01 Standard Time at the address of name insurance stated herein.

\*Indicate the following property liability features:

	<u>Yes</u>	<u>No</u>
1. "Broadform" including occurrence and care, custody and control.	___	___
2. Explosion, collapse and underground damage exclusions.	___	___

The insurer agrees that it will notify in writing, \_\_\_\_\_ of any material change, expiration or cancellation of the above-described policies not less than thirty (30) days before such change, expiration or cancellation becomes effective. It is further agreed the above named owner, his officers, agent (including his engineer) and employees are included as additional named insureds, but only as respects the performance of the above-described contract.

\_\_\_\_\_  
 Name of Insurance Company

\_\_\_\_\_  
 Authorized Representative



**PART 8**  
**GENERAL CONDITIONS (A-L)**

**PORT OF HOOD RIVER  
GENERAL CONDITIONS FOR PUBLIC WORKS CONTRACTS**

**SECTION A**  
General Provisions

**DEFINITION OF TERMS**

**Alternate** – One of two or more units of work or groups of bid items, identified separately in the proposal, from which Owner may make a choice between different methods or material of construction for performing the same work.

**Architect/Engineer**-person appointed by the Port to make drawings and specifications, and to provide contract administration of the Work contemplated by this Contract.

**Bid**-an offer in connection with an invitation to bid and a proposal in connection with a request for proposals.

**Bidder**-means an Offeror in connection with an invitation to bid and proposer in connection with a request for proposals.

**Change Order**-written order issued by the Port's Authorized Representative to the Contractor requiring a change in the Work within the general scope of the Contract Documents.

**Claim**-means a demand by Contractor for review of the denial of Contractor's initial request for an adjustment of the Contract terms, payment of money, extension of Contract Time or other relief.

**Contract**- the written agreement between the Port and the Contractor comprised of the Contract Documents which describe the Work to be done and the obligations between the parties.

**Contract Documents**-means the solicitation Documents and addenda thereto, the Port of Hood River Public Improvement Contract, General Conditions, Supplemental General Conditions, if any, the accepted Bid, Plans, Specifications, amendments and change orders.

**Contract Period**- as set forth in the Contract Documents, means the period of time beginning with the issuance of the Notice to Proceed and concluding upon Final Completion.

**Contract Price**- the total of the awarded Bid amount, as increased or decreased by the price of approved alternatives and change orders.

**Contract Time**-means any incremental period of time allowed under the Contract to complete any portion of the Work reflected in the project schedule.

**Contractor**-person awarded the Contract for Work contemplated.

**Days**-are calendar days, unless otherwise specified.

**Direct Costs**-means the costs of materials, including sales tax, cost of delivery; cost of labor, including social security, unemployment insurance, and fringe benefits required by agreement or custom; worker's compensation insurance; project specific insurance; bond premiums, rental cost of equipment, and machinery required for execution of the work; and the additional costs of field personnel directly attributable to the Work.

**Final Completion**-means completion of all requirements under the Contract, excluding Warranty Work, and the final payment and release of retainage.

**Force Majeure**-means an act, event or occurrence caused by fire, riot, war, acts of God, nature, sovereign, or public enemy, strikes, freight embargoes or any other act, event or occurrence that is beyond the control of the party to this Contract who is asserting Force Majeure.

**Notice to Proceed**-the official written notice from the Port stating that the Contractor is to proceed with the Work defined in the Contract Documents.

**Offer**-a bid in connection with an invitation to bid and a proposal in connection with a request for proposals.

**Offeror**-means a bidder in connection with an invitation to bid and proposer in connection with a request for proposals.

**Overhead**-those items which may be included in the Contractor's markup and that shall not be charged as Direct Cost of Work, including without limitation such Overhead expenses as wages or salary of personnel above the level of foreman and expenses of the Contractor's office at the job site including expenses of personnel staffing the job site office.

**Owner**-Port of Hood River.

**Owner's (Port's) Authorized Representative**-those individuals identified in writing by the Owner to act on behalf of the Owner for this project.

**Person**-an entity doing business as a sole proprietorship, a partnership, a joint venture, a corporation, a limited liability company or partnership, or any other entity possessing the legal capacity to contract.

**Plans**-the drawings which show the location, type, dimensions, and details of the Work to be done under this Contract.

**Punchlist**-the list of Work yet to be completed or deficiencies which need to be corrected in order to achieve Final Completion of the Contract.

**Record Document**-means the as-built Plans, Specifications, testing and inspection records, product test data, samples, manufacturer and distributor/supplier warranties evidencing transfer to Owner, operational and maintenance manuals, shop drawings, Change Orders, correspondence, certificates of occupancy, and other documents listed in section B of these General Conditions, recording all services performed.

**Solicitation Document**-means invitation to bid or request for proposal or request for quotes.

**Specification**-means any description of the physical or functional characteristics of the Work, or of the nature of a supply, service or construction item. Specifications may include a description of any requirement for inspecting, testing or preparing a supply, service or construction item for delivery and the quantities or qualities of materials to be furnished under the Contract. Specifications will generally state the results or products to be obtained and may describe the method and manner of doing the work to be performed.

**Subcontractor**- a person having a direct contract with the Contractor, or another subcontractor, to perform one or more items of the Work.

**Substantial Completion**-the date when the Owner accepts in writing the construction, alteration, or repair of the improvement to real property or any designated portion thereof as having reached the state of completion when it may be used or occupied for its intended purpose. Substantial Completion of facilities with operating systems occurs only after thirty (30) continuous days of successful, trouble-free operation.

**Substitutions**- items that in function, performance, reliability, quality, and general configuration are the same or better than the product specified.

**Supplemental General Conditions**-those conditions that remove from, add to, or modify these General Conditions.

**Work**- the furnishing of all materials, equipment, labor, transportation, services and incidentals necessary to successfully complete any individual item or the entire Contract and the carrying out of duties and obligations imposed by the Contract Documents.

**SCOPE OF WORK**

The work contemplated under this Contract includes all labor, materials, transportation, equipment and services for, and incidental to, the completion of all construction work in connection with the project described in the Contract Documents. The Contractor shall perform all Work necessary so that the project can be legally occupied and fully used for the intended use set forth in the Contract Documents.

**INTERPRETATION OF CONTRACT DOCUMENTS**

Unless otherwise specifically defined in the Contract Documents, words which have well-known technical meanings or construction industry meanings are used in the Contract Documents in accordance with such recognized meanings. Contract documents are intended to be complimentary. Whatever is called for in one, is interpreted to be called for in all. However, in the event of conflicts or discrepancies among Contract Documents, interpretations will be based on the following descending order of precedence:

1. Contract amendments and Change Orders, with those of later date having precedence over those of an earlier date;
2. The Port of Hood River Public Improvement Contract;
3. The Plans and Specifications;
4. The General Conditions;
5. The Solicitation Document and any addenda thereto;
6. The Accepted Offer.

In the case of an inconsistency between the Plans and Specifications or within either document not clarified by addendum, the better quality or greater quantity of Work shall be provided in accordance with the Owner or Owner's Authorized Representative's interpretation in writing.

If the Contractor finds discrepancies in or omissions from the Contract Documents, or if the Contractor is in doubt as to their meaning, the Contractor shall at once notify the Owner or the Owner's Authorized Representative. Matters concerning performance under, and interpretation of requirements of, the Contract Documents will be decided by the Owner's Authorized Representative, who may delegate that duty in some instances to the Architect/Engineer. Responses to the Contractor's request for interpretation of Contract Documents will be made in writing by the Owner's Authorized representative within any time limits agreed upon or otherwise with reasonable promptness. Interpretations and decisions of the Owner's Authorized Representative will be consistent with the intent of and reasonably inferable from the Contract Documents. Contractor shall not proceed without direction in writing from the Owner's Authorized Representative.

**EXAMINATION OF PLANS, SPECIFICATIONS, AND SITE**

It is understood that the Contractor, before submitting a bid, has made careful examination of the Contract Documents; has become fully informed as to the quality and quantity of materials and the character of the Work required; and has made a careful examination of the location and conditions of the Work and the sources of supply for materials. The Owner will in no case be responsible for any loss or for any unanticipated costs that may be suffered by the Contractor as a result of the Contractor's failure to acquire full information in advance in regard to all conditions pertaining to the Work.

**SECTION B**

Administration of the Contract

**PORT'S ADMINISTRATION OF THE CONTRACT**

The Port's Authorized Representative will provide administration of the Contract as described in the Contract documents (1) during construction, (2) until final payment is due and (3) during the one-year period for correction of work. The Port's Authorized Representative will act on behalf of the Port to the extent provided in the Contract Documents, unless modified in writing in accordance with other provisions of the contract. In performing these tasks, the Port may rely on the Architect/Engineer or other consultants to perform some or all of these tasks.

The Port's Authorized Representative will visit the site at intervals appropriate to the stage of the Contractor's operations (1) to become generally familiar with and to keep the Port informed about the

progress and quality of the portion of the Work completed, (2) to endeavor to guard the Port against defects and deficiencies in the Work, and (3) to determine in general if Work is being performed in a manner indicating that the Work, when fully completed will be in accordance with the Contract Documents.

The Port's Representative will neither have control over or charge of, nor be responsible for the construction means, methods, techniques, sequences or procedures, or for the safety precautions and programs in connection with the work.

Except as otherwise provided in the Contract Documents or when direct communications have been specifically authorized, the Port and Contractor shall endeavor to communicate with each other through the Port's Authorized Representative or designee about matters arising out of or relating to the contract. Communications by and with the Architect/Engineer's consultants shall be through the Architect/Engineer. Communications by and with Subcontractors and material suppliers shall be through the Contractor. Communications by and with separate contractors shall be through the Port's Authorized Representative.

Based on the Architect/Engineer's evaluation of the Contractor's Application for Payment, or unless otherwise stipulated by the Port's Authorized Representative, the Architect/Engineer will review and certify the amounts due the Contractor and will issue Certificates for Payments in such amounts.

### **CONTRACTOR'S MEAN AND METHODS; MITIGATION OF IMPACTS**

The Contractor shall direct and supervise the Work, using the Contractor's best skill and attention. The Contractor shall solely be responsible for and have control over construction means, methods, techniques, sequences and procedures and for coordinating all portions of the Work under this Contract, unless Contract Documents give other specific instructions concerning these matters. If the Contract Documents give specific instructions concerning construction means, methods, techniques, sequences or procedures, the Contractor shall evaluate the jobsite safety thereof and, except as stated below, shall be fully and solely responsible for the jobsite safety of such means, methods, techniques, sequences or procedures.

The contractor is responsible to protect and maintain the Work during the course of construction and to mitigate any adverse impacts to the project, including those caused by authorized changes, which may affect cost, schedule, or quality.

The Contractor is responsible for the actions of all its personnel, laborers, suppliers, and Subcontractors on the project. The Contractor shall enforce strict discipline and good order among Contractor's employees and other persons carrying out the Work. The Contractor shall not permit employment of persons who are unfit or unskilled for the tasks assigned to them.

### **MATERIALS AND WORKMANSHIP**

The intent of the Contract Documents is to provide for the construction and completion of every detail of the Work described. All Work shall be performed in a professional manner and unless the means or methods of performing a task are specified elsewhere in the Contract Documents, Contractor shall employ methods that are generally accepted and used by the industry, in accordance with industry standards.

The Contractor is responsible to perform the Work as required by the Contract Documents. Defective work shall be corrected at the Contractor's expense.

Work done and materials furnished shall be subject to inspection and/or observation by the Port's Authorized Representative to determine if they conform to the Contract Documents. Inspection of the Work by the Port's Authorized Representative does not relieve the Contractor of responsibility for the Work in accordance with the Contract Documents.

Contractor shall furnish adequate facilities, as required, for the Port's Authorized Representative to have safe access to the Work including without limitation walkways, railings, ladders, tunnels, and platforms. Producers, suppliers, and fabricators shall also provide facilities and access to their facilities.

The Contractor shall furnish Samples of Materials for testing by the Port's Authorized Representative and include the cost of the Samples in the Contract Price.

**PERMITS**

The United States Army Corps of Engineers does not require a nationwide permit for this work. No other State or Federal permits are required.

**COMPLIANCE WITH GOVERNMENT LAWS AND REGULATIONS**

Contractor shall comply with all federal, state and local laws, codes, regulations and ordinances applicable to the Work and Contract. Failure to comply with such requirements shall constitute a breach of contract and shall be grounds for Contract termination. Without limiting the generality of the foregoing, Contractor expressly agrees to comply with the following as applicable:

- i) Title VI and VII of Civil Rights act of 1964, as amended
- ii) Section 503 and 504 of the Rehabilitation act of 1973, as amended
- iii) The Health Insurance Portability and Accountability Act of 1996
- iv) The Americans with Disabilities Act of 1990, as amended
- v) ORS Chapter 659A, as amended
- vi) All regulations and administrative rules established pursuant to the foregoing laws
- vii) All other applicable requirements of federal and state civil rights and rehabilitations statues, rules and regulations.

Port's performance under the Contract is conditioned upon the Contractor's compliance with the provisions of ORS 279C.505, 279C.510, 279C.515, 279C.520, and 279C.530, which are incorporated by reference herein.

Contractor shall comply with all applicable requirements of federal and state civil rights and rehabilitation statues, rules and regulations; and

- (a) Contractor shall not discriminate against Disadvantaged, Minority, Women, or Emerging Small Business enterprises, as those terms are defined in ORS 200.005, in the awarding of subcontracts (ORS 279A.110)
- (b) Contractor shall maintain, in current and valid form, all licenses and certificates required by tax, regulation, or this Contract when performing the Work.

Unless contrary to federal law, Contractor shall certify that it shall not accept a bid from Subcontractors to perform Work as described in ORS 701.005 under this contract unless such Subcontractors are registered with the Construction Contractors Board in accordance with ORS 701.035 to 701.055 at any time they submit their bids to the Contractor.

Unless contrary to federal law, Contractor shall certify that each landscape contractor, as defined in ORS 671.520(2), performing Work this Contract holds a valid landscape contractor's license issued pursuant to ORS 671.560.

The following notice is applicable to Contractors who perform excavation Work. ATTENTION: Oregon law requires you to follow rules adopted by the Oregon Utility Notification Center. Those rules are set forth in OAR 952-001-0010 through OAR 952-001-0090. You may obtain copies of those rules by calling the center at (503)232-1987.

Failure to comply with any or all of the requirements set forth here shall be a breach of Contract and constitute grounds for Contract termination. Damages or costs resulting from such noncompliance shall be the responsibility of Contractor.

**COMPLIANCE WITH GRANT REQUIREMENTS** - (Not applicable)

**INSPECTION**

Port's Authorized Representative shall have access to the Work at all times.

The Port's Authorized Representative at its discretion will make inspection of Work. The Port's Authorized Representative will have authority to reject Work that does not conform to the Contract Documents. Any Work found to be not in conformance with the Contract Documents, in the discretion of the Port's Authorized Representative, shall be removed and replaced at the Contractor's expense.

Contractor shall make or obtain at the appropriate time all tests, inspections and approvals of portions of the Work required by the Contract Documents or by laws, ordinances, rules, regulations, or orders of public authorities having jurisdiction. Unless otherwise provided, the Contractor shall make arrangements for such tests, inspections and approvals with an independent testing laboratory or entity acceptable to the Port, or with the appropriate public authority, and shall bear all related costs of tests, inspections, and approvals. Tests or inspections conducted pursuant to the Contract Documents shall be made promptly to avoid unreasonable delay in the Work. The Contractor shall give the Port's Authorized Representative timely notice of when and where tests and inspections are to be made so that the Port's Authorized Representative may be present for such procedures. Required certificates of testing, inspection, or approval shall, unless otherwise required by the Contract Documents, be secured by the Contractor and promptly delivered to the Port's Authorized Representative.

Work done or materials used without inspection or testing by the Port's Authorized Representative may be ordered removed at the Contractor's expense.

If directed to do so at any time before the Work is accepted, the Contractor shall uncover portions of the completed Work for inspection. After inspection, the Contractor shall restore such portions of Work to the standard required by the Contract. If the Work uncovered is unacceptable or was done with sufficient notice to Port's Authorized Representative, the uncovering and restoration will be paid for as a Change Order.

If any testing or inspection reveals failure of the portions of the Work to comply with requirements established by the Contract Documents, all costs necessary by such failure, including those of repeated procedures and compensation for the Port's Authorized Representative and Architect/Engineer's services and expenses, shall be at the Contractor's expense.

#### **SEVERABILITY**

If any provision of this Contract is declared by a court to be illegal or in conflict with any law, the validity of the remaining terms and provisions shall not be affected and the rights and obligations of the parties shall be construed and enforced as if the Contract did not contain the particular provision held to be invalid.

#### **ACCESS TO RECORDS**

Contractor shall keep, at all times on the Work site, one record copy of the complete Contract Documents, including the Plans, Specifications, Change Orders and addenda, in good order and marked currently to record filed changes and selections made during construction, and one record copy of Shop Drawings, Product Data, Samples and similar submittals, and shall at all times give the Port's Authorized Representative access thereto.

Contractor shall retain and the Port and its duly Authorized Representatives shall have access to, for a period not less than six (6) years, all Record Documents, financial and accounting records, and other books, documents, papers and records of Contractor which are pertinent to the Contract including record pertaining to Overhead and indirect costs, for the purpose of audit, examination, excerpts and transcripts. If for any reason, any part of the Contract is involved in litigation, Contractor shall retain all such records until all litigation is resolved. The Port and/or its agents shall continue to be provided full access to the records during litigation.

#### **WAIVER**

Failure of the Port to enforce any provision of this Contract shall not constitute a waiver or relinquishment by the Port of the right to such performance in the future nor the right to enforce any other provision of this Contract.

#### **SUBCONTRACTS AND ASSIGNMENT**

Contractor shall require each Subcontractor, to the extent of the Work to be performed by the Subcontractor, to be bound by the terms and conditions of these General Conditions, and to assume toward the Contractor all of the obligations and responsibilities which the Contractor assumes toward the Port thereunder, unless,

- (1) the same are clearly inapplicable to the subcontractor at issue because of legal requirements or industry practices, or

(2) specific exceptions are requested by Contractor and approved in writing by Port.

Where appropriate, Contractor shall require each subcontractor to enter in similar agreements with sub-subcontractors at any level.

At Port's request, Contractor shall submit to Port prior to their execution either Contractor's form of subcontract, or the subcontract to be executed with any particular Subcontractor. If Port disapproves such form, Contractor shall not execute the form until the matters disapproved are resolved to Port's satisfaction. Port's review, comment upon or approval of any such form shall not relieve Contractor of its obligations under this Agreement or be deemed a waiver of such obligations of Contractor.

Contractor shall not assign, sell or transfer its rights, or delegate its responsibilities under this Contract, in whole or part, without the prior written approval of the Port. No such written approval shall relieve Contractor of any obligations of this Contract, and any transferee shall be considered the agent of the Contractor and bound to perform in accordance with the Contract Documents. Contractor shall remain liable as between the original parties to the Contract as if no assignment had occurred.

### **SUCCESSORS IN INTEREST**

The provisions of this Contract shall be binding upon and shall accrue to the benefit of the parties to this Contract and their respective permitted successors and assigns.

### **PORT'S RIGHT TO DO WORK**

Port reserves the right to perform other or additional work at or near the project site with other forces than those of the Contractor. If such work takes place within or next to the project site, Contractor will coordinate with all other contractors or forces, carry out the Work in a way that will minimize interference and delay for all forces involved, place and dispose of materials being used so as not to interfere with the operations of another, and join the Work with the work of others in an acceptable manner and perform it in proper sequences to that of the others. The Port's Authorized Representative will resolve any disagreements that may arise between or among Contractor and the other contractors over the method or order of doing all work (including the Work). In case of unavoidable interference, Port's Authorized Representative will establish work priority (including the Work), which generally will be in the sequence that the contracts were awarded.

### **OTHER CONTRACTS**

In all cases and at any time, the Port has the right to execute other contracts related to or unrelated to the Work of this Contract. The Contractor of this Contract will fully cooperate with any and all other contractors without additional cost to the Port in the manner described above.

### **LITIGATION**

Any claims between Port and Contractor that arises from or related to this Contract and that is not resolved through the Port contract review board shall be brought and conducted solely and exclusively within the Circuit Court of Hood River County.

### **ALLOWANCES**

The contractor shall include in the Contract Price all allowances stated in the Contract Documents. Items covered by allowances shall be supplied for such amounts and by such persons or entities as the Port may direct.

Unless otherwise provided in the Contract Documents:

- a. When finally reconciled, allowances shall cover the cost to the Contractor of materials and equipment delivered at the site and all required taxes, less applicable trade discounts;
- b. Contractor's cost for unloading and handling at the site, labor, installation costs, Overhead, profit and other expenses contemplated for stated allowance amounts shall be included in the Contract Price but not in the allowances;



- c. Whenever costs are more than or less than allowances, the Contract Price shall be adjusted accordingly by Change Order. The amount of the Change Order shall reflect (1) the difference between actual costs and the allowances under Section (b) and (2) changes in Contractor's costs under this Section.
- d. Unless Port requests otherwise, Contractor shall provide to Port a proposed fixed price for any allowance work prior to its performance.

### **SUBMITTALS, SHOP DRAWINGS, PRODUCT DATA AND SAMPLES**

Design Build requirements apply. The Contractor shall prepare and keep current, for the Architect's/Engineer's approval (or for the approval of Port's Authorized Representative if approval authority has not been delegated to the Architect/Engineer), a schedule and list of submittals which is coordinated with the Contractor's construction schedule and allows the Architect/Engineer reasonable time to review submittals. Port reserves the right to finally approve the schedule and list of submittals. Submittals include, without limitation, Shop Drawings, Product Data, and Samples which are described below:

- a. Shop Drawings are drawings, diagrams, schedules and other data specially prepared for the Work by the Contractor or a Subcontractor (including any sub-subcontractor), manufacturer, supplier or distributor to illustrate some portion of the Work.
- b. Product Data are illustrations, standard schedules, performance charts, instructions, brochures, diagrams and other information furnished by the Contractor to illustrate materials or equipment for some portion of the Work.
- c. Samples are physical examples which illustrate materials, equipment or workmanship and establish standards by which the Work will be judged.

Shop Drawings, Product Data, Samples and similar submittals are not Contract Documents. The purpose of their submittal is to demonstrate for those portions of the Work for which submittals are required by the Contract Documents the way by which the Contractor proposes to conform to the information given and the design concept expressed in the Contract Documents the way by which the Contractor proposes to conform to the information given and the design concept expressed in the Contract Documents. Review of submittals by the Architect/Engineer is not conducted for the purpose of determining the accuracy and completeness of other details such as dimensions and quantities, or for substantiating instructions for installation or performance of equipment or systems, or for approval of safety precautions or, unless otherwise specifically stated by the Architect/Engineer, of any construction means, methods, techniques, sequences or procedures, all of which remain the responsibility of the Contractor as required by the Contract Documents. The Architect/Engineer's review of the Contractor's submittals shall not relieve the Contractor of its obligations under the Contract Documents. The Architect/Engineer's approval of a specific item shall not indicate approval of an assembly of which the item is a component. Informational submittals upon which the Architect/Engineer is not expected to take responsive action may be so identified in the Contract Documents. Submittals which are not required by the Contract Documents may be returned by the Architect/Engineer without action.

The Contractor shall review for compliance with the Contract Documents, approve and submit to the Architect/Engineer Shop Drawings, Product Data, Samples and similar submittals required by the Contract Documents with reasonable promptness and in such sequence as to cause no delay in the Work or in the activities of the Port or of separate contractors. Submittals which are not marked as reviewed for compliance with the Contract Documents and approved by the Contractor may be returned by the Architect/Engineer without action.

By approving and submitting Shop Drawings, Product Data, Samples and similar submittals, the Contractor represents that the Contractor has determined and verified materials, field measurements and field construction criteria related thereto, or will do so, and has checked and coordinated the information contained within such submittals with the requirements of the Work and of the Contract Documents.

The Contractor shall perform no portion of the Work for which the Contract Documents require submittal and review of Shop Drawings, Product Data, Samples or similar submittals until the respective submittal has been approved by the Architect/Engineer.

The Work shall be in accordance with approved submittals except that the Contractor shall not be relieved of responsibility for deviations from requirements of the Contract Documents by the Architect/Engineer's review

or approval of Shop Drawings, Product Data, Samples or similar submittals unless the Contractor has specifically informed the Architect/Engineer in writing of such deviation at the time of submittal and (1) the Architect/Engineer has given written approval to the specific deviation as a minor change in the Work, or (2) a Change Order has been executed by Port authorizing the deviation. The Contractor shall not be relieved of responsibility for errors or omissions in Shop Drawings, Product Data, Samples or similar submittals by the Architect/Engineer's review or approval thereof.

If any errors or omissions appear in the drawings, specifications or other documents the Contractor shall, immediately and before proceeding with that portion of the work affected, notify Owner or such error or omission. Should the Contractor proceed with erroneous work without giving notice, Contractor shall be responsible for errors and make required corrections without additional cost to Owner.

### **SUBSTITUTIONS**

The Contractor may make Substitutions only with the consent of the Port, after evaluation by the Port's Authorized Representative and only in accordance with a Change Order. Substitutions shall be subject to the requirements of the bid documents. By making requests for Substitutions, the Contractor will provide the same warranty for the Substitution that the Contractor would for the product originally specified unless approved otherwise; certifies that the cost data presented is complete and includes all related costs under this Contract including redesign costs, and waives all claims for additional costs related to the Substitution which subsequently becomes apparent; and will coordinate the installation of the accepted Substitution, making such changes as may be required for the Work to be completed in all respects.

### **USE OF PLANS AND SPECIFICATIONS**

Plans, Specifications and related Contract Documents furnished to Contractor by Port or Port's Architect/Engineer shall be used solely for the performance of the Work under this Contract. Contractor and its Subcontractors and suppliers are authorized to use and reproduce applicable portions of such documents appropriate to the execution of the Work, but shall not claim ownership or other interest in them beyond the scope of this Contract, and no such interest shall attach. Unless otherwise indicated, all common law, statutory and other reserved rights, in addition to copyrights, are retained by Port.

### **FUNDS AVAILABLE AND AUTHORIZED**

Port reasonably believes at the time of entering into this Contract that sufficient funds are available and authorized for expenditure to finance the cost of this Contract within the Port's appropriation or limitation. Contractor understands and agrees that, to the extent that sufficient funds are not available and authorized for expenditure to finance the cost of this Contract, Port's Services performed after the last day of the current biennium is contingent on Port receiving from the Oregon Legislative Assembly appropriations, limitations or other expenditure authority sufficient to allow Port, in the exercise of its reasonable administrative discretion, to continue to make payments under this Contract.

### **NO THIRD PARTY BENEFICIARIES**

Port and Contractor are the only parties to this Contract and are the only parties entitled to enforce its terms. Nothing in this Contract gives, is intended to give, or shall be construed to give or provide any benefit or right, whether directly, indirectly, or otherwise, to third persons unless such third persons are individually identified by name herein and expressly described as intended beneficiaries of the terms of this Contract.

## **SECTION C**

### **Wages & Labor**

### **MINIMUM WAGE RATES ON PUBLIC WORKS**

Contractor shall comply fully with the provisions of ORS 279C.800 through 279C.870. Documents establishing those conditions, as determined by the Commissioner of the Bureau of Labor and Industries (BOLI), are included as attachments to or are incorporated by reference in the Contract Documents. Contractor shall pay workers at not less than the specified minimum hourly rate of wage, and shall include that requirement in all subcontracts.

### **INTENT TO PAY PREVAILING WAGE**

Approved Intent to Pay Prevailing Wage statements shall be provided to Owner prior to first pay application.

**PAYROLL CERTIFICATION; ADDITIONAL RETAINAGE; FEE REQUIREMENTS**

In accordance with ORS 279C.845, the Contractor and every Subcontractor shall submit written certified statements to the Port's Authorized Representative, on the form prescribed by the Commissioner of the Bureau of Labor and Industries, certifying the hourly rate of wage paid each worker which the Contractor or the Subcontractor has employed on the project and further certifying that no worker employed on the project has been paid less than the prevailing rate of wage or less than the minimum hourly rate of wage specified in the Contract, which certificate and statement shall be verified by the oath of the Contractor or the Subcontractor has read such statement and certificate and knows the contents thereof and that the same is true to the Contractor or Subcontractor's best knowledge and belief. The certified statements shall set out accurately and completely the payroll records for the prior week including the name and address of each worker, the worker's correct classification, rate of pay, daily and weekly number of hours worked, deductions made and actual wages paid. Certified statements for each week during which the Contractor or Subcontractor has employed a worker on the project shall be submitted once a month, by the fifth business day of the following month.

The Contractor and Subcontractors shall preserve the certified statements for a period of six (6) years from the date of completion of the Contract.

Pursuant to ORS 279C.845(7), the Port shall retain 25 percent of any amount earned by the Contractor on this public works project until the Contractor has filed the certified statements required by previous paragraphs. The Port shall pay to the Contractor the amount retained under this subsection within 14 days after the Contractor files the required certified statements, regardless of whether a Subcontractor has failed to file certified statements.

Pursuant to ORS 279C.845(8), the Contractor shall retain 25 percent of any amount earned by a first-tier Subcontractor on this public works project until the first-tier Subcontractor has filed with the Port the certified statements required by previous section. Before paying any amount retained under this subsection, the Contractor shall verify that the first-tier Subcontractor has filed the certified statement, Within 14 days after the first-tier Subcontractor files the required certified statement the Contractor shall pay the first-tier Subcontractor any amount retained under this subsection.

In accordance with statutory requirements, and administrative rules promulgated by the Commissioner of the Bureau of Labor and Industries, the fee required by ORS 279C.825(1) will be paid by Port to the Commissioner at the time Port enters into the Contract.

**PROMPT PAYMENT AND CONTRACT CONDITIONS**

Pursuant to ORS 279C.505 and as a condition to Port's performance hereunder, the Contractor shall:

- Make payment promptly, as due, to all persons supplying to Contractor labor or materials for the prosecution of the Work provided for in this Contract.
- Pay all contributions or amounts due the State Industrial Accident Fund from such Contractor or Subcontractor incurred in the performance of the Contract.
- Not permit any lien or claim to be filed or prosecuted against the Port on account of any labor or material furnished. Contractor will not assign any claims that Contractor has against Port, or assign any sums due by Port, to Subcontractors, suppliers, or manufacturers, and will not make any agreement or act in any way to give Subcontractors a claim or standing to make a claim against the Port.
- Pay to the Department of Revenue all sums withheld from employees pursuant to ORS 316.167.
- Demonstrate that an employee drug testing program is in place as follows:
  - (a) Contractor represents and warrants that Contractor has in place at the time of the execution of this Contract, and shall maintain during the term of this Contract, a Qualifying Employee Drug Testing Program for its employees that includes, at a minimum, the following:
    - (1.) A written employee drug testing policy,
    - (2.) Required drug testing for all new Subject Employees or, alternatively, required testing of all Subject Employees every 12 months on a random selection basis, and
    - (3.) Required testing of a Subject Employee when the Contractor has reasonable cause to believe the Subject Employee is under the influence of drugs.

A drug testing program that meets the above requirements will be deemed a "Qualifying Employee Drug Testing Program." For the purposes of this section, an employee is a "Subject Employee" only if that employee will be working on the project job site.

(b) Contractor shall require each Subcontractor providing labor for the project to:

- (1.) Demonstrate to the Contractor that it has a Qualifying Employee Drug Testing Program for the Subcontractor's Subject Employees, and represent and warrant to the Contractor that the Qualifying Employee Drug Testing Program is in place at the time of subcontract execution and will continue in full force and effect for the duration of the subcontract, or
- (2.) Require that the Subcontractor's Subject Employees participate in the Contractor's Qualifying Employee Drug Testing Program for the duration of the subcontract.

Pursuant to ORS 279C.515, and as a condition to Port's performance hereunder, Contractor agrees:

- If Contractor fails, neglects or refuses to make prompt payment of any claim for labor or services furnished to the Contractor of a Subcontractor by any person in connection with the project as such claim becomes due, the proper officer(s) representing the Port may pay the claim and charge the amount of the payment against funds due or to become due to Contractor under this Contract. Payment of claims in this manner shall not relieve the Contractor or the Contractor's surety from obligation with respect to any unpaid claims.
- If the Contractor or a first-tier Subcontractor fails, neglects or refuses to make payment to a person furnishing labor or materials in connection with the public contract for a public improvement within thirty (30) days after receipt of payment from Port or a contractor, the Contractor or first-tier Subcontractor shall owe the person the amount due plus interest charges commencing at the end of the 10-Day period that payment is due under ORS 279C.580(3) and ending upon final payment, unless payment is subject to a good faith dispute as defined in ORS 279C.580. The rate of interest charged to the Contractor or first-tier Subcontractor on the amount due shall equal three times the discount rate on 90-Day commercial paper in effect at the Federal Reserve Bank in the Federal Reserve district that includes Oregon on the date that is thirty (30) days after the date when payment was received from Port or from the Contractor, but the rate of interest shall not exceed thirty (30) percent. The amount of interest may not be waived.
- If the Contractor or a Subcontractor fails, neglects or refuses to make payment to a person furnishing labor or materials in connection with the Contract, the person may file a complaint with the Construction Contractors Board, unless payment is subject to a good faith dispute as defined in ORS 279C.580. Every contract related to this Contract shall contain a similar clause.

Pursuant to ORS 279C.580, Contractor shall include in each subcontract for property or services entered into by the Contractor and a first-tier Subcontractor, including a material supplier, for the purpose of performing a construction contract:

- (a) A payment clause that obligates the Contractor to pay the first-tier Subcontractor for satisfactory performance under its subcontract within ten (10) days out of such amounts as are paid to the Contractor by Port under the Contract;
- (b) An interest penalty clause that obligates the Contractor if payment is not made within thirty (30) days after receipt of payment from Port, to pay to the first-tier Subcontractor an interest penalty on amounts due in the case of each payment not made in accordance with the payment clause included in the subcontract pursuant to paragraph (a) of this subsection. Contractor or first-tier Subcontractor shall not be obligated to pay an interest penalty if the only reason that the Contractor or first-tier Subcontractor did not make payment when payment was due is that the Contractor or first-tier Subcontractor did not receive payment from Port or Contractor when payment was due. The interest penalty shall be for the period beginning on the day after the required payment date and ending on the date on which payment of the amount due is made; and shall be computed at the rate specified in ORS 279C.515(2).
- (c) A clause which requires each of Contractor's Subcontractor's to include, in each of their contracts with lower-tier Subcontractors or suppliers, provisions to the effect that the first-tier Subcontractor shall pay its lower-tier Subcontractors and suppliers in accordance with the provisions of subsections

(a) and (b), above and requiring each of their Subcontractors and suppliers to include such clauses in their subcontracts and supply contracts.

All employers, including Contractor, that employ subject workers who work under this Contract in the State of Oregon shall comply with ORS 656.017 and provide the required Workers' Compensation coverage, unless such employers are exempt under ORS 656.126. Contractor shall ensure that each of its Subcontractors complies with these requirements.

#### **PAYMENT FOR MEDICAL CARE**

Pursuant to ORS 279C.530, and as a condition to Port's performance hereunder, Contractor shall promptly, as due, make payment to any person, partnership, association or corporation furnishing medical, surgical, and hospital care or other needed care and attention, incident to sickness or injury, to the employees of such Contractor, all sums of which the Contractor agrees to pay for such service and all moneys and sums which the Contractor has collected or deducted from the wages of personnel pursuant to any law, contract or agreement for the purpose of providing or paying for such services.

#### **HOURS OF LABOR**

As a condition to Port's performance hereunder, Contractor shall comply with ORS 279C.520, as amended from time to time and incorporated herein by this reference. Contractor shall give a written schedule to employees showing the number of hours per day and days per week the employee may be required to work. Pursuant to ORS 279C.520 and as a condition to Port's performance hereunder, no person shall be employed to perform Work under this Contract for more than ten (10) hours in any day of forty (40) in any one week, except in cases of necessity, emergency or where public policy absolutely requires it. In such instances, Contractor shall pay the employee at least time and a half pay:

- (a) For all overtime in excess of eight (8) hours a day or forty (40) hours in any one week when the work week is five consecutive days, Monday through Friday, or
- (b) For all overtime in excess of ten (10) hours a day or forty hours (40) in any one week when the work week is four consecutive days Monday through Friday; and
- (c) For all Work performed on Saturday and on any legal holidays specified in ORS 279C.540.

This section will not apply to Contractor's Work under this Contract if Contractor is currently a party to a collective bargaining agreement with any labor organization.

This section shall not excuse Contractor from completion of the Work within the time required under this Contract.

### **SECTION D** Changes in Work

#### **CHANGES IN WORK**

The terms of the Contract shall not be waived, altered, modified, supplemented or amended in any manner whatsoever without prior written approval of the Port's Authorized Representative, and then only in a manner consistent with the Change Order provisions of this conditions and after any necessary approvals required by public contracting laws have been obtained. Otherwise, a formal contract amendment is required, which shall not be effective until its execution by the parties to this Contract and all approvals required by public contracting laws have been obtained.

It is mutually agreed that changes in Plans, quantities, or details of construction are inherent in the nature of construction and may be necessary or desirable during the course of construction. Within the general scope of this Contract, the Port's Authorized Representative may at any time, without notice to sureties and without impairing the Contract, require changes consistent with this section. All Change Order Work shall be executed under the conditions of the Contract Document. Such changes may include, but are not limited to:

- (a) Modifications of specifications and design.
- (b) Increases or decreases in quantities.
- (c) Increases or decreases to the amount of Work.
- (d) Addition or elimination of any Work item.
- (e) Changes in the duration of the project.

- (f) Acceleration or delay in performance of Work.
- (g) Deductive changes.

Deductive changes are those made that reduce the scope of the Work, and shall be made by mutual agreement whenever feasible. In cases of suspension or partial termination under section I, "Termination or Suspension" to follow, Port reserves the right to unilaterally impose a deductive change and to self perform such Work, for which the provisions of "Port's Right to Do Work" shall then apply.

Adjustments in compensation shall be made under the conditions following, in which costs for deductive changes shall be based upon Direct Costs adjustments together with the related percentage markup specified for profit, Overhead and other indirect costs, unless otherwise agreed to by Port.

The Port and Contractor agree that Change Order Work shall be administered and compensated according to the following:

- (a) Unit pricing may be utilized at the Port's option when unit prices or solicitation alternatives were provided that established the cost for additional Work, and a binding obligation exists under the Contract on the parties covering the terms and conditions of the additional work.
- (b) If the Port elects not to utilize the unit pricing, or if in the event that unit pricing is not available or appropriate, fixed pricing may be used for Change Work Order. In fixed pricing the basis of payments or total price shall be agreed upon in writing between the parties to the Contract, and shall be established before the Work is done whenever feasible. The mark-ups set forth following shall be utilized by the parties as a guide in establishing fixed pricing, and will not be exceeded by Port without adequate justification. Cost and price data relating to Change Orders shall be supplied by Contractor to Port upon request, but Port shall be under no obligation to make such requests.
- (c) In the event that unit pricing and fixed pricing are not utilized, then the Change Order Work shall be performed on a cost reimbursement basis for Direct Costs. Such work shall be compensated on the basis of the actual, reasonable and allowable cost of labor, equipment, and material furnished on the Work performed. In addition, the following mark-ups shall be added to the Contractor's or Subcontractor's Direct Costs as full compensation for profit, Overhead and other indirect costs for Work directly performed with the Contractor's or Subcontractor's own forces:

On labor .....15%  
 On Equipment..10%  
 On Materials.....10%

When Change Order Work is invoiced by an authorized subcontractor at any level, each ascending tier Subcontractor or Contractor will be allowed a supplemental mark-up on each piece of subcontract Work covered by such change Order as follows:

\$0.00-\$5,000.00	10%, and then
over \$5,000.00	5%

Payments made to Contractor shall be complete compensation for Overhead, profit, and all costs that were incurred by the Contractor or by other forces furnished by the Contractor, including Subcontractors, for Change Order Work. Port may establish a maximum cost for Change Order Work under this section which shall not be exceeded for reimbursement without additional written authorization from Port. Contractor shall not be required to complete such Change Order Work without additional authorization.

Any necessary adjustments of Contract Time that may be required as a result of a Change Order must be agreed upon by the parties before the start of the Change Order Work unless Port's Authorized Representative authorizes Contractor to start the work before agreement on Contract Time adjustment. Contractor shall submit any request for additional compensation and additional contract time as soon as possible but no later than thirty (30) Days after receipt of the Change Order. If not received within the time limit, Contractor's requests pertaining to that Change Order are barred. The thirty day time limit applies to claims of Subcontractors, suppliers, or manufacturers that may be affected by the Change Order.

If Port's Authorized Representative denies the Contractor's request for additional compensation or adjustment of Contract Time, the Contractor may proceed to file a claim under the Claims Review Process described hereafter in this Section D.

No request or claim by the Contractor for additional cost or an extension of Contract Time shall be allowed if made after receipt of final payment application under this Contract. Contractor agrees to submit its final payment application within ninety (90) days after Substantial Completion, unless Port grants a written extension. Contractor shall not delay final payment application for any reason.

### **DELAYS**

Delays in construction include "Avoidable Delays", which are defined in the following section, and "Unavoidable Delays", which are defined in the one after. Found in this section are the effects of Avoidable Delays and Unavoidable Delays.

Avoidable Delays include any delays other than Unavoidable Delays, and include delays that otherwise would be considered Unavoidable Delays but that:

- (a) Could have been avoided by the exercise of care, prudence, foresight, and diligence on the part of the Contractor or its Subcontractors.
- (b) Affect only a portion of the Work and do not necessarily prevent or delay the prosecution of neither other parts of the Work nor the completion of the whole Work within the Contract Time.
- (c) Do not impact activities on the accepted critical path schedule.
- (d) Are associated with the reasonable interference of other contractors employed by the Port that do not necessarily prevent the completion of the whole Work within the Contract Time.

Unavoidable Delays include delays other than Avoidable delays that are:

- (a) Caused by any actions of the Port, Port's Authorized Representative, or any other employee or agent of the Port, or by separate contractor employed by the Port.
- (b) Caused by any site conditions which differ materially from what was represented in the Contract Documents or from conditions that would normally be expected to exist and be inherent to the construction activities defined in the Contract Documents. The Contractor shall notify the Port's Authorized Representative immediately of differing site conditions before the area has been disturbed. The Port's Authorized Representative will investigate the area and make a determination as to whether or not the conditions differ materially from either the conditions stated in the Contract Documents or those which could reasonably be expected in execution of this particular contract. If Contractor and the Port's Authorized Representative agree that a differing site condition exists, any additional compensation or additional Contract Time will be determined based on the process set forth in previous sections for Change Order Work. If the Port's Authorized Representative disagrees that a differing site condition exists and denies Contractor's request for additional compensation or Contract Time, Contractor may proceed to file a Claim under re: *Claims Review Process*. (following section)
- (c) Caused by Force Majeure acts, events or occurrences that could not have been avoided by the exercise of care, prudence, foresight, and diligence on the part of the Contractor or its Subcontractors.
- (d) Caused by adverse weather conditions. Any adverse weather conditions must be substantiated by documentary evidence that weather conditions were abnormal for the specific time period claimed, could not have been anticipated by the Contractor, and adversely impacted the project in a manner that could not be avoided by rescheduling the Work or by implementing measures to protect against the weather so that the Work could proceed. A rain, windstorm, high water, or other natural phenomenon for the specific locality of the Work, which might reasonably have been anticipated from the previous 10-year historical records of the general locality of the Work, shall not be construed as abnormal. The parties agree that rainfall greater than the following levels cannot be reasonably anticipated:
  - a. Daily rainfall equal to, or greater than, 0.50 inch during a month when the monthly rainfall exceeds the normal monthly average by twenty-five percent (25%) or more.
  - b. Daily rainfall equal to, or greater than, 0.75 inch at any time.

The Office of the Environmental Data Service of the National Oceanic and Atmospheric Administration of the U.S. Department of Commerce nearest the project site shall be considered the official agency of record for weather information.

Except as otherwise provided in ORS 279C.315, Contractor shall not be entitled to additional compensation or additional Contract Time for Avoidable Delays.

In the event of Unavoidable Delays, based on principles of equitable adjustment, Contractor may be entitled to the following:

- (a) Contractor may be entitled to additional compensation or additional Contract Time, or both, for Unavoidable Delays described earlier in section.
- (b) Contractor may be entitled to additional Contract Time for Unavoidable Delays described in previous section.

In the event of any requests for additional compensation or additional Contract Time, or both, as applicable, arising under this section for Unavoidable Delays, other than requests for additional compensation or additional Contract Time for differing site conditions for which a review process is established under previous section, Contractor shall submit a written notification of the delay to the Port's Authorized Representative within two (2) days of the occurrence of the cause of the delay. This written notification shall state the cause of the potential delay, the project components impacted by the delay, and the anticipated additional Contract Time or the additional compensation, or both, as applicable, resulting from the delay. Within seven (7) days after the cause of the delay has been mitigated, or in no case more than thirty (30) days after the initial written notification, the Contractor shall submit to the Port's Authorized Representative, a complete and detailed request for additional compensation or additional Contract Time, or both, as applicable, resulting from the delay. If the Port's Authorized Representative denies Contractor's request for additional compensation or adjustment of Contract Time, the Contractor may proceed to file a Claim under the following section, *Claims Review Process*.

If Contractor does not timely submit the notices required under this section, then unless otherwise prohibited by law, Contractor's Claim shall be barred.

### **CLAIMS REVIEW PROCESS**

All Contractor Claims shall be referred to the Port's Authorized Representative for review. Contractor's Claims, including Claims for additional compensation or additional Contract Time, shall be submitted in writing by Contractor to the Port's Authorized Representative within five (5) days after a denial of Contractor's initial request for an adjustment of Contract terms, payment of money, extension of Contract Time or other relief, provided that such initial request has been submitted in accordance with the requirements and within the time limits established in these General Conditions. Within thirty (30) days after the initial Claim, Contractor shall submit to the Port's Authorized Representative, a complete and detailed description of the Claim (the "Detailed Notice") that includes all information required by the following section. Unless the Claim is made in accordance with these time requirements, it shall be waived.

The Detailed Notice of the Claim shall be submitted in writing by Contractor and shall include a detailed, factual statement of the basis of the Claim, pertinent dates, Contract provisions which support or allow the Claim, reference to or copies of any documents which support the Claim, the dollar value of the Claim, and the Contract Time extension requested for the Claim. If the Claim involves Work to be completed by Subcontractors, the Contractor will analyze and evaluate the merits of the Subcontractor claim prior to forwarding it and that analysis and evaluation to the Port's Authorized Representative. The Port's Authorized Representative and the Port will not consider direct claims from Subcontractors, suppliers, manufacturers, or others not a party to this Contract. Contractor agrees that it will make no agreement, covenant, or assignment, nor will it commit any other act that will permit or assist any Subcontractor, supplier, manufacturer, or other to directly or indirectly make a claim against Port.

The Port's Authorized Representative will review all claims and take one or more of the following preliminary actions within ten (10) days of receipt of the Detailed Notice of a Claim: (1) request additional supporting information from the Contractor; (2) inform the Contractor and Port in writing of the time required for adequate review and response; (3) reject the Claim in whole or in part and identify the reasons for rejection;



(4) based on principles of equitable adjustment, recommend approval of all or part of the Claim; or (5) propose an alternate resolution.

The Port's Authorized Representative's decision shall be final and binding on the Contractor unless appealed by written notice to the Port within fifteen (15) days of receipt of the decision. The Contractor must present written documentation supporting the Claim within fifteen (15) days of the notice of appeal. After receiving the appeal documentation, the Port shall review the materials and render a decision within thirty (30) days after receiving the appeal documents.

The decision of the Port shall be final and binding unless the Contractor delivers to the Port its requests for mediation, which shall be a non-binding process, within fifteen (15) days of the date of the Port's decision. The mediation process will be considered to have commenced as of the date the Contractor delivers the request. Both parties acknowledge and agree that participation in mediation is a prerequisite to commencement of litigation of any disputes relating to the Contract. Both parties further agree to exercise their best efforts in good faith to resolve all disputes within sixty (60) days of the commencement of the mediation through the mediation process set forth herein.

In the event that a lawsuit must be filed within this sixty (60) day period in order to preserve a cause of action, the parties agree that notwithstanding the filing, they shall proceed diligently with the mediation to its conclusion prior to actively prosecuting the lawsuit, and shall seek from the Court in which the lawsuit is pending such stays or extensions, including the filing of an answer, as may be necessary to facilitate the mediation process. Further, in the event settlements are reached on any issues through the mediation, the parties agree to promptly submit the appropriate motions and orders documenting the settlement to the Court for its signature and filing.

The mediator shall be an individual mutually acceptable to both parties, but in the absence of agreement each party shall select a temporary mediator and the temporary mediators shall jointly select the permanent mediator. Each party shall pay its own costs for the time and effort involved in mediation. The cost of the mediator shall be split equally between the two parties. Both parties agree to exercise their best effort in good faith to resolve all disputes in mediation. Participation in mediation is a mandatory requirement of both the Port and the Contractor. The schedule, time and place for mediation will be mutually acceptable, or, failing mutual agreement, shall be as established by the mediator. The parties agree to comply with Port's mediation, if any, and shall execute all necessary documents to give effect to such confidentiality rules. In any event, the parties shall not subpoena the mediator or otherwise require the mediator to produce records, notes or work product, or to testify in any future proceedings as to information disclosed or representations made in the course of mediation, except to the extent disclosure is required by law.

Unless otherwise directed by Port's Authorized Representative, Contractor shall proceed with the Work while any Claim of Contractor is pending, including a Claim for additional compensation or additional Contract Time resulting from Change Order Work. Regardless of the review period or the final decision of the Port's Authorized Representative, the Contractor shall continue to diligently pursue the Work as identified in the Contract Documents. In no case is the Contractor justified or allowed to cease Work without a written stop work order from the Port or Port's Authorized Representative.

## **SECTION E**

### Payments

#### **BID SHEET**

The contractor shall submit, at least ten (10) days prior to submission of its first application for progress payment, a schedule of values for the contracted Work. This schedule will provide a breakdown of values for the contracted Work and will be the basis for progress payments. The breakdown will demonstrate reasonable, identifiable, and measurable components of the Work. Unless objected to by the Port's Authorized Representative, this schedule shall be used as the basis for reviewing Contractor's applications for payment. If objected to by Port's Authorized Representative, Contractor shall revise the schedule of values and resubmit the same for approval of Port's Authorized Representative.

**APPLICATIONS FOR PAYMENT**

Port shall make progress payments on the Contract monthly as Work progresses. Payments shall be based upon estimates of Work completed and the Schedule of Values. The Port's Authorized Representative shall approve all payments. A progress payment shall not be considered acceptance or approval of any Work or waiver of any defects therein. Port shall pay to Contractor interest on the progress payment, not including retainage, due the Contractor. The interest shall commence thirty (30) days after the receipt of invoice from the Contractor or fifteen (15) days after the payment is approved by the Port's Authorized Representative, whichever is the earlier date. The rate of interest shall equal three times the discount rate on 90-day commercial paper in effect at the Federal Reserve Bank in the Federal Reserve district that includes Oregon on the date that is thirty (30) days after receipt of the application for payment from the Contract or fifteen (15) days after the payment is approved by the Port, whichever is the earlier date, but the rate of interest shall not exceed thirty percent (30%). Notwithstanding the foregoing, in instances when an application for payment is filled out incorrectly, or when there is any defect or impropriety in any submitted application or when there is a good faith dispute, Port shall so notify the Contractor within fifteen (15) days stating the reason or reasons the application for payment is defective or improper or the reasons for the dispute. A defective or improper application for payment, if corrected by the Contractor within seven (7) days of being notified by the Port, shall not cause a payment to be made later than specified in this section unless interest is also paid. Accrual of interest will be postponed when payment on the principal is delayed because of disagreement between the Port and the Contractor.

Contractor shall submit to the Port's Authorized Representative, an application for each payment and, if required, receipts or other vouchers showing payments for materials and labor, including payments to Subcontractors. Contractor shall include, in its application for payment, a schedule of the percentages of the various parts of the Work completed, based on the Schedule of Values which shall aggregate to the payment application total, and shall include, on the face of each copy thereof, a certificate in substantially the following form:

"I, the undersigned, hereby certify that the above bill is true and correct, and the payment therefore, has not been received."

Signed:

\_\_\_\_\_

Generally, applications for payment will be accepted only for materials that have been installed. Under special conditions, applications for payment for stored materials will be accepted at Port's sole discretion. Such a payment, if made, will be subject to the following conditions:

- (a) The request for stored material shall be submitted at least thirty (30) days in advance of the application for payment on which it appears. Applications for payment shall be entertained for major equipment, components or expenditures only.
- (b) The Contractor shall submit applications for payment showing the quantity and cost of the material stored.
- (c) The material shall be stored in a bonded warehouse and Port's Authorized Representative shall be granted the right to access the material for the purpose of removal or inspection at any time during the Contract Period.
- (d) The Contractor shall name the Port as co-insured on the insurance policy covering the full value of the property while in the care and custody of the Contractor until it is installed. A certificate noting this coverage shall be issued to the Port.
- (e) Payments shall be made for materials only. The submitted amount of the application for payment shall be reduced by the cost of transportation and for the cost of an inspector to check the delivery at out of town storage sites. The cost of said inspection shall be borne solely by the Contractor.
- (f) Within sixty (60) days of the application for payment, the Contractor shall submit evidence of payment covering the material stored.
- (g) Payment for stored materials shall in no way indicate acceptance of the materials or waive any rights under this Contract for the rejection of the Work or materials not in conformance with the Contract Documents.
- (h) All required documentation must be submitted with the respective application for payment.

The Port reserves the right to withhold all or part of a payment, or may nullify in whole or part any payment previously made, to such extent as may be necessary in the Port's opinion to protect the Port from loss because of:

- (a) Work that is defective and not remedied, or that has been demonstrated or identified as failing to conform with the Contract Documents,
- (b) Third party claims filed or evidence reasonably indicating that such claims will likely be filed unless security acceptable to the Port is provided by the Contractor;
- (c) Failure of the Contractor to make payments properly to Subcontractors or for labor, materials or equipment (in which case Port may issue checks made payable jointly to Port and such unpaid persons under this provision, or directly to Subcontractors and suppliers at any level under previous sections.
- (d) Reasonable evidence that the Work cannot be completed for the unpaid balance of the Contract Price;
- (e) Damage to the Port or another contractor;
- (f) Reasonable evidence that the Work will not be completed within the Contract Time required by the Contract, and that the unpaid balance would not be adequate to cover actual or liquidated damages for the anticipated delay;
- (g) Failure to carry out the Work in accordance with the Contract Documents; or
- (h) Assessment of liquidated damages, when withholding is made for offset purposes.

Subject to the provisions of the Contract Documents, the amount of each progress payment shall be computed as follows:

- (a) Take that portion of the Contract Price properly allocable to completed Work as determined by multiplying the percentage completion of each portion of the Work by the share of the total Contract Price allocated to that portion of the Work in the Schedule of Values, less retainage as provided in section, *Retainage*. Pending final determination of cost to the Port of changes in the Work, amounts not in the dispute may be included even though the Contract Price has not yet been adjusted by Change Order.
- (b) Add that portion of the Contract Price properly allocable to materials and equipment delivered and suitably stored at the at the site for subsequent incorporation in the completed construction (or, if approved in advance by the Port pursuant to previous section, suitably stored off the site at a location agreed upon in writing), less retainage as provided in Section, *Retainage*.
- (c) Subtract the aggregate of previous payments made by the Port; and
- (d) Subtract any amounts for which the Port's Authorized Representative has withheld or nullified payment as provided in the Contract Documents.

Contractor's applications for payment may not include requests for payment for portions of the Work for which the Contractor does not intend to pay to a Subcontractor or material supplier.

The Contractor warrants to Port that title to all Work covered by an application for payment will pass to the Port no later than the time of payment. The Contractor further warrants that upon submittal of an application for payment all Work for which payments are received from the Port shall be free and clear of liens, claims, security interests or encumbrances in favor of the Contractor, Subcontractors, material suppliers, or other persons or entities making a claim by reason of having provided labor, materials and equipment relating to the Work.

If Contractor disputes any determination by Port's Authorized Representative with regard to any application for payment, Contractor nevertheless shall continue to prosecute expeditiously the Work. No payment made hereunder shall be or be construed to be final acceptance or approval of that portion of the Work to which such partial payment relates or shall relieve Contractor of any of its obligations hereunder.

#### **PAYROLL CERTIFICATION REQUIREMENT**

Payroll certification is required before payments are made on the Contract. Refer back to section, *Payroll Certification: Additional Retainage; Fee Requirements* for this information.

## **DUAL PAYMENT SOURCES**

Contractor shall not be compensated for Work performed under this Contract from any state agency other than the agency that is a party to this Contract.

## **RETAINAGE**

Retainage shall be withheld and released in accordance with ORS 279C.550 to 279C.580:

Port may reserve as retainage from any progress payment an amount not to exceed five percent (5%) of the payment. As Work progresses, Port may reduce the amount of the retainage and may eliminate retainage on any remaining monthly Contract payments after fifty percent (50%) of the Work under the Contract is completed if, in the Port's opinion, such Work is progressing satisfactorily. Elimination or reduction of retainage shall be allowed only upon written application by the Contractor, which application shall include written approval of Contractor's surety; except that when the Work is ninety-seven and one half percent (97.5%) completed the Port may, at its discretion and without application by the Contractor, reduce the retained amount to one hundred percent (100%) of the value of the Work remaining to be done. Upon receipt of written application by the Contractor, Port shall respond in writing within a reasonable time.

In accordance with the provisions of ORS 279C.560 and any applicable administrative rules, Contractor may request in writing:

- (a) to be paid amounts which would otherwise have been retained from progress payments where Contractor has deposited acceptable bonds and securities of equal value with Port or in a custodial account or other mutually-agreed account satisfactory to Port, with an approved bank or trust company to be held in lieu of the cash retainage for the benefit of Port;
- (b) *that retainage be deposited in an interest bearing account, established through the State Treasurer for state agencies, in a bank, savings banks, trust company or savings association for the benefit of Port, with earnings from such account accruing to the Contractor; or*
- (c) that the Port allow Contractor to deposit a surety bond for the benefit of Port, in a form acceptable to Port, in lieu of all or a portion of funds retained or to be retained. Such bonds and any proceeds therefrom shall be made priority as set forth for retainage under ORS 279C.550 to ORS 279C.625.

Where the Port has accepted the Contractor's election of option (a) or (b), Port may recover from Contractor any additional costs incurred through such election by reducing Contractor's final payment. Where the Port has agreed to Contractor's request for option (c), Contractor shall accept like bonds from Subcontractors and suppliers on the project from which Contractor has required retainages.

The retainage held by Port shall be included in and paid to the Contractor as part of the final payment of the Contract Price. The Port shall pay to Contractor interest at the rate of one and one-half percent (1.5%) per month on the final payment due Contractor, interest to commence thirty (30) days after the Work under the Contract has been completed and accepted and to run until the date Contractor shall notify Port in writing when the Contractor considers the Work complete and Port shall, within fifteen (15) days after receiving the written notice, either accept the Work or notify the contractor of Work yet to be performed on the contract. If Port does not within the time allowed notify the Contractor of Work yet to be performed to fulfill contractual obligations, the interest provided by the subsection shall commence to run thirty (30) days after the end of the fifteen (15) day period.

In accordance with the provisions of ORS 279C.560, Port shall reduce the amount of the retainage if the Contractor notifies the controller of the Port that the Contractor has deposited in an escrow account with a bank or trust company, in a manner authorized by the Port's Authorized Representative, bonds and securities of equal value of a kind approved by the Port's Authorized Representative.

Contractor agrees that if Contractor elects to reserve a retainage from any progress payment due to any Subcontractor or supplier, such retainage shall not exceed five percent (5%) of the payment, and such retainage withheld from Subcontractors and suppliers shall be subject to the same terms and conditions stated in Subsection, *Retainage* as apply to Port's retainage from any progress payment due to Contractor.

As provided in subsections under section *Payroll Certification: Additional Retainage; Fee Requirements*, additional retainage in the amount of twenty-five percent (25%) of amounts earned shall be withheld and

released in accordance with ORS 279C.845(7) when the Contractor fails to file certified statements as required by the first subsection of section, *Payroll Certification: Additional Retainage; Fee Requirements*.

### **FINAL PAYMENT**

Upon completion of all the Work under this Contract, the Contractor shall notify the Port's Authorized Representative, in writing, that Contractor has completed Contractor's part of the Contract and shall request final payment. Upon receipt of such notice the Port's Authorized Representative will inspect the Work, and if acceptable, submit to the Port a recommendation as to acceptance of the completed Work and as to the final estimate of the amount due the Contractor. If the Work is not acceptable, Port will notify Contractor within fifteen (15) days of Contractor's request for final payment. Upon approval of this final estimate by the Port and approval of this final estimate by the Port and compliance by the Contractor with provisions found in the Section titled, *Contract Close Out. 3 Affidavit/Release of liens and claims*, and other provisions as may be applicable; the Port shall pay to the Contractor all monies due under the provisions of these Contract Documents.

*Neither final payment nor any remaining retained percentage shall become due until the Contractor submits to the Port's Authorized Representative (1) a notarized affidavit/release of liens and claims in a form satisfactory to Port that states that payrolls, bills for materials and equipment, and other indebtedness connected with the Work for which the Port or the Port's property might be responsible or encumbered (less amounts withheld by Port) have been paid or otherwise satisfied, (2) a certificate evidencing that insurance required by the Contract Documents to remain in force after final payment is currently in effect and will not be cancelled or allowed to expire until at least thirty (30) Days' prior written notice has been given to the Port, (3) a written statement that the Contractor knows of no substantial reason that the insurance will not be renewable to cover the period required by the Contract Documents, (4) consent of surety, if any, to final payment and (5), if required by the Port, other data establishing payment or satisfaction of obligations, such as receipts, releases and waivers of liens, claims, security interests or encumbrances arising out of the Contract, to the extent and in such form as may be designated by the Port. If a Subcontractor refuses to furnish a release or waiver required by the Port, the Contractor may furnish a bond satisfactory to the Port to indemnify the Port against such lien. If such lien remains unsatisfied after payments are made, the Contractor shall refund to the Port all money that the Port may be compelled to pay in discharging such lien, including all costs and reasonable attorneys' fees.*

Acceptance of final payment by the Contractor, a Subcontractor or material supplier shall constitute a waiver of claims by that payee except those previously made in writing and identified by that payee as unsettled at the time of final application for payment.

## **SECTION F**

### **Job Site Conditions**

### **USE OF PREMISES**

Contractor shall confine equipment, storage of materials and operation of Work to the limits indicated by Contract Documents, law, ordinances, permits or directions of the Port's Authorized Representative. Contractor shall follow the Port's Authorized Representative's instructions regarding use of premises, if any.

### **PROTECTION OF WORKERS, PROPERTY, AND THE PUBLIC**

Contractor shall maintain continuous and adequate protection of all of the Work from damage, and shall protect the Port's Authorized Representative, Port's workers and property from injury or loss arising in connection with this Contract. Contractor shall remedy acceptably to the Port, any damage, injury, or loss, except such as may be directly due to errors in the Contract Documents or caused by authorized representatives or personnel of the Port. Contractor shall adequately protect adjacent property as provided by law and the Contract Documents.

Contractor shall take all necessary precautions for the safety of all personnel on the job site, and shall comply with the Contract Documents and all applicable provisions of federal, state and municipal safety laws and building codes to prevent accidents or injury to persons on, about or adjacent to the premises where the Work is being performed. Contractor shall erect and properly maintain at all times, as required by the conditions and progress of workers and the public against any hazards created by construction. Contractor shall designate a responsible employee or associate on the Work site, whose duty shall be the prevention of

accidents. The name and position of the person designated shall be reported to the Port's Authorized Representative. The Port's Authorized Representative has no responsibility for Work site safety. Work site safety is the responsibility of the Contractor.

Contractor shall not enter upon private property without first obtaining permission from the property Port or its duly Authorized Representative. Contractor shall be responsible for the preservation of all public and private property along and adjacent to the Work contemplated under the Contract and shall use every precaution necessary to prevent damage thereto. In the event the Contractor damages any property, the Contractor shall at once notify the property owner and Port and make, or arrange to make, full restitution. Contractor shall report, immediately in writing, to the Port's Authorized Representative, all pertinent facts relating to such property damage and the ultimate disposition of the claim for damage.

Contractor is responsible for protection of adjacent work areas including impacts brought about by activities, equipment, labor, utilities, and materials on the site.

Contractor shall at all times direct its activities in such a manner as to minimize adverse effects on the environment. Handling of all materials will be conducted so no release will occur that may pollute or become hazardous.

In an emergency affecting the safety of life or of the Work or of adjoining property, the Contractor, without special instruction or authorization from the Port's Authorized Representative, shall act reasonably to prevent threatened loss or injury, and shall so act, without appear, if instructed by the Port's Authorized Representative. Any compensation claimed by the Contractor on account of emergency work shall be determined in accordance with the Section titled *Changes in the Work*.

Contractor shall, at its sole expense, provide all traffic control signage, barriers, and flaggers at no additional cost to Owner.

#### **CUTTING AND PATCHING**

Contractor shall be responsible for coordinating all cutting, fitting, or patching of the Work to make its several parts come together properly and fit to receive or be received by work of other Contractors or Subcontractors shown upon, or reasonably implied by, the Contract Documents.

Contractor shall be responsible for restoring all cut, fitted, or patched surfaces to an original condition; provided, however, that if a different condition is specified in the Contract Documents, then Contractor shall be responsible for restoring such surfaces to the condition specified in the Contract Documents.

#### **CLEANING UP**

From time to time as may be ordered by the Port the Contractor shall, at its own expense, clean up and remove all refuse and unused materials of any kind resulting from the Work. If Contractor fails to do so within twenty-four (24) hours after notification by the Port, the work may be done by others and the cost charged to the Contractor and deducted from payment due to the Contractor.

#### **DISPOSAL OF SURPLUS MATERIALS**

No waste site has been provided by Owner for the disposal of excess materials and debris. Debris shall be taken by Contractor to a disposal site approved by Owner. Contractor shall keep site clean, safe and free of debris. Contractor shall dispose of waste materials in an Owner-approved location.

#### **ENVIRONMENTAL CONTAMINATION**

Contractor will be held responsible for and shall indemnify, defend (with counsel of Port's choice) and hold harmless Port from and against any costs, expenses, damages, claims, and causes action, (including attorney fees), or any of them, resulting from all spills, releases, discharges, leaks and disposal of environmental pollution, including storage, transportation and handling during the performance of the Contract which occur as a result of, or are contributed by, the negligence or actions of Contractor or its personnel, agents, or Subcontractors or any failure to perform in accordance with the Contract Documents (except to the extent otherwise void under ORS 30.140). Nothing in this section shall limit Contractor's responsibility for obtaining insurance coverage required under section titled *Insurance* of these General Conditions, and Contractor shall take no action that would void or impair such coverages.

Contractor agrees to promptly dispose of such spills, releases, discharge or leaks to the satisfaction of proper regulatory agencies in a manner that complies with applicable federal, state, and local laws and regulations. Cleanup shall be at no cost to the Port and be performed by properly qualified personnel.

Contractor shall obtain the Port's written consent prior to bringing onto the Work site any (i) environmental pollutants or (ii) hazardous substances or materials, as the same or reasonably similar terms are used in many applicable federal, state, or local statutes, rules and ordinances. Notwithstanding such written consent from the Port, the Contractor, at all times, shall:

- (a) properly handle, use and dispose of all environmental pollutants and hazardous substances or materials brought onto the Work site, in accordance with all applicable federal, state or local statutes, rules or ordinances;
  - i. Contractor must have in date spill response kit on the dock or work vessel and assessable at all times.
- (b) be responsible for any and all spills, releases, discharges, or leaks of (or from) environmental pollutants or hazardous substances or materials which Contractor has brought onto the Work site; and
- (c) promptly clean up, without cost to the Port, such spills, releases, discharges, or leaks to the Port's satisfaction and in compliance with all applicable federal, state, or local statutes, rules or ordinances.

Contractor shall report all reportable quantity releases to applicable federal, state, and local regulatory and emergency response agencies. Reportable quantities are found in 40 CFR Part 302, Table 302.4 for hazardous substances and in OAR Chapter 340 Division 108 for all products addressed therein. Upon discovery, regardless of quantity, Contractor must telephonically report all releases to the Port. A written follow-up report shall be submitted to the Port within forty-eight (48) hours of the telephonic report. Such written report shall contain, as a minimum:

- (a) Description of items released (identity, quantity, manifest no., and all other documentation required by law.
- (b) Whether amount of items released is EPA/DEQ reportable, and, if so, when it was reported.
- (c) Exact time and location of release, including a description of the area involved.
- (d) Containment procedures initiated.
- (e) Summary of communications about the release Contractor has had with members of the press or State officials other than Port.
- (f) Description of cleanup procedures employed or to be employed at the site, including disposal location of spill residue.
- (g) Personnel injuries, if any, resulting from, or aggravated by, the release.

#### **ENVIRONMENTAL CLEAN-UP**

Unless disposition of environmental pollution is specifically a part of this Contract, or was caused by the Contractor (reference section titled *Environmental Contamination*), Contractor shall immediately notify Port of any hazardous substance(s) which Contractor discovers or encounters during performance of the Work required by this Contract. "Hazardous Substance(s)" means any hazardous, toxic and radioactive materials and those substances defined as "hazardous substances," "hazardous materials," "hazardous wastes," "toxic substances," or other similar designations in any federal, state, or local law, regulation, or ordinance, including without limitation asbestos, polychlorinated biphenyl (PCB), or petroleum, and any substances, materials or wastes regulated in 40 CFR, Part 261 and defined as hazardous in 40 CFR S 261.3. In addition to notifying Port of any hazardous substance(s) discovered or encountered, Contractor shall immediately cease working in any particular area of the project where a hazardous substance(s) has been discovered or encountered if continued to work in such area would present a risk or danger to the health or well being of Contractor's or any Subcontractor's work force.

Upon being notified by Contractor of the presence of hazardous substance(s) on the project site, Port shall arrange for the proper disposition of such hazardous substance(s).

**FORCE MAJEURE**

A party to this Contract shall not be held responsible for delay or default due to Force Majeure acts, events or occurrences unless they could have been avoided by the exercise of reasonable care, prudence, foresight, and diligence by that party. The Port may terminate this Contract upon written notice after determining that delay or default caused by Force Majeure acts, events or occurrences will reasonably prevent successful performance of the Contract.

**SECTION G**

Indemnity, Bonding, and Insurance

**RESPONSIBILITY FOR DAMAGES/INDEMNITY**

Contractor shall be responsible for all damages to property, injury to persons, and loss, expense, inconvenience, and delay that may be caused by, or result from the carrying out of Work to be done under this Contract, or from any act, omission or neglect of the Contractor, its Subcontractors, personnel, or agents.

To the fullest extent permitted by law, Contractor shall indemnify and hold harmless the PORT, Port's Authorized Agent, its properties, officers, employees, and Architect/Engineer Consultants from and against all liabilities, damages, losses, claims, expenses (including reasonable attorney fees), demands and actions of any nature whatsoever which arise out of, result from or are related to (a) any damage, injury, loss, expense, inconvenience or delay described here, (b) any accident or occurrence which happens or is alleged to have happened in or about the project site or any place where the Work is being performed, or in the vicinity of either at any time prior to the time the Work is fully completed, (c) any failure of the Contractor to observe or perform any duty or obligation under the Contract Documents which is to be observed or performed by the Contractor, or any breach of agreement, representation or warranty of the Contractor contained in the Contract Document or any subcontract, (d) the negligent acts or omissions of the Contractor, a subcontractor or anyone directly or indirectly employed by them or any one of them or anyone for whose acts they may be liable, regardless of whether or not such claim, damage, loss or expense is caused in part by a party indemnified hereunder (except to the extent otherwise void under ORS 30.140) and (e) any lien filed upon the project or bond claim in connection with the Work. Such obligation shall not be construed to negate, abridge, or reduce other rights or obligations of indemnity which would otherwise exist as to a party or persons described in this section.

**PERFORMANCE AND PAYMENT SECURITY; PUBLIC WORKS BOND**

When the contract price is \$100,000 or more (\$50,000 or more in the case of Contracts for highways, bridges and other transportation projects) the Contractor shall furnish and maintain in effect at all times during the Contract Period, a performance bond in a sum equal to the Contract Price, and a separate payment bond also in a sum equal to the Contract Price. The bonds may be required if the Contract Price is less than the above thresholds, if required by the Contract Documents.

Before starting Work, the Contractor shall file with the Construction Contractors Board, and maintain in full force and effect, the separate public works bond required by Oregon laws 2005, chapter 360, and OAR 839-025-0015, unless otherwise exempt from those provisions. The Contractor shall also include in every subcontract a provision requiring the Subcontractor to have a public works bond filed with the Contractors Construction Board before starting Work, unless otherwise exempt, and shall verify that the Subcontractor has filed a public works bond before permitting the Subcontractor to start Work.



## **INSURANCE**

**Worker's Compensation:** All employers, including Contractor, that employ subject workers who work under this contract in the State of Oregon shall comply with ORS 656.017 and provide the required Workers Compensation coverage, unless such employers are exempt under ORS 656.126. This shall include Employer's Liability Insurance with coverage limits of not less than \$100,000 for each accident. Contractors who perform the Work without the assistance or labor of any employee need not obtain such coverage if the Contractor certifies so in writing. Contractor shall ensure that each of its subcontractors complies with these requirements. The Contractor shall require proof of such Workers' Compensation by receiving and keeping on file a certificate of insurance from each Subcontractor or anyone else directly employed by either the Contractor or Subcontractors.

**Builder's Risk:** During the term of this Contract, for new construction the Contractor shall maintain in force, at its own expense, Builder's Risk Insurance on an all risk form, including earthquake and flood, for an amount equal to the full amount of the Contract. Such insurance shall be maintained until the Owner has occupied the facility.

**Commercial General Liability Insurance:** Contractor shall obtain, at Contractor's expense, and keep in effect during the term of this Contract, Commercial General Liability Insurance covering bodily injury and property damage in a form and with coverages that are satisfactory to the Port. This insurance shall include personal injury liability, products and completed operations, and contractual liability coverage for the indemnity provided under this Contract (to the extent contractual liability coverage for the indemnity is available in the marketplace), and shall be issued on an occurrence basis. Combined single limit per occurrence shall not be less than \$1,000,000 for each job site or location. Each aggregate limit shall not be less than \$1,000,000.

**Automobile Liability:** Contractor shall obtain, at Contractor's expense, and keep in effect during the term of this Contract, Automobile Liability Insurance owned, non-owned and/or hired vehicles, as applicable. The coverage may be written in combination with the Commercial General Liability Insurance. Combined single limit per occurrence shall not be less than \$1,000,000, or the equivalent.

**Tail Coverage:** If any of the required liability insurance is on a "claims made" basis, "tail" coverage will be required at the completion of the Contract for a duration of 24 months. Contractor will be responsible for furnishing certification of "tail" coverage as described or continuous "claims made" liability for twenty-four (24) months following Final Completion. Continuous "claims made" coverage will be acceptable in lieu of "tail" coverage, provided its retroactive date is on or before the effective date of this Contract. This will be a condition of final acceptance.

**Additional Insured:** The liability Insurance coverage, except for the Professional Liability if included, required for this Contract shall include the Port, officers, and employees, as Additional Insureds but only with respect to the Contractor's activities to be performed under this Contract.

There shall be no cancellation, material change, potential exhaustion coverages without thirty (30) Days' written notice from the Contractor or its insurer(s) to the Port.

As evidence of coverage, Contractor shall furnish the a certificate of insurance to Port prior to Issuance of a Notice to Proceed. The certificate will specify all of the parties who are Additional Insureds or Loss Payees. Insurance coverages required under this Contract shall be obtained from insurance companies or entities acceptable to the Port that are allowed to provide such insurance under Oregon law. The certificate will also specify that there shall be no cancellation, material change, potential exhaustion of aggregate limits or intent to not renew insurance coverages without thirty (30) Days' written notice from the insurer(s) to Port. The Contractor shall be financially responsible for all deductibles, self-insured retentions and/or self-insurance included hereunder. Any deductible, self-insured retention and/or self insurance in excess of \$50,000 shall be approved by the Port in writing prior to issuance of a Notice to Proceed and is subject to Port's approval.

Insurance coverages required under this Contract shall be obtained from insurance companies or entities acceptable to the Port that are allowed to provide such insurance under Oregon law.

**Jones Act: The contractor must be aware of the requirements of this act and have the necessary maritime insurance in place.**

## **SECTION H**

### Schedule of Work

#### **CONTRACT PERIOD**

Time is of the essence on this contract. The Contractor shall at all times carry on the Work diligently, without delay and punctually fulfill all requirements herein. Contractor shall commence work within ten (10) days of Notice to Proceed, unless otherwise directed.

Unless specifically extended by Change Order, all Work shall be complete by the date contained in the Contract Documents.

The Port will not waive any rights under the Contract by permitting the Contractor to continue or complete the Work or any part of it after the date described above.

#### **SCHEDULE**

Contractor shall provide, by or before the pre-construction conference, a detailed schedule for review and acceptance by the Port. The submitted schedule must illustrate Work by significant project components, significant labor trades and long lead times. Schedules lacking adequate detail, or unreasonably detailed, will be rejected. Included within the schedule are the following: Notice to Proceed, Substantial Completion, and Final Completion. Schedules will be updated monthly and submitted with the monthly pay application. Acceptance of the schedule by the Port does not constitute agreement by the Port, as to the Contractor's sequencing, means, methods or allocated Contract Time. In no case shall the Contractor make a request for additional compensation for delays if the Work is completed within the Contract Time but after the Contractor's scheduled completion.

#### **WORKING DAYS**

Contractor shall complete all physical Contract Work within the number of "working days" stated in the Contract Provisions or as extended by Owner. Every day will be counted as a "working day" unless it is a nonworking day or an Owner-determined unworkable day. A nonworking day is defined as a Saturday, a Sunday, a day on which the Contract specifically suspends Work, or one of these Owner holidays: New Year's Day, Presidents' Day, Memorial Day, Independence Day, Labor Day, Veterans' Day, Thanksgiving Day, and Christmas Day.

An unworkable day is defined as a half or whole day Owner declares to be unworkable because of weather or conditions caused by the weather that prevents satisfactory and timely performance of the Work shown on the critical path of the Contractor's approved progress schedule. Other conditions beyond the control of the Contractor may qualify for an extension of time.

Each working day shall be charged to the Contract as it occurs, until the Contract Work is physically complete. If Substantial Completion has been granted and all the authorized working days have been used, charging of working days will cease. Each week the Owner will provide the Contractor a statement that shows the number of working days: (1) charged to the Contract the week before; (2) specified for the Physical Completion of the Contract; and (3) remaining for the Physical Completion of the Contract. The statement will also show the nonworking days and any half or whole day the Owner declares as unworkable. Within 10-calendar days after the date of each statement, the Contractor shall file a written protest of any alleged discrepancies in it. To be considered by the Owner, the protest shall be in sufficient detail to enable the Owner to ascertain the basis and amount of time disputed. By not filing such detailed protest in that period, the Contractor shall be deemed as having accepted the statement as correct.

Owner will give the Contractor written notice of the Physical Completion Date for all Work the Contract requires. That date shall constitute the Physical Completion Date of the Contract, but shall not imply Owner acceptance of the Work or the Contract.

Owner will give Contractor written notice of the Completion Date of the Contract after all the Contractor's obligations under the Contract have been performed by the Contractor. The following events must occur before the Completion Date can be established:

1. The physical Work on the project must be complete; and
2. The Contractor must furnish all documentation required by the Contract and required by law, to allow Owner to process final acceptance of the Contract. The following documents must be received by Owner prior to establishing a Completion Date:
  - a. Certified Payrolls
  - b. Material Acceptance Certification Documents
  - c. Final Contract Voucher Certification

## **SECTION I**

### Correction of Work

#### **BEFORE FINAL PAYMENT**

The Contractor warrants to the Port that materials and equipment furnished under this Contract will be of good quality and new unless otherwise required or permitted by the Contract Documents, that the work will be free from defects, and that the Work will conform to the requirements of the Contract Documents. Work failing to conform to these requirements shall be deemed defective. Contractor shall promptly remove from the premises and replace all defective materials and equipment as determined by the Port's Authorized Representative, whether incorporated in the Work or not. Removal and replacement shall be without loss or expense to the Port, and Contractor shall bear the cost of repairing all Work destroyed or damaged by such removal or replacement. Contractor shall be allowed a period of no longer than sixty (60) days for completion of defective (punch list) work, unless otherwise agreed. At the end of that period, or earlier if requested by the Contractor, the Port shall arrange for inspection of the Work by the Architect/Engineer. Should the work not be complete, and all corrections made, the costs for all subsequent re-inspections shall be borne by the Contractor. If Contractor fails to complete the punch list work within the above time period, without affecting Contractor's obligations the Port may perform such work and Contractor shall reimburse the Port all costs of the same within thirty (30) days after demand.

#### **WARRANTY WORK**

Neither the final certificate of payment nor any provision of the Contract Documents shall relieve the Contractor from responsibility for defective work and, unless a longer period is specified, Contractor shall correct all defaults that appear in the work within a period of one year from the date of issuance of the written notice of substantial completion by the Port except for latent defects which will be remedied by the Contractor at any time they become apparent.

The Port shall give the Contractor notice of defects with reasonable promptness. Contractor shall perform such warranty work within a reasonable time after Port's demand. If Contractor fails to complete the warranty work within such period as Port determines reasonable, or at any time in the event of warranty work consisting of emergency repairs, without affecting Contractors obligations, Port may perform such work and Contractor shall reimburse Port all costs of the same within thirty (30) days after demand.

This provision does not negate guarantees or warranties for periods longer than one year including without limitations such guarantees or warranties required by other sections of the Contract Documents for specific installations, materials, processes, equipment or fixtures.

In addition to Contractor's warranty, manufacturer's warranties shall pass to the Port and shall not take effect until affected work has been accepted in writing by the Port's Authorized Representative.

The one-year (1) period for correction of Work shall be extended with respect to portions of Work performed after substantial completion by the period of time between substantial completion and the performance of the work, and shall be extended by corrective Work performed by the Contractor pursuant to this section, as to work corrected.

If the Port prefers to accept Work which is not in accordance with the requirements of the Contract Documents, the Port may do so instead of requiring its removal and correction, in which case the Contract

Price will be reduced as appropriate and equitable. Such adjustment shall be effected whether or not final payment has been made.

## **Section J**

### Suspension or Termination of the Work

#### **PORT'S RIGHT TO SUSPEND WORK**

The Port and the Port's Authorized Representative has the authority to suspend portions or all of the Work due to the following causes:

- (a) Failure of the Contractor to correct unsafe conditions;
- (b) Failure of the Contractor to carry out any provision of the Contract;
- (c) Failure of the Contractor to carry out orders;
- (d) Conditions, in the opinion of the Port's Authorized Representative, which are unsuitable for performing the work;
- (e) Time required to investigate differing site conditions;
- (f) Any reason considered to be in the public interest.

The Port shall notify the Contractor and the Contractor's Surety in writing of the effective date and time of the suspension and shall notify Contractor and its Surety in writing to resume work.

#### **CONTRACTOR'S RESPONSIBILITIES**

During the period of suspension, Contractor is responsible to continue maintenance at the project just as if the work were in progress.

#### **COMPENSATION FOR SUSPENSION**

Depending on the reason for suspension of the Work, the Contractor or the Port may be due compensation from the other party. If the suspension was required due to acts or omissions of the Contractor, the Port may assess the Contractor actual costs of the suspension. If the suspension was caused by acts or omissions of the Port, the Contractor shall be due compensation which shall be defined under "Changes in Work". If the suspension was required through no fault of the Contractor or the Port, neither party owes the other for the impact.

#### **PORT'S RIGHT TO TERMINATE CONTRACT**

The Port without prejudice to any other right or remedy, and after giving Contractor seven (7) Days written notice and an opportunity to cure, terminate the Contract in whole or part under the following conditions:

- (a) If Contractor should voluntarily or involuntarily, seek protection under the US Bankruptcy Code and Contractor as debtor-in-possession or the Trustee for the estate fails to assume the Contract within a reasonable time;
- (b) If Contractor should make a general assignment for the benefit of Contractor's creditors;
- (c) If a receiver should be appointed on account of Contractor's insolvency;
- (d) If Contractor should repeatedly refuse or fail to supply an adequate number of skilled workers or proper materials to carry on the Work as required by the Contract Documents, or otherwise fail to perform the Work in a timely manner;
- (e) If Contractor should repeatedly fail to make prompt payment to Subcontractors or for material or labor, or should disregard laws, ordinances or the instructions of the Port or Authorized Representative;
- (f) If Contractor is otherwise in material breach of any part of the Contract.

At any time the above occurs, the Port may exercise all rights and remedies available to Port at law or equity, and in addition, Port may take possession of the premises and all of the materials and appliances and finish the Work by whatever method it may deem expedient. In such case, the Contractor shall not be entitled to receive further payment until the work is completed. If the Port's cost of finishing the Work exceeds the unpaid balance of the Contract Price, Contractor shall pay the difference to the Port.

#### **TERMINATION FOR CONVENIENCE**

Port may terminate the Contract in whole or in part whenever Port determines that termination of the Contract is in the best interest of the public.

The Port will provide the Contractor with seven (7) Days' prior written notice of a termination for public convenience. After such notice, the Contractor shall provide the Port with immediate and peaceful possession of the premises and materials located on and off premises for which the Contractor received progress payment. Compensation for Work terminated by the Port under this provision will be paid according to the terms of "Payment of Work." In no circumstances shall Contractor be entitled to lost profits for Work not performed due to termination.

#### **ACTION UPON TERMINATION**

Upon receiving a notice of termination, and except as otherwise directed by the Port, Contractor shall immediately cease placing further subcontracts or orders for materials, services, or facilities. In addition, Contractor shall terminate all subcontracts or orders to the extent they relate to the Work terminated and, with the prior written approval of the Port, settle all outstanding liabilities and termination settlement proposals arising from the termination of subcontracts and orders.

As directed by the Port, Contractor shall upon termination transfer title and deliver to the Port all record documents, information, and other property that, if Contract had been completed, would have been required to be furnished to the Port.

### **SECTION K**

#### **Contract Close Out**

#### **RECORD DOCUMENTS**

As a condition of final payment, Contractor shall comply with the following: Contractor shall provide to the Port's Authorized Representative, Record Documents ("Record Drawings;" "As Built") of the entire project. Record Documents shall depict the project as constructed and shall reflect every change, modification, and deletion made during the construction. Record Documents are part of the Work and shall be provided prior to the issuance of final payment. Record Documents include all modifications to the Contract Documents unless otherwise directed. Record Documents shall be provided in an electronic format along with paper copies in 24"x36" dimension.

#### **OPERATION AND MAINTENANCE MANUALS**

The O & M Manuals shall contain a complete set of all submittals, all product data as required by the specifications, training information, phone list of consultants, manufactures, installer and suppliers, manufacturer's printed data, record and shop drawings, schematic diagrams of systems, appropriate equipment indices, warranties and bonds. The Port's Authorized Representative shall review and return one O & M Manual for any modifications or additions required. Prior to submission of its final pay request, Contractor shall deliver three (3) complete and approved sets of O & M Manuals to the Port's Authorized Representative.

#### **AFFIDAVIT/RELEASE OF LIENS AND CLAIMS**

As a condition of final payment, the Contractor shall submit to the Port's Authorized Representative a notarized affidavit/release of liens and claims form, in a form satisfactory to the Port, which states that all subcontractors and suppliers have been paid in full, all disputes with property owners and the Port have been resolved, all obligations on the project have been satisfied, all monetary claims and indebtedness have been paid, and that to the best of the Contractor's knowledge, there are no claims of any kind outstanding against the project. The Contractor shall indemnify, defend (with counsel of Port's choice) and hold

harmless the Port from all claims for labor and materials furnished under this Contract.

**COMPLETION NOTICES**

Contractor shall provide the Port notice of both Substantial and Final Completion. The certificate of Substantial Completion shall state the date of Substantial Completion, the responsibilities of the Port and the Contractor for security, maintenance, heat, utilities, damage to Work and insurance, and the time within which the Contractor shall finish all items on the punch list accompanying the Certificate. Both completion notices must be signed by the Contractor and the Port to be valid. The Port shall provide the final signature on the notices. The notices shall take effect on the date signed by the Port.

**TRAINING**

As part of the Work, and prior to submission of the request for final payment, the Contractor shall schedule with the Port's Authorized Representative, training sessions for all equipment and systems, as required in the individual specifications sections. The O & M Manuals shall be used as a basis for training.

**EXTRA MATERIALS**

As part of the Work, Contractor shall provide spare parts, extra maintenance materials, and other materials or products in the quantities specified in the specifications, prior to final payment.

**ENVIRONMENTAL CLEANUP**

As part of the Final Completion notice, or as a separate written notice submitted with or before the Final Completion, the Contractor shall notify the Port that all environmental pollution clean-up which was performed as part of this Contract has been disposed of in accordance with all applicable rules, regulations, laws, and statues of all agencies having jurisdiction over such environmental pollution. The notice shall reaffirm the indemnification given under Section E.

**CERTIFICATE OF OCCUPANCY**

The Contractor shall not be granted Final Completion or receive final payment if the Port has not received an unconditioned certificate of occupancy from the appropriate state and/or local building officials, unless failure to obtain an unconditional certificate of occupancy is due to the fault or neglect of the Port.

**OTHER CONTRACTOR RESPONSIBILITIES**

The Contractor shall be responsible for returning to the Port all items issued during construction such as keys and all other pertinent items. The Contractor shall be responsible for notifying the appropriate utility companies to transfer utility charges from Contractor to the Port.

**SURVIVAL**

All warranty and indemnification provisions of this Contract, and all of Contractor's other obligations under this contract that are not fully performed by the time of Final Completion or termination, shall survive Final Completion or any termination of the Contract.

**SECTION L**

Legal Relations & Responsibilities

**LAWS TO BE OBSERVED**

In compliance with ORS 279C.525, there are federal, state, and local agencies of which the Port has knowledge that have enacted ordinances or regulations relating to environmental pollution and the preservation of natural resources that may affect the performance of the Contract.

## **PART 9**

### **TECHNICAL SPECIFICATIONS**

#### **Applicable Specifications**

The Specifications that are applicable to the Work on this Project is the 2021 Oregon Standard Specifications for Construction. All number references in the following Special Provisions shall be understood to refer to the Sections and subsections of the Standard Specifications bearing like numbers and to Sections and subsections contained in these Special Provisions in their entirety.

#### **SPECIAL PROVISIONS**

## SECTION 00210 - MOBILIZATION

Comply with Section 00210 of the Standard Specifications.

## SECTION 00220 - ACCOMMODATIONS FOR PUBLIC TRAFFIC

Comply with Section 00220 of the Standard Specifications modified as follows:

**00220.02(a) General Requirements** - Add the following bullets to the end of the bullet list:

- Use portable changeable message signs to provide appropriate work zone information to the public. Place signs and display messages as directed or approved. Place signs in the following approximate locations, 100 feet from the intersection:
  - Button Bridge Road at Marina Drive Intersection, center of travelway.
  - Hood River Bridge approach at Washington SR 14, center of travelway and behind crosswalk.

Place two eight-foot Type III barricades across travelway behind PCMS signs.

Display pre-approved messages during construction activity requiring a PCMS use. When signs are in use, provide them according to 00222.45(b).

Suggested message panel 1  
BRIDGE  
CLOSED  
9 PM – 5 AM

Suggested message panel 2

**00220.40(e)(1) Closed Lanes** - Replace this subsection, except for the subsection number and title, with the following:

Do not close any traffic lanes and remove all barricades and objects from the roadway during the following periods:

- Weekdays: Between 6:00 a.m. and 9:00 a.m. and between 3:00 p.m. and 6:00 p.m. Monday through Friday.
- Weekends: Between 3:00 p.m. Friday and 9:00 p.m. Sunday.

A maximum of fifteen (15) single lane closures for up to 20 minutes will be allowed during the project.



Add the following subsection:

**00220.40(f) Nighttime Bridge Closure** - Nighttime bridge closures are allowed from 9:00 p.m. to 5:00 a.m. Sunday through Thursday. The Contractor shall provide the dates and anticipated number of closures as part of their schedule.

The Contractor shall provide an onsite safety contact in writing, including name and phone number, to the Port of Hood River. The safety contact shall be available by phone during all hours of the bridge closure to coordinate emergency crossings. The contact information will be distributed to 911 center, area dispatch, emergency personnel or a public emergency relayed through the Port Emergency phone. The Contractor shall open barricades for emergency crossings and shall provide safe passage through the construction zone on the bridge for emergency vehicles.

Any change to the safety contact must be provided in writing at least 72 hours prior to implementation.

The Contractor shall always be able to clear a single lane of traffic for emergency vehicles within 10 minutes of receiving an emergency call.

Add the following subsection:

**00220.45 Load Restrictions on Bridges** -

For Structure No. 06645 (Hood River Bridge), limit the combined weight of Equipment, vehicles, and supplies placed in a closed Traffic Lane or Shoulder on the Bridge according to 00253.46.

## **SECTION 00221 - COMMON PROVISIONS FOR WORK ZONE TRAFFIC CONTROL**

Comply with Section 00221 of the Standard Specifications.

## **SECTION 00253 - TEMPORARY WORK ACCESS AND CONTAINMENT**

Comply with Section 00253 of the Standard Specifications modified as follows:

**00253.00 Scope** - Add the following paragraph to the end of this subsection:

On Structure No. 06645 (Hood River Bridge), provide temporary work access and containment systems for all work over water as needed to prevent materials from entering the water.

**00253.03 Submittals** - Replace this subsection, except for the subsection number and title, with the following:

**(a) Fixed Work Access Submittals** - Submit all specified stamped drawings, specifications and design calculations for fixed work platforms, and scaffolding according to 00150.35 at least 21

Calendar Days prior to the installation of work access systems(s). When work access system submittal is segmented, include loading from previously accepted segments in the calculations.

Submit the following:

- Stamped design calculations assuring that the Bridge structural members can safely resist the combined effects of dead loads, live loads, and wind loads
- Stamped work access specifications and design calculations
- Stamped Working Drawings clearly defining on the face of the plans the following:
  - Work platform, scaffolding, and containment system dead load (in pounds and pounds per square foot)
  - Maximum allowable accumulations of collected debris or water (inches depth) allowed in conjunction with all personnel, construction vehicles, Equipment, Material, and other simultaneous loading
  - Maximum allowable personnel, construction vehicles, Equipment, Material, and other simultaneous loading
  - Maximum wind speed at which work access structure(s) may remain on the Structure
  - Dimensional limits and loading limits that satisfy the conditions listed in 00253.09 for exemption from design calculations for the Bridge structural members.

**(b) Work Containment Submittals** - Submit all specified stamped drawings, specifications and design calculations for fixed containment and access, systems according to 00150.35 at least 21 Calendar Days prior to the installation of work access systems(s).

Submit the following:

- Stamped containment Working Drawings, specifications and design calculations.
- Maximum wind speed at which containment wall materials may remain on the Structure.
- A view showing the location(s), and magnitude(s) of containment system reactions that are applied to the supporting structure.
- Appropriate submittals for access Structure(s), barge, or other information critical to the function of the containment system.

**(c) U.S. Coast Guard Bridge Work Plan** – When fixed work platforms extend below the bottom truss chord of any span, obtain Coast Guard approval of U. S. Coast Guard Bridge Work Plan in advance of performing work. Include the following in the submittal:

- Provide company/organization name and point of contact with phone number and email address.
- State type of project (i.e., bridge repair).
- Provide drawings of the project and work access platform.
- List start and end dates.
- List days of the week and times of operation.
- Location of work in latitude and longitude.
- List construction vessels and equipment in the waterway, if any, and direct contact information such as VHF frequencies, cell phone, etc. State whether they will be moored or anchored, what obstructions to the channel, and their lighting plans.

- Provide point of contact available for mariners at all times during construction.
- List construction hazards to mariners in detail, if any.
- List any special contractor requirements or requests, if any.
- List vertical clearance reductions, if any. If the work access platform extends below the existing bridge soffit, provide a dimension. If vertical clearance is impacted by structures or activity, limit the reduced clearance to no more than half the navigable channel at a time. If more than half the navigable channel is impacted, perform a navigation survey to show that all vessel traffic can transit under the bridge with the reduced clearance.
- Include details for cautionary lighting and signage for the work access platform, clearly visible to mariners.
- List dates and times of the construction stages.

Submit written request to:  
 Commander (dpw)  
 13<sup>th</sup> Coast Guard District  
 915 2<sup>nd</sup> Avenue, Room 3510  
 Seattle, WA 98174-1067  
 Attn: Bridge Administrator

Allow at least 30 days for Coast Guard review and approval,

**(d) Mobile Work Platforms** – When mobile under-bridge work platforms from the roadway surface are used for access and containment systems, stamped drawings, specifications, and design calculations are not required. Provide equipment and material loads to be used within the roadway surface according to 00150.35 at least 21 Calendar Days before beginning work. Loads to be limited according to 00253.46.

**(e) Loads Placed on Structure Roadway** - Submit all specified stamped drawings, specifications and design calculations for loads placed on Structure Roadway, Shoulders, and sidewalks according to 00150.35 at least 21 Calendar Days before construction loading is placed on the structure.

Submit the following:

- Stamped calculations for Equipment, vehicles, and supplies placed in a closed lane according to 00253.46

Add the following subsection:

**00253.09 Work Platform, Scaffolding and Containment Structural Design Requirements -**

If mobile under-bridge work platforms from the roadway surface are not used, provide the following:

Design work platforms, scaffolding, and containment Structures for dead load, live load, and wind load. Obtain basic wind speed as shown on Standard Drawing TM671 and applied in the most critical direction. For Structures with fundamental frequency less than 1 Hz, design for wind loads accounting for structural dynamic effects.

Provide designs with a factor of safety of at least six for wire ropes and connecting hardware and at least four for all other components for containment Structure and work platform components.

Verify structural adequacy of the Bridge with added loading from containment Structures and work platforms using AASHTO *Standard Specifications for Highway Bridges*, Group II, III, V, and VI load combinations.

**(a) Containment Structures Positioned Symmetrically on any Span** - For containment structures positioned symmetrically on any span, design calculations for the bridge structural members are not required if all of the following conditions are satisfied:

- Total combined live load and dead load of all work platforms and containment Structures supported by the span, including all personnel, Equipment, Materials, and collected debris or water, does not exceed the provisions of 00253.46.

**(b) Containment Structures Positioned Asymmetrically on any Span** - For containment structures positioned asymmetrically on any span, design calculations for the bridge structural members are not required if all of the following conditions are satisfied:

- Total combined live load and dead load of all work platforms and containment Structures supported by the span, including all personnel, Equipment, Materials, and collected debris or water, does not exceed the provisions of 00253.46.

**00253.40 General** - Add the following paragraph to the end of this subsection:

For movable Structures, provide positive restraint to prevent movement except when containment structures are being relocated.

Containment and work platforms do not extend more than five feet below bottom of existing Structure.

Add the following subsection:

**00253.44 Marine Traffic Restrictions** -

Bridge No. 06645 (Hood River Bridge) may not be closed to marine traffic.

Add the following subsection:

**00253.46 Loads Placed on Structure Roadway** - During nighttime bridge closures the following loading may be applied to the structure(s):

The combined loads of equipment and materials within a lane of any span shall not be greater than the force effects of legal live loads allowed on the bridge. The adjacent lane of the same span may not have more than one-half of the legal load allowed.

**00253.50 Electrical Service** - Delete this subsection.

## SECTION 00290 - ENVIRONMENTAL PROTECTION

Comply with Section 00290 of the Standard Specifications modified as follows:

Add the following subsection:

### **00290.30(a)(7) Water Quality:**

- Do not discharge contaminated or sediment-laden water, including drilling fluids and waste, or water contained within a work area isolation, directly into any waters of the State or U.S. until it has been satisfactorily treated (using a best management practice such as a filter, settlement pond, bio-bag, dirt-bag, or pumping to a vegetated upland location).
- Implement containment measures adequate to prevent pollutants or construction and demolition materials, such as waste spoils, fuel or petroleum products, concrete cure water, silt, welding slag and grindings, concrete saw cutting by-products and sandblasting abrasives, from entering waters of the State or U.S.
- The Engineer retains the authority to temporarily halt or modify the Work in case of excessive turbidity or damage to natural resources.
- If Work activities violate permit conditions or any requirement of this subsection, stop all in-water work activities and notify the Engineer.
- Do not cause a visible sediment plume in waters of the State or U.S.

### **00290.34(a) Regulated Work Areas** - Add the following to the end of this subsection:

The regulated work area is the area at or below the ordinary high water (OHW) elevation 86.70 feet NGVD.

Perform no work within the regulated work area under the bridge.

### **00290.34(b) Prohibited Operations** - Add the following to the end of this subsection:

Allow entry within the regulated work area

### **00290.36(a) Migratory Birds** - Add the following to the end of this subsection:

Do not disturb migratory bird nesting habitat (shrubs, trees, and structures), or clear vegetation from March 1 to September 1 of each year without prior written approval from the Engineer. Notify the Engineer, in writing, a minimum of 10 Calendar Days prior to starting activities that could harm nesting birds.

Add the following subsection:

**00290.42 Work Containment Plan** - A Work Containment Plan (WCP) is required on this Project for all activity(ies).

Develop and submit a WCP for approval at least 28 Calendar Days prior to mobilization for all activity(ies). Maintain a copy of the WCP on the Project Site at all times during construction, readily available to employees and inspectors. Ensure that all employees comply with the provisions of the WCP. Design the WCP to avoid or minimize disturbance to protected features (sensitive cultural or natural resources, regulated work areas, aquatic life or habitat in regulated work areas) related to Contractor operations.

Before developing the WCP, meet with Agency to review the Contractor's activities that require the WCP to ensure that all parties understand the locations of protected features to be avoided and the measures needed to avoid and protect them.

Notify the Engineer at least 10 Calendar Days before beginning work access or containment construction activities.

The Agency reserves the right to stop Work and require the Contractor to change the WCP methods and Equipment before any additional Contract Work, at no additional cost to the Agency, if and when, in the opinion of the Agency, such methods jeopardize sensitive cultural or natural resources, regulated work areas, or aquatic life or habitat in regulated work areas.

The WCP shall identify how the Contractor's construction operations will protect regulated features during mobilization, construction, maintenance, and demolition. Include a narrative describing compliance with Section 00290 as related to construction, operation, and demolition activities specified in Section 00253.

Design, construct, maintain, and remove temporary work access and containment systems according to Section 00253.

**00290.90 Payment** - Add the following paragraph(s) to the end of this subsection:

The work containment plan will be paid for at the Contract lump sum amount for the item "Work Containment Plan".

Payment will be payment in full for furnishing all Materials, Equipment, labor, and Incidentals necessary to complete the Work as specified. Payment includes providing and updating the Work Containment Plan.

## **SECTION 00296 - PAINT AND PAINTED MATERIALS**

Section 00296, which is not a Standard Specification, is included in this Project by Special Provision.

### **Description**

**00296.00 Scope** - In addition to the requirements of Section 00290, remove lead, chromium, and cadmium based paints, and materials coated with lead, chromium, and cadmium based paints, according to the following Specifications.

Lead, chromium and cadmium based paints coat the metal on the steel members on the Hood River Bridge. Assume the areas requiring paint removal contain lead, chromium, and cadmium and handle paint and painted materials accordingly.

**00296.03 Submittals** - Submit the following documents:

- A job specific written compliance program, according to 29 CFR 1926.62(e)(2), at least 10 Calendar Days before the pre-construction conference. When applicable, include compliance procedures for cadmium and chromium VI, according to 29 CFR 1926.1127 and 29 CFR 1926.1126.
- Modifications to the written compliance program within 7 Calendar Days of the modifications.
- Current employee training certificates and medical surveillance information before beginning work that disturbs paint containing lead, cadmium or chromium.
- Within 48 hours of completing or receiving them:
  - Disposal and recycling facility permits.
  - Transport manifests and bill-of-ladings.
  - All reuse, recycling, and disposal receipts.
  - All analytical test results.

**00296.04 Documentation** - Include paint and painted materials management and planned reuse, recycling, and disposal information in the pollution control plan. Obtain Engineer approval for the specific reuse, recycling, and disposal methods for all materials before beginning demolition work.

Complete, sign and pay all required fees for all required permits, manifests, and bill-of-lading forms for transport and disposal of the paint and painted materials.

### **Labor**

**00296.30 Personnel Qualifications** - Provide employees trained in lead awareness, according to 29 CFR 1926.62(l), and also trained according to 29 CFR 1926.1126(j)(2) for chromium and 29 CFR 1926.1127(m)(4) for cadmium, during demolition of painted portions of the structures.

### **Construction**

**00296.40 Handling** - Minimize employee exposure to the metals contained in the paint. Provide containment that prevents release of paint chips to the environment. Do not remove or separate paint from painted substrates, unless required to accomplish repair activities.

**00296.43 Painted Metal Management** - Reuse, recycle, or dispose of painted metal according to any of the following:

- **Reuse by Others** - Provide or sell painted non-structural scrap metal to the following:
  - Provide to ODOT for use on other projects.
  - Provide to ODOT Maintenance Section.
  - Provide or sell to other government Agencies.
  - Provide or sell to contractors for their reuse.

Obtain the recipients signature on the attached disclaimer form, acknowledging their awareness that the scrap metal contains lead, chromium, and cadmium based paint before giving them possession.

- **Recycle at Recycling Facility** - Transport the painted scrap metal along with the paint analytical results to a recycling facility. Obtain the recipients signature on the attached disclaimer form, acknowledging their awareness that the scrap metal contains lead, chromium and cadmium based paint.
- **Dispose of at Landfill** - Dispose of the painted scrap metal at a permitted municipal solid waste landfill or a permitted construction and demolition landfill.

**00296.46 Hazardous Waste Paint Management** - When hazardous waste paint is separated from its substrate, store all the separated paint waste in labeled, sealed, watertight containers and handle the hazardous waste according to 00290.20(d).

#### **Measurement**

**00296.80 Measurement** - No measurement of quantities will be made for Work performed under this Section.

#### **Payment**

**00296.90 Payment** - No separate or additional payment will be made for Work performed under this Section. Payment will be included in payment made for the appropriate items under which this Work is required.



**Attachment A**  
**Lead, Chromium, and Cadmium Based Paint Acknowledgement Form**

[Contractor] \_\_\_\_\_  
[Bridge Identification] \_\_\_\_\_  
[Description of Scrap Metal] \_\_\_\_\_

\_\_\_\_\_ [Recipient] acknowledges that they are aware that metal and materials received from \_\_\_\_\_ [Contractor] on \_\_\_\_\_ [Date(s)] may contain lead, chromium, or cadmium based paint. Recipient further acknowledges that it is aware of the risk to human health and the environment posed by exposure to lead, chromium and cadmium based paint. All storage, use, sale, and disposal of materials containing lead, chromium or cadmium based paint and any removal of lead, chromium, or cadmium based paint from the materials by Recipient will be conducted in compliance with all applicable Federal and State statutes and regulations, including but not limited to 40 CFR 262 through 265 and OAR Chapter 340, Divisions 100 through 106. Recipient acknowledges that they are solely responsible for any liability or damages resulting from the storage, use, sale, and disposal of the materials and removal of lead, chromium or cadmium based paint by Recipient and Recipient will indemnify and hold harmless the Contractor and the Oregon Department of Transportation from any such claims of liability or damages.

\_\_\_\_\_ [Signature]  
\_\_\_\_\_ [Title]  
\_\_\_\_\_ [Date]

## SECTION 00542 - CONCRETE REPAIR

Section 00542, which is not in the Standard Specifications, is included in this Project by Special Provision.

### Description

**00542.00 Scope** - This Work consists patching and repairing a damaged joint header and preparing and sealing cracks in the top of concrete piers.

**00542.01 Submittals** - Submit the following at least 21 Calendar Days before beginning concrete repair Work according to 00150.37. Within 21 Calendar Days after receipt of submittals, the Engineer will review the submittals and designate them in writing as "approved", "approved as noted", or "returned for correction".

(a) **Joint Header Repair** – Submit preparation methods and patching material to be used for header repair.

(b) **Pier Crack Sealing** – Submit preparation methods and sealant material to be used.

### Materials

#### 00542.10 Materials:

Provide grout for joint header patching from the approved qualified products list per Section 02080.10 or 02080.20. Grout shall be non-shrinking with a minimum 28-day compressive strength of 5000 psi. Use material that will cure prior to being re-opened to traffic.

Steel angle to be ASTM A36 or better if replacement is necessary.

Provide a silicone sealant designed for bonding to and sealing concrete and resistant to ultraviolet exposure.

### Labor

**00542.30 Welders** - Provide certified welders and welding inspectors according to AWS D1.5.

### Construction

**00542.40 Work Access, Containment, and Disposal** - Provide Work access and debris containment according to Section 00253.

Dispose of waste according to 00290.20.

**00542.41 Concrete Removal** - Saw-cut the boundaries of concrete to be removed, to a depth just missing the reinforcing bars with less than 1/2 inch concrete cover or to a minimum of 1/2 inch, whichever is less. Saw cuts shall not overrun at the corners of the marked boundaries. Saw cutting is not required if the Contractor can consistently provide, by another technique, a minimum 1/2 inch deep excavation surface that is uniformly perpendicular to the original concrete surface along the marked boundary.

Remove concrete within the repair area with high-pressure waterjet blasting Equipment, pneumatic hammers, chipping guns, manual picks and chisels, or other Equipment approved by the Engineer. Do not use pneumatic hammers heavier than a nominal 15-pound class. Remove concrete in such a way that removal of sound concrete beyond established boundaries is kept to a minimum. When working around reinforcing bars, avoid loosening the reinforcement or fracturing the concrete around it beyond the repair area.

Remove all Damaged Concrete within the repair area to the depth of sound concrete. Provide a minimum of 1/2" patch material thickness beneath the steel angle header.

**00542.42 Surface Preparation** - Prepare surfaces that are to receive patching material with a surface profile according to International Concrete Repair Institute (ICRI) Guideline 310.2R-2013 surface profile CSP 6 (1/8 inch surface profile) or manufacturer's recommendations if appropriate.

**00542.43 Patch Installation:**

Saturate prepared surfaces prior to placing grout. Install steel header segment prior to initial set and tack weld in place. After full set, weld steel header joints full length prior to opening to traffic.

**00542.44 Crack Sealing** – Prepare cracks to create a “v” or “u” shaped groove along length of crack to be sealed. Brush clean surface to remove loose particles. Apply silicone sealant and finish to provide a convex profile above adjacent surface.

**Measurement**

**00542.80 Measurement** - The quantities of Work performed under this Section will be measured according to the following:

Measurement of Joint Header Repair will be on the unit basis of each repair location.

Measurement of Pier Crack Sealing will be on the unit basis of each pier with repairs.

**Payment**

**00542.90 Payment** - The accepted quantities of Work performed under this Section will be paid for at the Contract unit price per unit of measurement for the following item(s):

<b>Pay Item</b>	<b>Unit of Measurement</b>
(a) Joint Header Repair .....	Each

(b) Pier Crack Sealing .....Each Pier

Payment will be payment in full for furnishing and placing all Materials, and for furnishing all Equipment, labor, and Incidentals necessary to complete the Work as specified.

### SECTION 00560 - STRUCTURAL STEEL BRIDGES

Comply with Section 00560 of the Standard Specifications modified as follows:

**00560.00 Scope** – Add the following:

Work is limited to stringer to floorbeam repairs, substringer to stringer repairs, guardrail post to stringer repairs, floorbeam knee brace repair, truss chord repair, rocker bearing modifications, replacing rivets or bolts, or tightening bolts.

The work includes removal of existing coating from rivets, welds, and existing member surfaces adjacent to removal limits, Surface preparation work, and coating of the affected areas. The existing coatings are assumed to contain lead and chromates.

**00560.25(a) Straightening** - Replace this subsection, except for the subsection number and title, with the following:

Straighten bent or distorted plates, angles, and other shapes or built-up members according to AWS D 1.5, and as specified.

**00560.25(c)(2) Flame Cutting** - Replace this subsection, except for the subsection number and title, with the following:

Flame cut structural steel according to AWS D1.5, and as specified.

**00560.25(c)(3) Visual Inspection and Repair** - Replace this subsection, except for the subsection number and title, with the following:

Visually inspect and repair plate cut edges according to AWS D1.5, and as specified.

**00560.29(d) Verification Testing, Installation, and Inspection** - Replace Table 00560-1 with the following:

**Table 00560-1  
Required Fastener Tension in Bolts**

<b>Nominal Bolt Size (inch)</b>	<b>Minimum Tension (kips)</b>
1/2	12
5/8	19
3/4	28
7/8	39
1	51

1 1/8	64
1 1/4	81
1 3/8	97
1 1/2	118

**00560.29(d)(1) Direct Tension Indicator Tightening** - Delete this subsection.

**00560.30 Fabricators** - Replace this subsection, except for the subsection number and title, with the following:

Structural steel Bridge fabricators shall have an American Institute of Steel Construction (AISC) Certified Bridge Fabricator - Intermediate (IBR) certification. For fracture critical Structures, the fabricator shall also have an AISC Fracture Critical Endorsement (FC). All fabricators of earthquake restraints shall have either a current AISC IBR certification or a Certified Bridge Fabricator - Simple (SBR) certification.

Add the following subsection:

**00560.47 Rivet and Bolt Replacement** – The rivets to be removed shall be removed using a pneumatic “rivet buster” with “mole” punch, or other approved method. Do not damage structural steel surfaces or bore of holes.

Before rivet removal, remove existing coating from rivet heads and 1/2" zone around rivet head by power tool cleaning in accordance with Section 00594.42(c). Should existing coating removal result in wholesale coating removal, do not remove additional coating beyond the 1/2" zone around the rivet head in order to search for sound coating. Hand sand the periphery and perform repairs on a best effort basis. Contain debris from coating removal operations by using vacuum shrouded power tools and tarps according to Sections 00290 and 00594.

When fasteners are removed, power tool clean surfaces and holes in accordance with SSPC-SP-15 (use metal wire deburring brushes or tube brushes as necessary) and apply a zinc-rich primer to the fastener hole, the area under the new fastener washer, and the 1/2" zone where the existing coating was removed prior to rivet removal. The zinc-rich primer shall be compatible with the coating system selected in accordance with Section 00594.

Replace fasteners that are removed, or to be replaced, with ASTM F3125, Grade A325 or Grade F1852 galvanized bolts with ASTM A563 Heavy Hex galvanized nuts and ASTM F436 galvanized washers, installed in accordance with Section 00560.29. After installation of the new fasteners, prepare the new fasteners per 00594.42(d)(1) and coat the new fasteners and 1/2" zone per 00594.43.

Use galvanized beveled plate washers matching the slope of channel flanges, or other members as needed, to square up bolted connections.

Add the following subsection:

**00560.48 Weld Removal** – Remove welds by grinding or cutting without causing damage or reduced section to the member to remain. Grind remaining weld metal to be flush with the remaining member.

Before weld removal, remove existing coating from welds and 1/2" zone around welds by power tool cleaning in accordance with Section 00594.42(c). Should existing coating removal result in wholesale

coating removal, do not remove additional coating beyond the zone noted in plans in order to search for sound coating. Hand sand the limits and perform repairs on a best effort basis. Contain debris from coating removal operations by using vacuum shrouded power tools and tarps according to Sections 00290 and 00594.

Add the following subsection:

**00560.49 Stringer Connection Repair** – Provide the following connection repairs as shown and described in the plans:

- Replace or install bolts at stringer to floorbeam connections.
- Grind cracked welds, drill hole and install bolt at substringer to stringer connections.
- Grind cracked weld, drill hole and install bolt at guardrail post to stringer connection.

Add the following subsection:

**00560.50 Floorbeam Knee Brace Repair** – Floorbeam knee brace connections may only be removed in areas restricted from traffic and must be replaced prior to area being opened to traffic. If permanent installation cannot be completed in one shift then provide a temporary connection during traffic exposure.

Add the following subsection:

**00560.51 Light Pole Connection Repair** – Replace or tighten bolts at light pole connection as shown in the plans.

Add the following subsection:

**00560.52 Debris Removal** – Remove deposited material from stringers, floorbeams, and truss top chord members at locations shown in the plans. Take care to keep material from entering the river.

Add the following subsection:

**00560.53 Rocker Bearing Modification** – Protect cast rocker bearing steel from heat above 1100 degrees Fahrenheit. Gusset plate sections to be removed shall be torch cut or by other approved method.

Add the following subsection:

**00560.54 Truss Chord Repair** – Remove loose bolts and remnant of connection plate, replace bolts with galvanized high strength bolts as shown in the plans.

**00560.80 Measurement** - Replace this subsection, except for subsection number and title, with the following:

Measurement of Stringer Connection Repair will be on the unit basis of each connection location.

Measurement of Floorbeam Knee Brace Repair will be on the unit basis of each knee brace repaired.

Measurement of Light Pole Connection Repair will be on the unit basis of each light pole repaired.

No measurement of quantities will be made for Debris Removal.

Measurement of Rocker Bearing Modification will be on the unit basis of each bearing modified.

Measurement of Truss Chord Repair will be on the unit basis of each repair location.

**00560.90 Payment** – Add the following to this subsection:

<b>Pay Item</b>	<b>Unit of Measurement</b>
(i) Stringer Connection Repair	Each
(j) Floorbeam Knee Brace Repair	Each
(k) Light Pole Connection Repair	Each
(l) Debris Removal	Lump Sum
(m) Rocker Bearing Modification	Each
(n) Truss Chord Repair	Each

Payment will be payment in full for furnishing and placing all Materials, and for furnishing all Equipment, labor, and incidentals necessary to complete the Work as specified.

## **SECTION 00594 - PREPARING AND COATING METAL STRUCTURES**

Comply with Section 00594 of the Standard Specifications modified as follows:

**00594.00 Scope** - Replace this subsection, except for the subsection number and title, with the following:

This Work consists of preparing and coating existing or new steel on Bridge No. 06645 (Hood River-White Salmon Interstate Bridge) as shown in the plans.

Lead-based coatings will be affected by the preparation and coating Work.

Coatings that contain chromates will be affected by the preparation and coating work.

**00594.01(b) Definitions** - Replace the definition for “Maintenance Coating” with the following:

**Maintenance Coating** - The coating of existing steel Structures that have been previously coated and need recoating. Maintenance Coating is not considered Rehabilitation Work.

Add the following definition:

**Rehabilitation** - Work performed on a Structure to restore or improve load carrying capacity, serviceability, or maintenance and inspection access.

Replace the definition for “Stripe Coat” with the following:

**Stripe Coat** - A separate, independent coating that is applied to complex details and irregular surfaces.

**00594.05 Waste Handling and Disposal** - Add the following paragraph to the end of this subsection:

When lead is contained in the waste, dispose of waste material according to 00290.20, Section 00296, and the applicable requirements of SSPC-Guide 7.

**00594.10 Materials** - Add the following to the end of the subsection:

Furnish a maintenance coating, 3 coat system with organic zinc primer from the QPL. Provide top-coat color that conforms to #24272 of SAE AMS-STD-595.

**00594.11(c) Sampling and Testing** - Replace the four bullets with the following three bullets:

- Test results certification according to 00165.35 for each batch of each coat, and if the coating material is specified for use on steel-to-steel contact surfaces, certification that the coating material meets the requirements of 00594.11(d).
- A product data sheet for each type of coating material.
- A material safety data sheet or safety data sheet with the initial sample of each type of coating material.

Replace the paragraph beginning “Agency testing will include the following tests...” with the following:

Agency testing may include the following tests necessary to ensure that the coating materials conform to Specifications, manufacturer's product data sheet, and other testing as the Agency deems appropriate.

**00594.40(b) Existing Steel Structures** - Add the following paragraphs and bullets to the end of this subsection:

Prepare and coat the following surfaces:

- Existing steel surfaces according to 00560.47 to 00560.53.
- New steel members to be shop coated.
- Exposed bare surfaces of existing steel remaining after removing, cutting, drilling, or reaming.

**00594.42(c) Rehabilitating Existing Coated Steel Structures** - Replace this subsection with the following subsection:

**00594.42(c) Rehabilitation of Existing Steel Structures** - When performing rehabilitation on a Structure which is not receiving a Maintenance Coating outside the immediate area of the rehabilitation details, prepare all existing steel surfaces to be coated according to SSPC-SP 15, Commercial Grade Power Tool Cleaning. Provide a cleaned surface with a minimum surface profile of 1 mil.

Prepare all existing coated surfaces exposed by the removal of the existing components involved in the rehabilitation, all areas in which rivets, bolts, or plates are to be removed, and areas damaged by erection or other Contractor operations. Completely clean all existing lead-based coatings exposed by the removal of any structural or miscellaneous member to SSPC-SP 15 *Commercial Grade Power Tool Cleaning* requirements. Extend all prepared areas at least 2 inches into tightly adhering, intact



paint. Overlap the subsequent coating and the still intact coating by a minimum of 2 inches. Lightly sand the overlap area of the intact coating to provide a profile for the subsequent repair coating to adhere to.

**00594.43(c)(2) Application Methods** - Add the following paragraphs after the paragraph beginning "Apply coating materials by air or airless spray..."

Augment the initial primer application using brushes. Immediately upon transfer of the liquid coating to the substrate, work coating by brush into all areas that are usually stripe coated as identified by SSPC Paint Application Guide No. 11.

If rust back, rust bloom, or rust stains are present on the surface after brush augmented primer application, re-prepare the surface according to 00594.42 and resubmit the primer application procedure to the Engineer.

**00594.43(d)(2) Stripe Coats** - Replace this subsection, except subsection number and title, with the following:

Apply a prime stripe coat by brush after applying the full brush augmented prime coat and apply an intermediate stripe coat by brush before applying the full intermediate coat. For two coat paint systems, except non-ferrous coating systems from the QPL, apply a top coat stripe coat prior to full top coat application. Apply the stripe coat by brush only. Use brushes to push the coating around and into complex details and irregular surfaces identified as usually stripe coated by SSPC Paint Application Guide No. 11. Make each stripe coat a different color than the preceding and subsequent full coat, extending a minimum of 1 inch from the irregular surface, and completely hiding the substrate. The stripe coat shall be a different color and be approximately 3 mils thick. Each stripe coat will have its own hold point and shall not be used to correct deficiencies in the preceding or subsequent coats. Apply stripe coats according to the applicable sections of SSPC Paint Application Guide No. 11 that do not conflict with this Section or the Special Provisions.

A prime stripe coat may be applied prior to a full prime coat without brush augmentation other than what is necessary to achieve full coverage provided both coats are applied on the same Calendar Day as surface preparation.

**00594.43(f) Caulking** - Replace this subsection, except subsection number and title, with the following:

Apply clear or color matched caulk after complete application of the top coat. If opaque caulk cannot be supplied in a color that approximates the top coat color, apply after intermediate coat application, but before top coat application following all manufacturer recommended curing schedules.

Fill and seal crevices and gaps between structural shapes and plates, around bolt heads and nuts, weld terminations, and similar areas that would retain moisture, with the following:

- Caulk, if the crevice or gap cannot be filled with coating materials.
- Backing material and caulk to fill the crevices and gaps that exceed 1/4 inch.
- Apply caulk over the backing material to form a watertight seal.
- In areas that collect or channel water, apply caulk even if coating fills the gap.

Do not caulk the bottom edge of vertical connections, horizontal built up members, or other connection details where caulking bottom surfaces may trap moisture.

**00594.43(g) Adhesion** - Replace this subsection, except subsection number and title, with the following:

Adhesion testing will not be required.

**00594.60(c) Coating Application in Repair Areas** - Replace the paragraph beginning "When the bare metal substrate..." with the following:

When the bare metal substrate is exposed in the repair area apply all coats of the coating system, including stripe coats where applicable, to the specified thicknesses.

**00594.90 Payment** - Replace this subsection, except for the subsection number and title, with the following:

No separate payment will be made for preparing and coating existing or new metal Work. Payment for this Work, including correction of damages, will be included in payment made for appropriate items under which this Work is required.

## **SECTION 02530 - STRUCTURAL STEEL**

Comply with Section 02530 of the Standard Specifications modified as follows:

**02530.10 Structural Steel for Bridges** - Replace this subsection, except for the subsection number and title, with the following:

Structural steel for Bridges shall conform to the following, as shown or specified:

- AASHTO M 270, Grade 36 (ASTM A709, Grade 36)
- AASHTO M 270, Grade 50 (ASTM A709, Grade 50)
- AASHTO M 270, Grade 50W (ASTM A709, Grade 50W)
- AASHTO M 270, Grade HPS 70 (ASTM A709 Grade HPS 70)
- AASHTO M 270, Grade HPS 70W (ASTM A709 Grade HPS 70W)

Impact test requirements, for both non-fracture-critical tension components (T), and fracture-critical tension components (F), are to be according to Zone 2 requirements of AASHTO M 270 Tables 11 and 12, respectively.

**PART 10**  
**CONSTRUCTION PLANS**  
**BOUND SEPERATELY**

**PART 11**

**PORT OF HOOD RIVER  
PUBLIC IMPROVEMENT CONTRACT  
(Sample)**

**PORT OF HOOD RIVER  
PUBLIC IMPROVEMENT CONTRACT**

This Contract entered into between the PORT OF HOOD RIVER, an Oregon municipal corporation, ("PORT") and \_\_\_\_\_ ("CONTRACTOR"), shall become effective when this Contract has been signed by both parties and the Port has issued to CONTRACTOR a Notice to Proceed with the Work.

**WITNESSETH:**

**WHEREAS**, CONTRACTOR, having examined the Work site and become familiar and satisfied with conditions, has submitted an acceptable bid for Miscellaneous Truss Repairs for the Hood River Bridge at Hood River, Oregon 97031 ("Work"); and,

**WHEREAS**, the parties hereto desire that this Contract be undertaken and completed on the terms and conditions as hereafter set forth;

**THEREFORE, IT IS AGREED AS FOLLOWS:**

**Terms of Performance**

CONTRACTOR agrees to perform the described Work and provide all machinery, tools, apparatus, materials, equipment, labor and other means of construction necessary to complete the Work at the designated location in accordance with all terms specified in the Contract Documents, which by this reference are incorporated herein, including the following:

- A) Invitation to Bid
- B) Bidding Instructions
- C) First-Tier Subcontractor Disclosure Form
- D) Bid Form/Bid Schedule
- E) Bid Bond
- F) Performance Bond
- G) Payment Bond
- H) Certificate of Insurance
- I) General Conditions of Public Works Contracts
- J) Notice of Intent to Award
- K) Notice to Proceed
- L) Payment of Prevailing Wages Rates
- M) Drawings prepared for/or issued by PORT
- N) Specifications prepared for/or issued by PORT
- O) All affidavits and certifications submitted by CONTRACTOR as part of CONTRACTOR's Bid Documents, which affidavits and certifications CONTRACTOR agrees will remain effective throughout the term of this Contract.

**Contract Price:**

Subject to the provisions of all Contract Documents and in consideration of the faithful performance of the terms and conditions thereof by the CONTRACTOR, PORT agrees to pay CONTRACTOR \_\_\_\_\_, in the manner and at the times provided in the Contract Documents. The Contract price is for completing the Work. No alternates are included.

**Contract Dates:**

Project Start Date: 10 calendar days from issuance of Notice to Proceed.  
Substantial Completion: August 25, 2023  
Final Completion: September 15, 2023

**Liquidated damages**

If the CONTRACTOR fails to complete the Work within the time specified or within any extension of time agreed to by both parties in writing, CONTRACTOR shall pay liquidated damages of \$250.00, for each day of delay beyond the completion day identified above. (If no dollar amount is specified this paragraph shall not apply to this Contract.)

**Representatives**

Unless otherwise specified in the Contract Documents, the Port designates John Mann, as its Authorized Representative in the administration of this Contract. The above-named individual shall be the initial point of contact for matters relating to performance, payment, authorization, and to carry out the responsibilities of the Port. Contractor has named \_\_\_\_\_ its Authorized Representative to act on its behalf.

**Integration**

The Contract Documents and this Contract constitute the entire agreement between the parties. No waiver, consent, modification or change of terms of this Contract shall bind either party unless in writing and signed by both parties. Such waiver, consent, modification or change, if made, shall be effective only in the specific instance and for the specific purpose given. There are no other understandings, agreements, or representations, oral or written, not specified herein regarding this Contract. Contractor, by the signature below of its authorized representative, hereby acknowledges that it has read this Contract, understands it, and agrees to be bound by its terms and conditions.

IN WITNESS WHEREOF the parties have executed this Contract on \_\_\_\_\_, 20\_\_.

\_\_\_\_\_  
**CONTRACTOR**

\_\_\_\_\_  
**PORT OF HOOD RIVER**

By \_\_\_\_\_

By \_\_\_\_\_

Its \_\_\_\_\_

Its \_\_\_\_\_

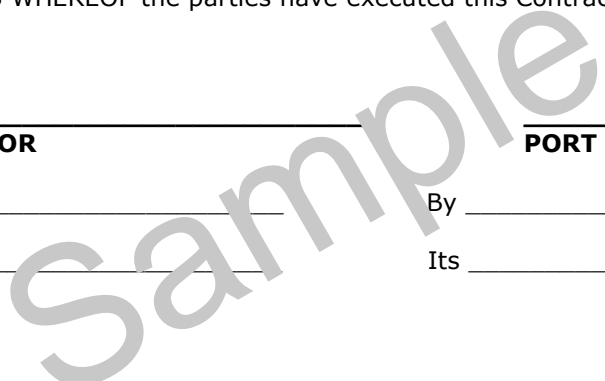

# PORT OF HOOD RIVER COMMISSION HOOD RIVER, OREGON

PLANS FOR PROPOSED PROJECT

## HOOD RIVER INTERSTATE BRIDGE MISCELLANEOUS TRUSS REPAIRS HOOD RIVER - WHITE SALMON HWY.

HOOD RIVER, OR. AND KLICKITAT, WA. COUNTIES

MARCH 2023

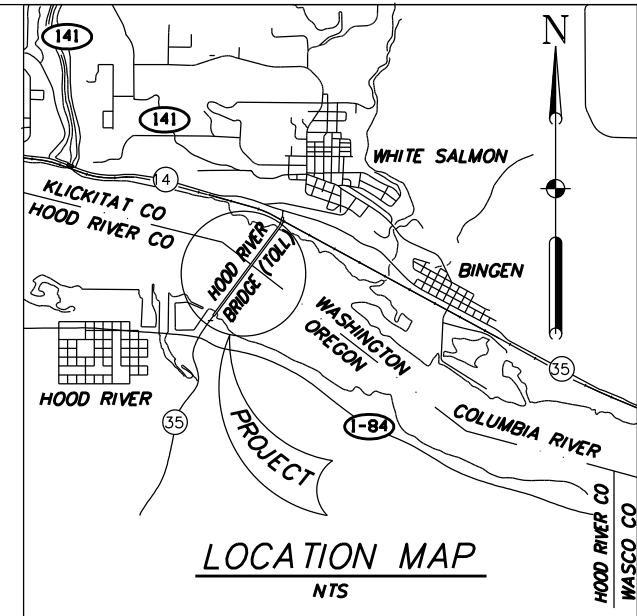

**General Notes**

1. Conform to the "Oregon Standard Specification for Construction" 2021 and the Project Special Provisions for all materials and workmanship.
2. See Special Provisions for traffic control requirements.
3. The dimensions shown on the plans are based on drawings of the existing structure and are assumed to be approximate. Field verify all dimensions and field fit conditions.
4. Furnish all structural steel conforming to ASTM A36.
5. Furnish 3/4" diameter galvanized high-strength bolts conforming to ASTM F3125, Grade A325, or F1852. Tighten bolts in accordance with the Specifications. All high-strength bolted connections are slip critical, unless otherwise noted.
6. Conform to AWS D1.5 for all welds.
7. Design and provide work containment system, work access, and work platform systems per Special Provisions.
8. Do not scale dimensions from the plans.

PROJECT PLANS	
SHEET NO.	DESCRIPTION
1	TITLE SHEET & GENERAL NOTES
2	GENERAL ELEVATION
3	STRINGER CONNECTION REPAIRS
4	FLOORBEAM & CHORD SPLICE REPAIRS
5	LIGHT POLE & DEBRIS REMOVAL DETAILS
6	ROCKER BEARING & JOINT HEADER REPAIRS
7	PIER CRACK SEALING DETAILS
ODOT STANDARD DRAWINGS	
DWG. NO.	DESCRIPTION
-----	-----

▲	DATE	REVISION	BY	DRAFTER: <i>E. Gahan</i>	   	STRUCTURE NO. 06645	<b>HOOD RIVER INTERSTATE BRIDGE MISCELLANEOUS TRUSS REPAIRS HOOD RIVER-WHITE SALMON HIGHWAY HOOD RIVER, OR &amp; KLICKITAT, WA COUNTIES</b>	SHEET 1 OF 7	
				DESIGNER: <i>M. Libby</i>		DATE March 2023		TITLE SHEET & GENERAL NOTES	DRAWING NO.
				CHECKER: <i>S. Timilsina</i>		CALC. BOOK			110209
ACCOMPANIED BY DWGS.				REVIEWER: <i>M. Mitchell</i>		RENEWS: 12-31-2024			

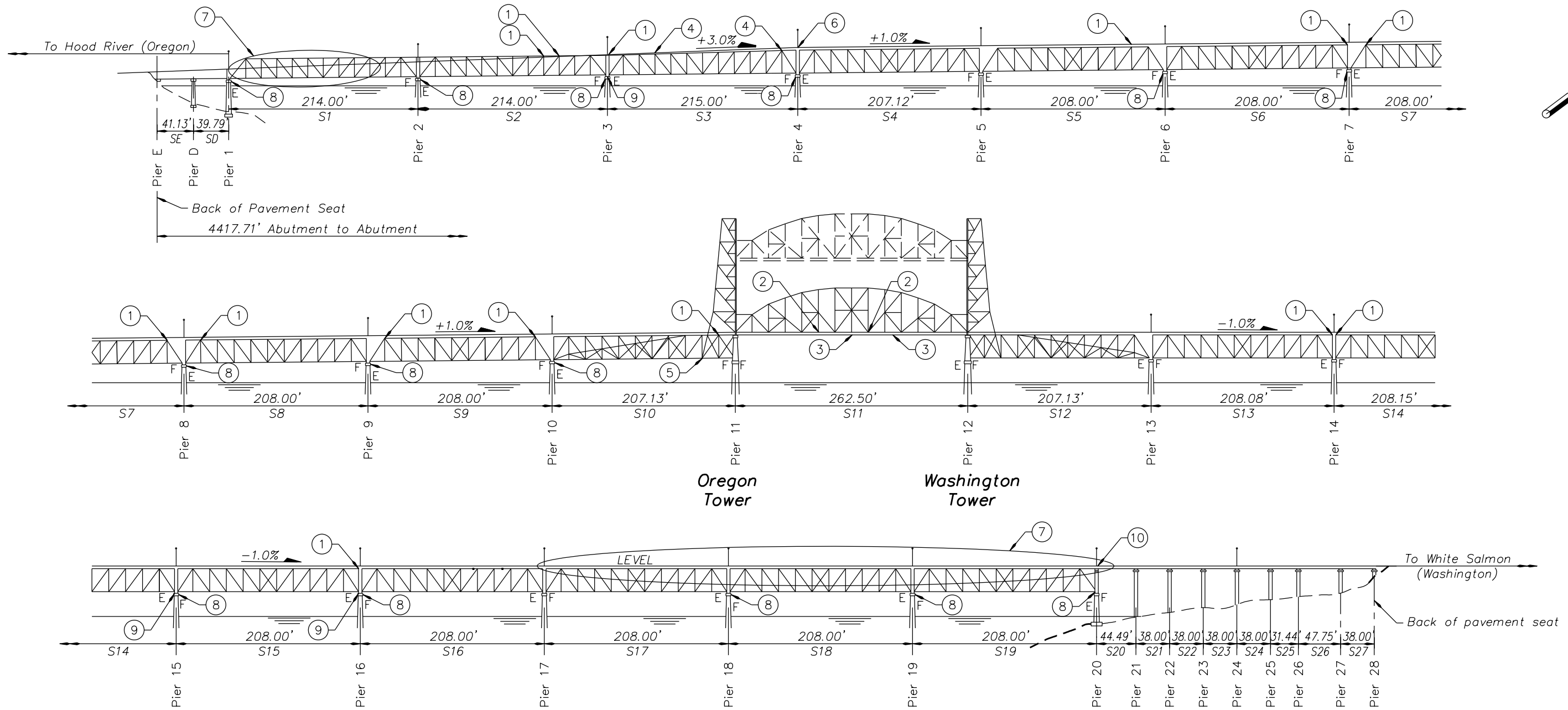

**BRIDGE ELEVATION**

Scale: NTS  
 (East side of bridge shown, looking west)  
 (West side similar except as noted)

Legend	
S1	- Denotes span number
NTS	- Denotes "Not to Scale"
E	- Denotes expansion bearing
F	- Denotes fixed bearing

**Work Items:**

- ① - Stringer to floorbeam connection, see Sheet 3. (15 locations)
- ② - Substringer to stringer connection, see Sheet 3. (2 locations)
- ③ - Guardrail post to stringer connection, see Sheet 3. (2 locations)
- ④ - Floorbeam knee brace repair, see Sheet 4. (2 locations)
- ⑤ - Truss chord repair, see Sheet 4. (1 location)
- ⑥ - Replace, tighten light pole bolts, see Sheet 5. (1 location)
- ⑦ - Debris removal, see Sheet 5.
- ⑧ - Clean and seal cracks, see Sheet 7. (14 locations)
- ⑨ - Rocker bearing modifications, see Sheet 6. (5 locations)
- ⑩ - Joint header repair, see Sheet 6. (1 location)

DATE	REVISION	BY	STRUCTURE NO.	<b>HOOD RIVER INTERSTATE BRIDGE                  MISCELLANEOUS TRUSS REPAIRS                  HOOD RIVER-WHITE SALMON HIGHWAY                  HOOD RIVER, OR &amp; KLICKITAT, WA COUNTIES</b>	SHEET
		DRAFTER: <i>E. Gahan</i> DESIGNER: <i>M Libby</i> CHECKER: <i>S. Timilsina</i> REVIEWER: <i>M. Mitchell</i>	06645 DATE March 2023 CALC. BOOK		2 OF 7
ACCOMPANIED BY DWGS.			GENERAL ELEVATION		DRAWING NO. 110210





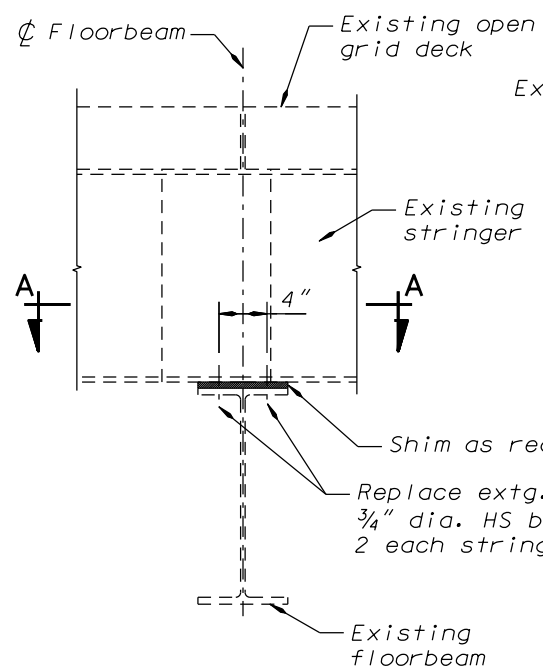

**REPAIR DETAIL 1 - STRINGER TO FLOORBEAM CONNECTION**  
Scale: NTS

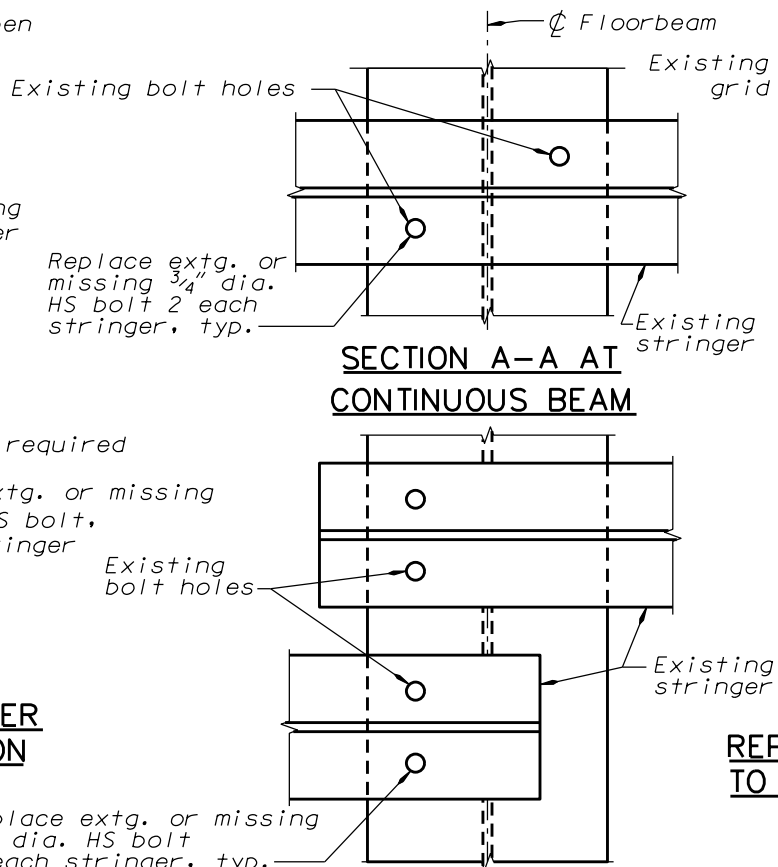

**SECTION A-A AT BEAM ENDS**  
Scale: NTS

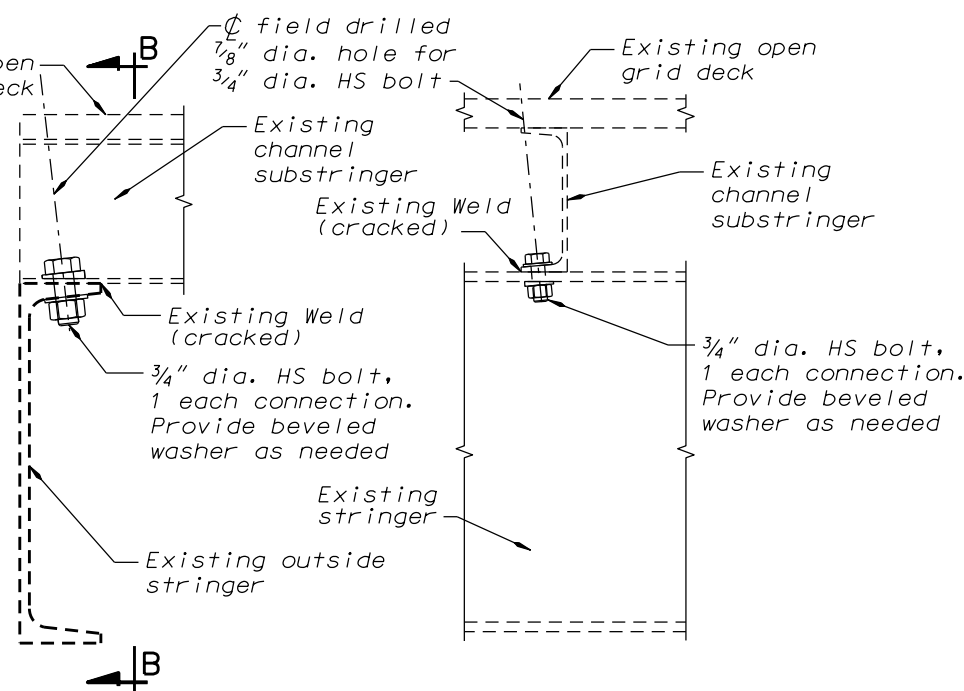

**REPAIR DETAIL 2 - STRINGER TO SUBSTRINGER CONNECTION**  
Scale: NTS

**SECTION B-B**  
Scale: NTS

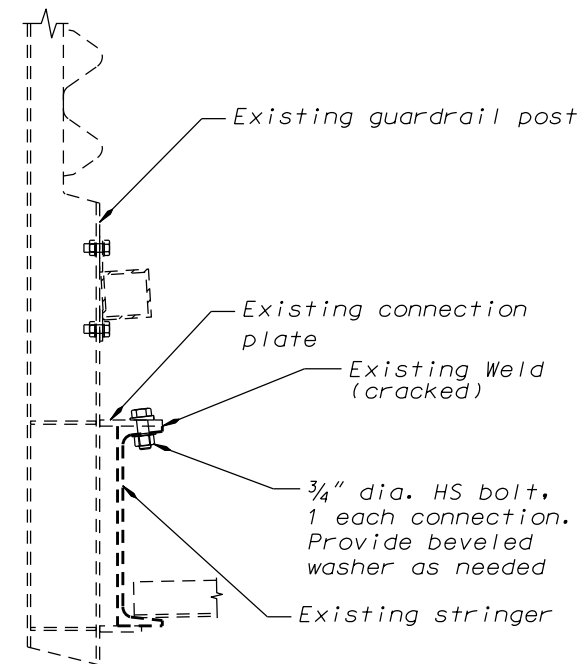

**REPAIR DETAIL 3 - GUARDRAIL POST TO STRINGER CONNECTION**

**Note:**

Stringer ends are assumed to have two holes and one bolt or none. If only one hole exists place one bolt, if two holes exist place two bolts.

**Construction Notes for Repair Detail 1:**

1. Replace missing shim plates. Field measure and verify size and thickness of shim required.
2. Field match and drill holes in new shim plate.
3. Apply prime and intermediate coats to new shims or hot dip galvanize.
4. Remove existing bolts, if present.
5. Adjust rotated shim plates, or replace missing shim plates, as needed.
6. Clamp stringer to be in firm contact with shim plate and floorbeam. Install new bolts till snug and tack weld nut to prevent loosening.

**Construction Notes for Repair Detail 2 & 3:**

1. Remove paint at weld and on surface to be drilled.
2. Grind out any portion of weld still intact.
3. Field drill hole in flange of existing channels and plates at each location indicated. Provide beveled plate washer as required for full bearing.
4. Apply prime and intermediate coats.
5. Install new galvanized HS bolts, nut and beveled washers.
6. Apply top coat.

REPAIR LOCATIONS				
SPAN	STRINGER*	LOCATION	REPAIR DETAIL NO.	NOTES
2	3	FB9	1	ROTATED SHIM
2	4	FB8	1	ROTATED SHIM
3	3	FBO	1	MISSING BOLT
5	3	FB9	1	ROTATED SHIM
6	2	FB11	1	ROTATED SHIM
7	4	FB1	1	MISSING SHIM
7	2	FB10	1	MISSING SHIM AND BOLT
8	2	FB1	1	MISSING BOLT
9	2	FB1	1	MISSING SHIM
9	4	FB10	1	MISSING BOLT
10	4	FB10	1	MISSING SHIM
11	1	FB5±	2	CRACKED WELD
11	1	FB8±	2	CRACKED WELD
11	1	PP7±	3	CRACKED WELD
11	6	PP9-PP10	3	CRACKED WELD
13	2	FB11	1	CRACKED WASHER
14	4	FBO	1	ROTATED SHIM
15	2	FB11	1	ROTATED SHIM, MISSING BOLT
15	3	FB11	1	ROTATED SHIM

\*Stringer 1 indicates west most stringer

\*\*FBO is south most floorbeam; PPO is south most truss panel point

	DRAFTER: E. Gahan DESIGNER: M. Libby CHECKER: S. Timilsina REVIEWER: M. Mitchell				STRUCTURE NO. 06645	HOOD RIVER INTERSTATE BRIDGE MISCELLANEOUS TRUSS REPAIRS HOOD RIVER-WHITE SALMON HIGHWAY HOOD RIVER, OR & KLICKITAT, WA COUNTIES	SHEET 3 OF 7
	ACCOMPANIED BY DWGS.				DATE March 2023 CALC. BOOK		STRINGER CONNECTION REPAIRS

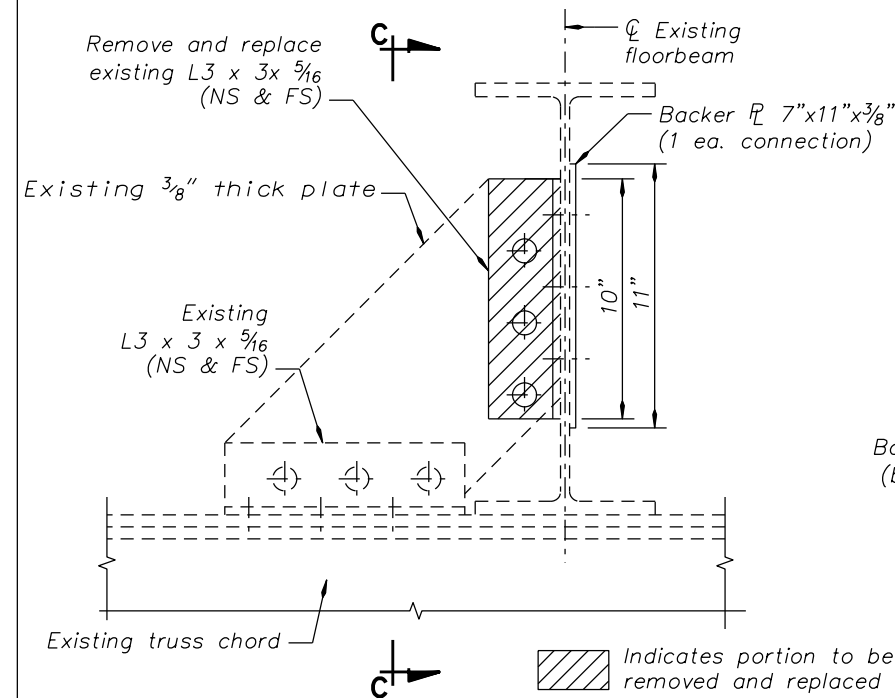

**REPAIR DETAIL 4 – FLOORBEAM KNEE BRACE REPAIR**  
Scale: NTS

Construction Notes for Repair Detail 4:

1. Field measure and verify dimensions of replacement angle.
2. Remove paint coating as needed to remove existing rivets and angles.
3. Field match and drill holes in replacement angles and backer plate.
4. Apply prime and intermediate coats.
5. Install new angles, backer plate and bolts.
6. Apply top coat.

Construction Notes for Repair Detail 5:

1. Remove paint coating as needed to remove existing bolts and connection plate remnant.
2. Apply prime and intermediate touch-up coats as needed.
3. Install new HS bolts.

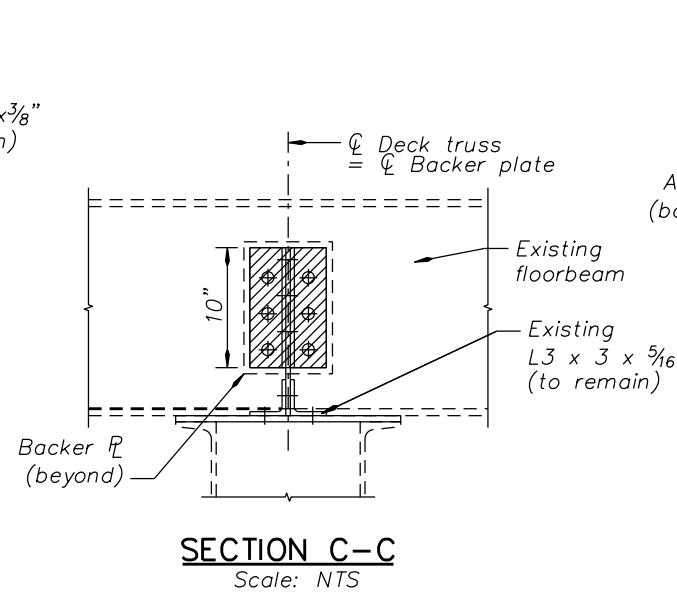

Existing connection plate remnant and loose bolts to be removed. Replace bolts with 3/4" HS bolts

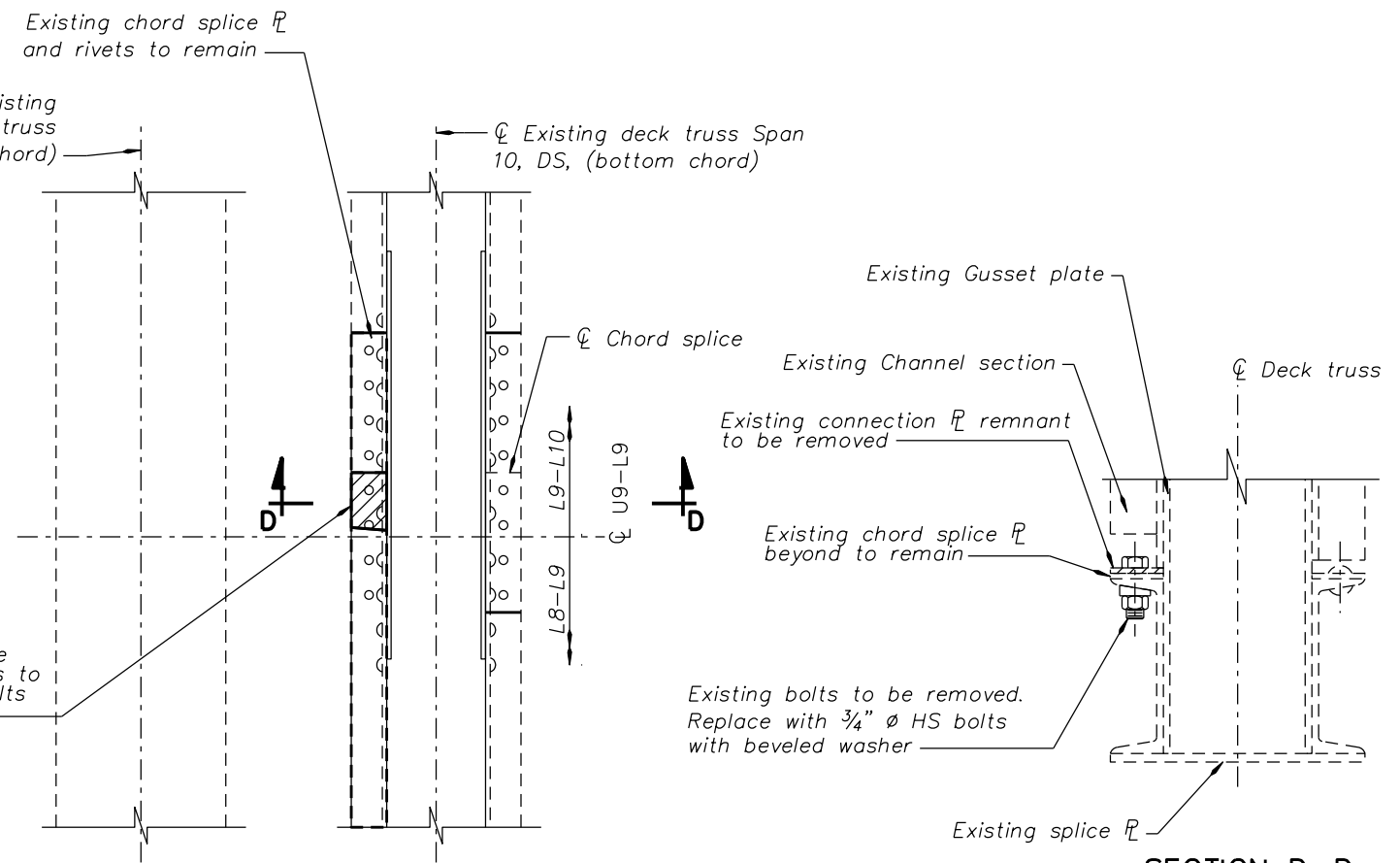

**REPAIR DETAIL 5 – TRUSS CHORD REPAIR**  
Scale: NTS

REPAIR LOCATIONS				
SPAN	TRUSS	LOCATION	REPAIR DETAIL NO.	NOTES
3	DOWNSTREAM	FB3	4	KNEE BRACE
3	DOWNSTREAM	FB11	4	KNEE BRACE
10	DOWNSTREAM	PP-L9	5	LOOSE BOLTS

Δ	DATE	REVISION	BY

ACCOMPANIED BY DWGS.

DRAFTER: **E. Gahan**  
 DESIGNER: **M. Libby**  
 CHECKER: **S. Timilsina**  
 REVIEWER: **M. Mitchell**



STRUCTURE NO.  
06645  
 DATE  
March 2023  
 CALC. BOOK

**HOOD RIVER INTERSTATE BRIDGE  
 MISCELLANEOUS TRUSS REPAIRS  
 HOOD RIVER-WHITE SALMON HIGHWAY  
 HOOD RIVER, OR & KLICKITAT, WA COUNTIES**  
**FLOORBEAM & CHORD SPLICE REPAIRS**

SHEET  
4  
OF  
7  
 DRAWING NO.  
110212

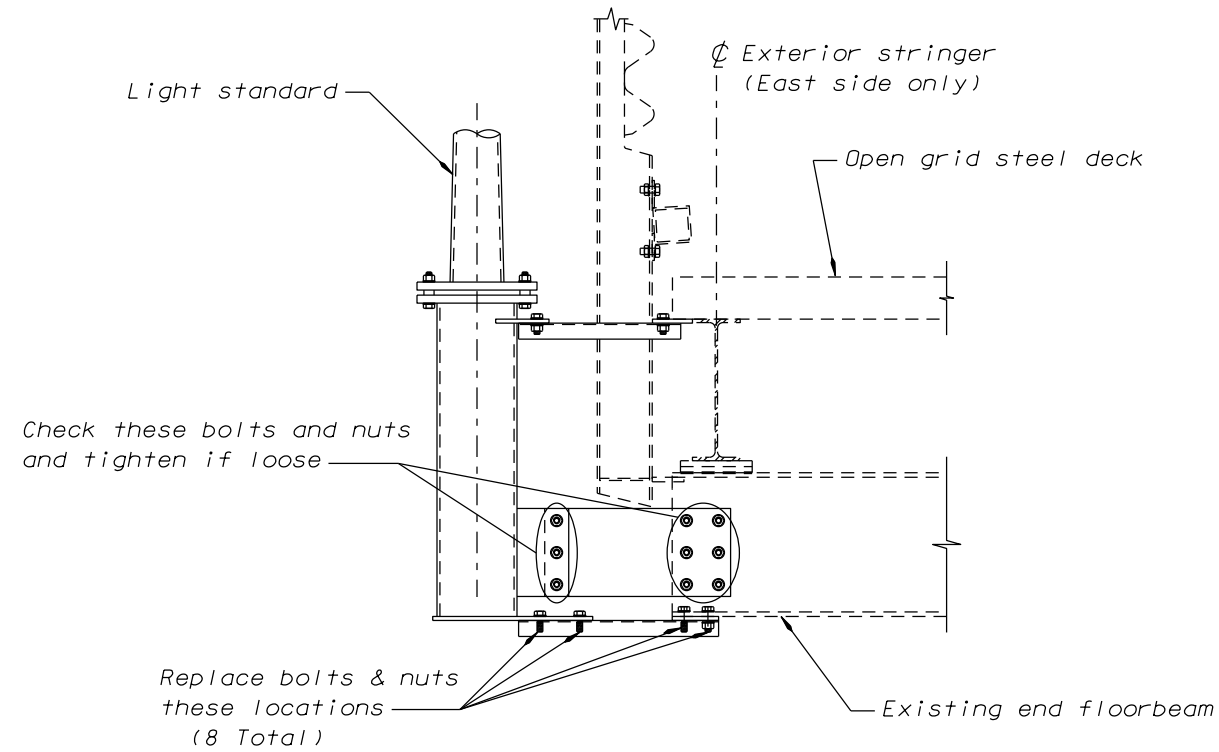

**PIER 4 LIGHT POLE REPAIR**

Scale: 1" = 1'-0"

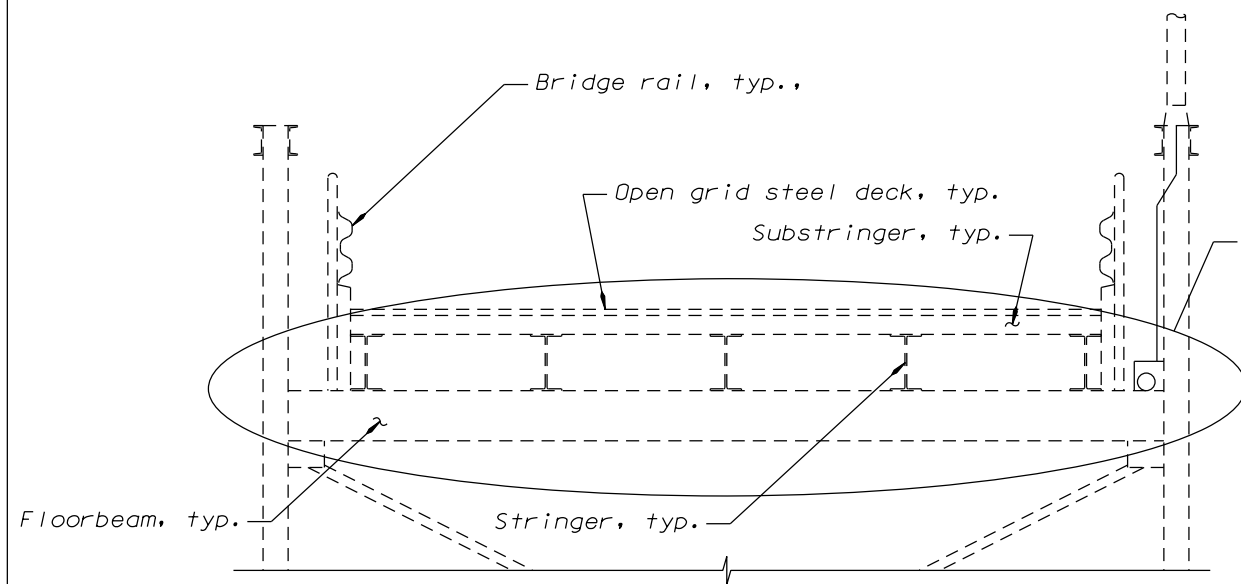

**TYPICAL SECTION - SPAN 1**

Scale: 3/8" = 1'-0"

Remove deposited material from stringers, floorbeams and truss top chord members in Span 17 to 19.  
Remove deposited material from stringers and floorbeams from FBO to FB9

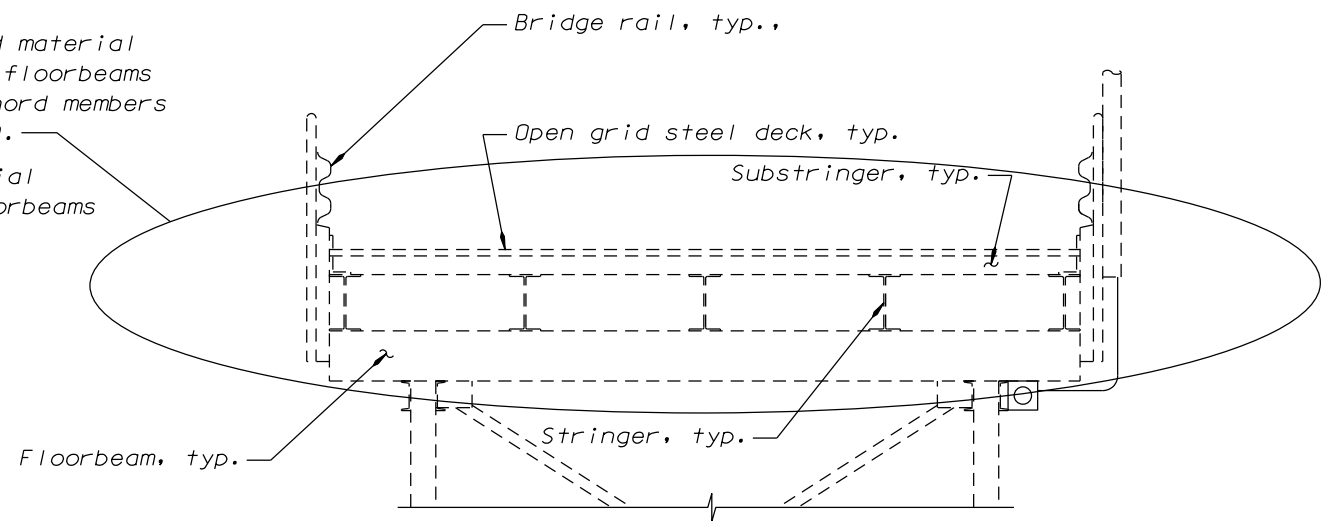

**TYPICAL SECTION - SPANS 17 - 19**

Scale: 3/8" = 1'-0"

Δ	DATE	REVISION	BY

DRAFTER: *E. Gahan*  
 DESIGNER: *M. Libby*  
 CHECKER: *S. Timilsina*  
 REVIEWER: *M. Mitchell*

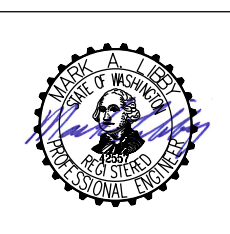

STRUCTURE NO.  
06645  
DATE  
March 2023  
CALC. BOOK

**HOOD RIVER INTERSTATE BRIDGE  
 MISCELLANEOUS TRUSS REPAIRS  
 HOOD RIVER-WHITE SALMON HIGHWAY  
 HOOD RIVER, OR & KLICKITAT, WA COUNTIES**

**LIGHT POLE & DEBRIS REMOVAL DETAILS**

SHEET  
5  
OF  
7  
DRAWING NO.  
110213

ACCOMPANIED BY DWGS.

REPAIR LOCATIONS			
SPAN	PIER	US/DS	REPAIR DETAIL
3	3	US & DS	6
14	15	US	6
15	16	US & DS	6

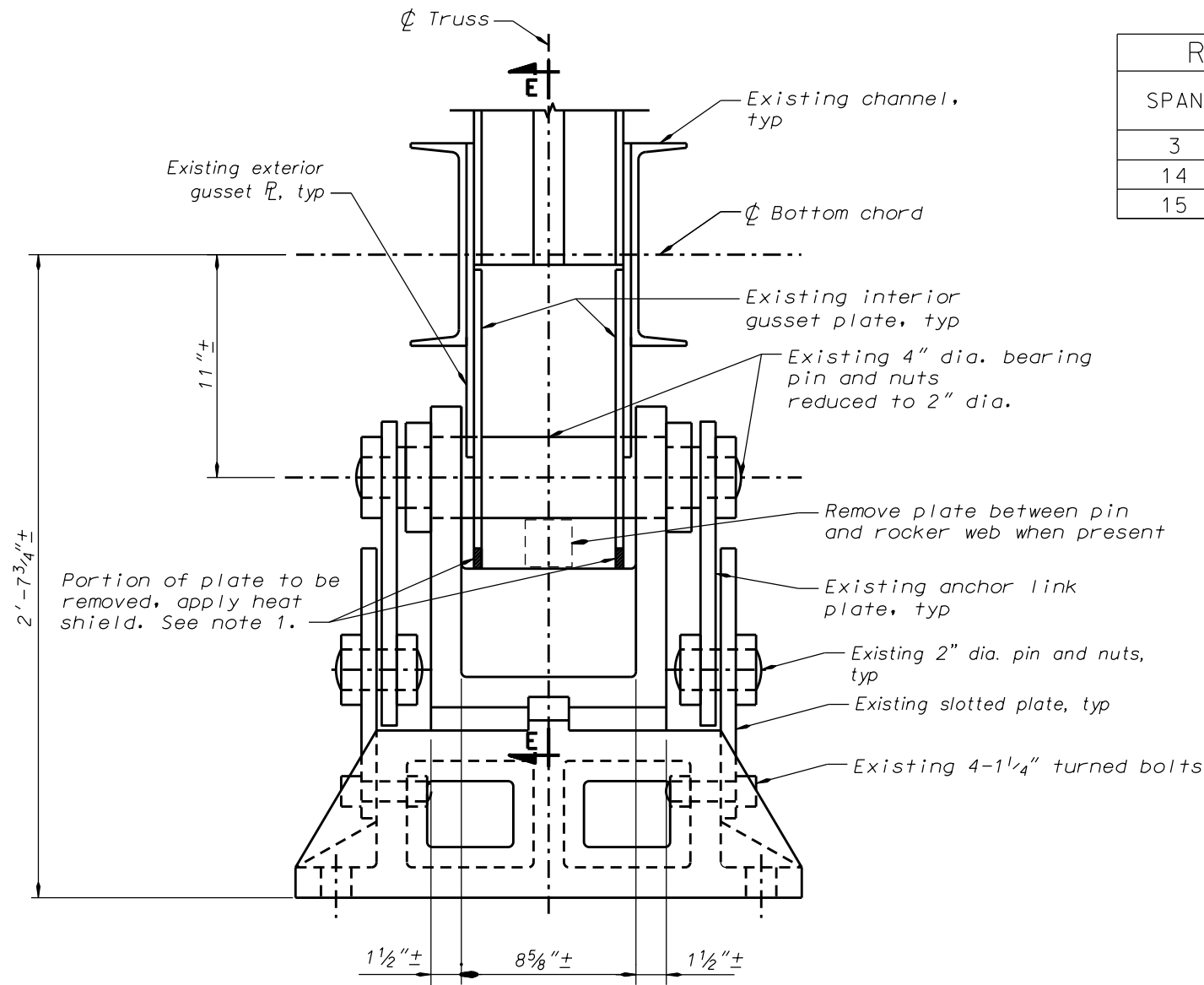

REPAIR DETAIL 6 - ROCKER BEARING MODIFICATION  
Scale: 1 1/2" = 1'-0"

Construction Notes for Rocker Bearings:

1. Protect steel rocker plate, web plate, and bearing pin in place. Provide heat shield between interior gusset plate and cast rocker bearing during cutting.
2. Torch cut portion of interior gusset plate, as indicated, to clear rocker web plate.
3. Apply prime, intermediate and top coat to areas with removed or damaged paint.

Construction Notes for Joint Header Repairs:

1. Remove the broken piece of expansion joint header (steel angle), approximately 7 inches long in the southbound lane.
2. Sawcut, chip, and remove loose concrete beneath header segment.
3. Provide 1/2" minimum thickness of grout patching beneath header angle.
4. Patch deck concrete with rapid setting non-shrink grout with a minimum 28-day strength of 5000 psi.
5. Reinstall steel angle header segment before grout sets and tack weld in place on both legs. After grout is set, weld joints full length.

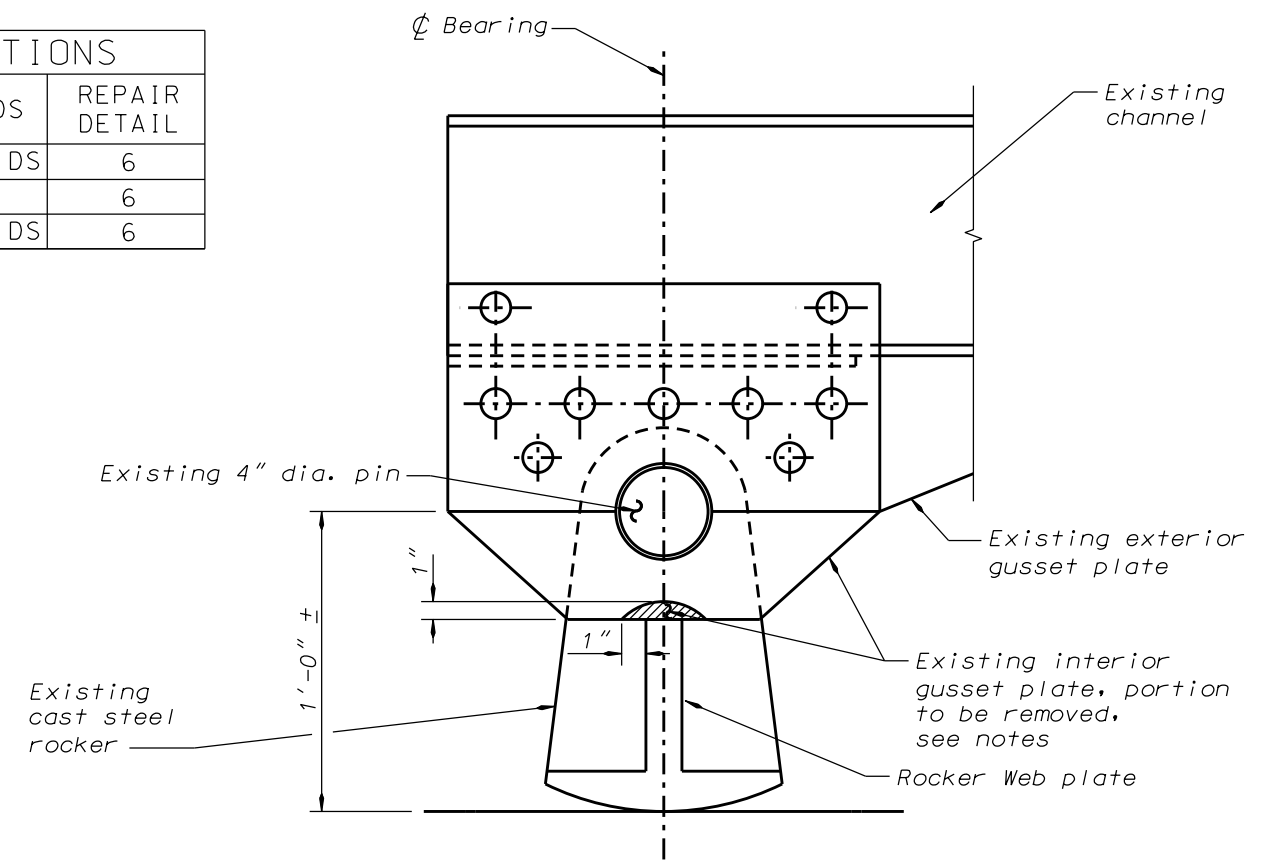

SECTION E-E  
Scale: 1 1/2" = 1'-0"

Indicates portion to be removed

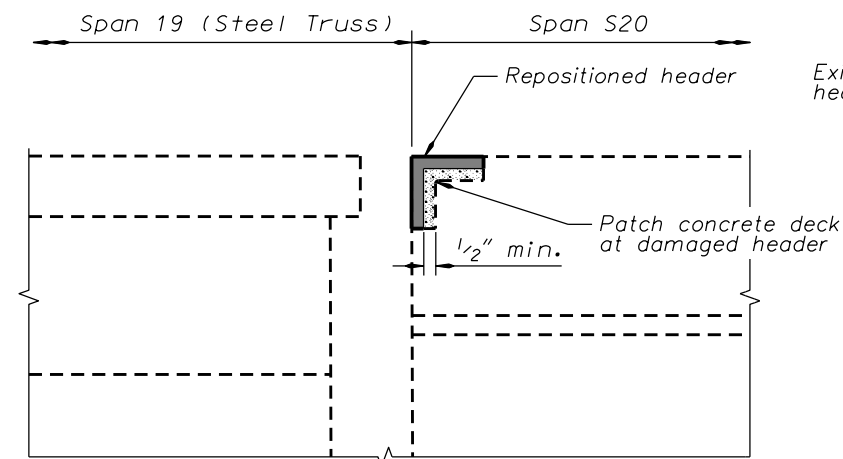

SECTION F-F  
Scale: 1 1/2" = 1'-0"

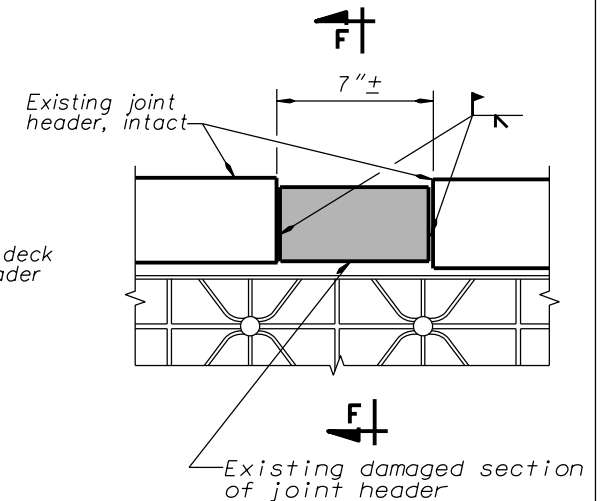

JOINT HEADER REPAIR  
Scale: 1 1/2" = 1'-0"

DATE	REVISION	BY

ACCOMPANIED BY DWGS.

DRAFTER: E. Gahan  
DESIGNER: M. Libby  
CHECKER: S. Timilsina  
REVIEWER: M. Mitchell



STRUCTURE NO.  
06645  
DATE  
March 2023  
CALC. BOOK

HOOD RIVER INTERSTATE BRIDGE  
MISCELLANEOUS TRUSS REPAIRS  
HOOD RIVER-WHITE SALMON HIGHWAY  
HOOD RIVER, OR & KLICKITAT, WA COUNTIES  
ROCKER BEARING & JOINT HEADER REPAIRS

SHEET  
6  
OF  
7  
DRAWING NO.  
110214

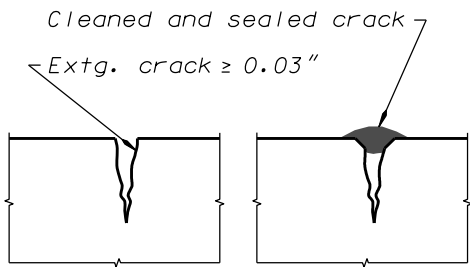
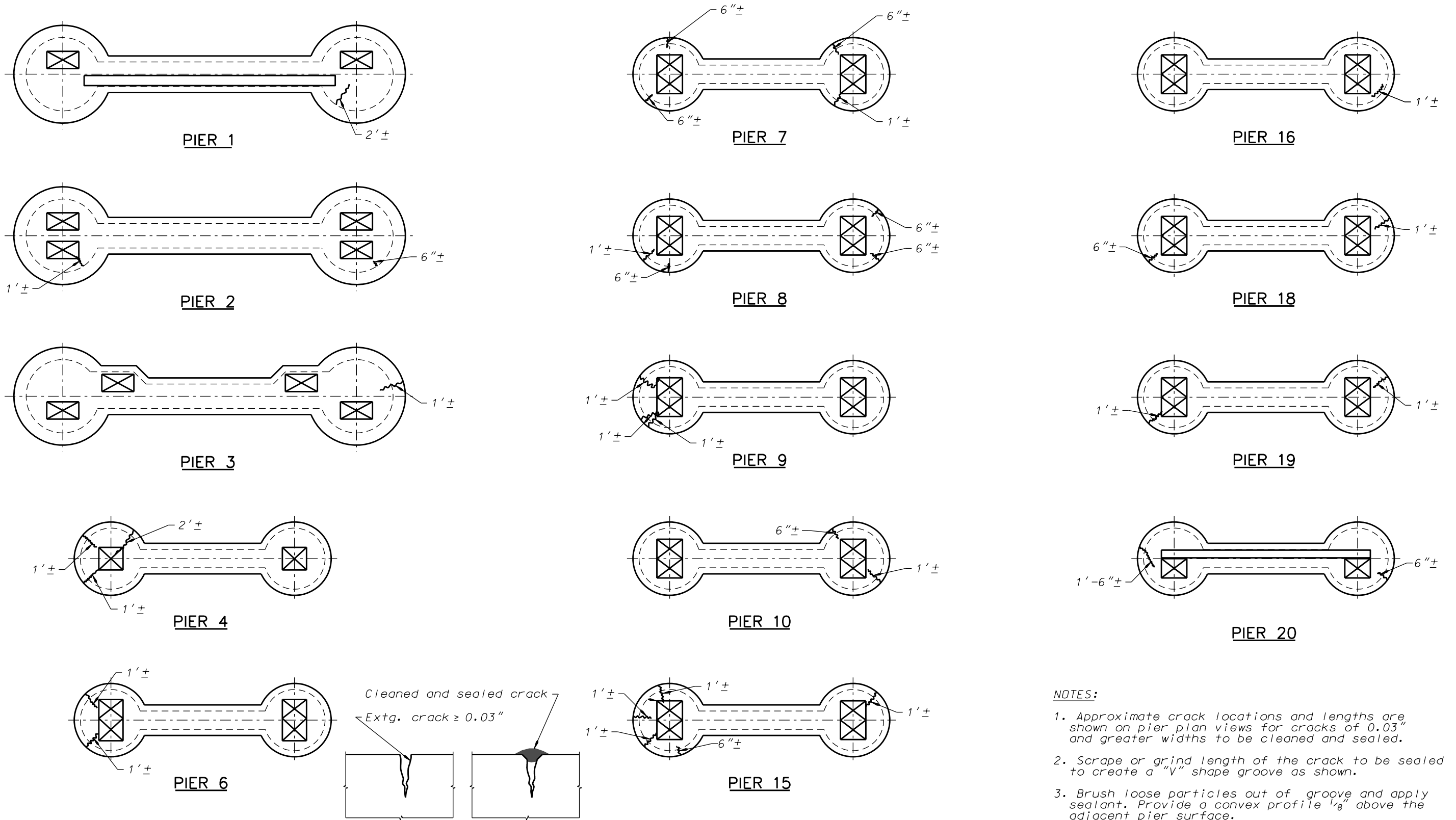

**CRACK SEAL DETAILS**

Scale: NTS

**NOTES:**

1. Approximate crack locations and lengths are shown on pier plan views for cracks of 0.03" and greater widths to be cleaned and sealed.
2. Scrape or grind length of the crack to be sealed to create a "V" shape groove as shown.
3. Brush loose particles out of groove and apply sealant. Provide a convex profile 1/8" above the adjacent pier surface.

	DATE	REVISION	BY	DRAFTER: E. Gahan DESIGNER: M. Libby CHECKER: S. Timilsina REVIEWER: M. Mitchell					STRUCTURE NO. 06645	HOOD RIVER INTERSTATE BRIDGE MISCELLANEOUS TRUSS REPAIRS HOOD RIVER-WHITE SALMON HIGHWAY HOOD RIVER, OR & KLICKITAT, WA COUNTIES	SHEET 7 OF 7
	ACCOMPANIED BY DWGS.								RENEWS: 12-31-2024		DATE March 2023
					CALC. BOOK	PIER CRACK SEALING DETAILS	110215				

This page intentionally left blank.

# Commission Memo

Prepared by: Kevin Greenwood  
Date: April 18, 2023  
Re: Resolution Commencing Public Process  
for Bridge Replacement Activities



---

Based upon the discussion item on the agenda related to commencing the public process for funding the Hood River White Salmon Bridge Authority Activities, the attached Resolution incorporates many recitals summarizing the process that has gone into the bridge replacement effort thus far. The Resolution authorizes staff to take the immediate next steps to develop, in collaboration with HNTB, JLA, and the Bistate Working Group members, a robust public outreach process related to implementing a toll increase to fund Hood River White Salmon Bridge Authority activities.

**RECOMMENDATION:** Approve Resolutions No. 2022-23-13 Commencing Public Process for Funding Hood River White Salmon Bridge Authority Activities.

This page intentionally left blank.



**PORT OF HOOD RIVER**  
**Resolution No. 2023-24-13**

**A RESOLUTION COMMENCING PUBLIC PROCESS FOR FUNDING  
HOOD RIVER WHITE SALMON BRIDGE AUTHORITY ACTIVITIES**

**WHEREAS**, the Hood River White Salmon Interstate Bridge ("Bridge") is a critical transportation facility in the Mid-Columbia Region, and the Port of Hood River ("Port") must manage, maintain, inspect, and operate the Bridge in a safe manner for the long-term use of residents, visitors, and businesses; AND

**WHEREAS**, the Bridge is beyond its design life, is functionally obsolete and insufficient for modern vehicle and marine freight configurations, and must be replaced as soon as possible; AND

**WHEREAS**, in January of 2021, the Port of Hood River and its partners the City of Hood River, Hood River County, City of Bingen, City of White Salmon, and Klickitat County formed the Bistate Working Group ("Working Group"), as a policy advisory committee to the Port Commission for all matters related to bridge replacement; AND

**WHEREAS**, the 81<sup>st</sup> State of Oregon Legislative Assembly during their 2022 Regular Session passed House Bill 4089 establishing statutory framework for local governments in Oregon and Washington to enter into a commission formation agreement to create a bistate governance commission to oversee construction, maintenance, repair, operation, renewal, financing and refinancing of new interstate toll bridge across the Columbia River; AND

**WHEREAS**, the 67<sup>th</sup> State of Washington Legislature during their 2022 Regular Session passed Substitute Senate Bill 5558, an Act relating to the bistate governance of interstate toll bridges owned by local governments; amending RCW 47.56.860; and adding a new chapter to Title 47 RCW that authorizes local governments to enter into a commission formation agreement to form and charter a commission for the independent bistate governmental authority with sufficient powers to efficiently and equitably develop, operate, maintain, toll, and finance the replacement bridge; AND

**WHEREAS**, at their February 21, 2023 Regular Session, the Port approved signing the Hood River White Salmon Bridge Authority Commission Formation Agreement; AND

**WHEREAS**, the Hood River White Salmon Bridge Authority ("Bridge Authority") is expected to begin operations on July 1, 2023; AND

**WHEREAS**, the Port is committed to ensuring the Bridge Authority can perform all activities needed for the successful completion of the project by its stated goal of October 2029; AND

**WHEREAS**, on February 6, 2023, the Working Group received the reported results of the Washington State Transportation Commission Traffic & Revenue Study that provided two scenarios to provide the necessary toll revenues for the Bridge Authority activities, including for the purpose of capitalizing reserves for federal toll bonds; AND

**WHEREAS**, the Working Group anticipates the project will need to raise \$70 - \$150 million in locally sourced funding to complete the project funding package; AND

**WHEREAS**, on April 3, 2023, the Working Group recommended the Port implement a toll increase rate schedule and timeline that would provide the adequate funding for the Bridge Authority activities; AND

**WHEREAS**, on April 4, 2023, the Port approved Resolution 2022-23-11 establishing a toll revenue use policy that would dedicate all toll revenues to only those costs associated with bridge operations, maintenance, repair, and replacement only by June 30, 2028; AND

**WHEREAS**, the Port seeks to implement the toll increase dedicated to the Hood River White Salmon Bridge Authority effective September 1, 2023; AND

**WHEREAS**, the incremental toll revenue from the 2023 toll increase will be placed in a separate fund to be used only for the payment of any expenditures associated with the Hood River-White Salmon Replacement Bridge; AND

**WHEREAS**, the Port and the Working Group agree that a public process is necessary to move forward with approval and implementation of the toll increase to provide adequate opportunity for public input and delivery of public information; NOW, THEREFORE

THE PORT OF HOOD RIVER BOARD OF COMMISSIONERS RESOLVES AS FOLLOWS:

The Port of Hood River staff and contract consultants from HNTB and JLA, in collaboration with the public officials currently serving on the Bistate Working Group, and in partnership with the Hood River White Salmon Bridge Authority upon its establishment, will immediately commence development and deployment of a public input process focused on providing funding for the Hood River White Salmon Bridge Authority activities and the toll increase rates, rules, and timeline for implementation.

Adopted by the Board of Commissioners of the Port of Hood River this 18th day of April, 2023.

**SIGNED**

\_\_\_\_\_  
Ben Sheppard, President

**ATTEST**

\_\_\_\_\_  
Michael Fox, Secretary

This page intentionally left blank.

# Commission Memo



Prepared by: John Mann  
Date: April 18, 2023  
Re: Underwater Concrete Pier Repair Project

---

Underwater pier analysis was performed on the Bridge by HDR beginning in July 2022. Pockets of concrete spalling were found on piers 6 and 8 that require repair. These pockets have also shown up in underwater inspections performed by ODOT in years past. HDR worked with port staff to prepare bid documents for this work. For the health of our bridge these locations should be repaired regardless of the new bridge installation. Engineers estimate for the project was \$300,000.00.

Bids were opened March 30, 2023, with a range of \$465,000- \$574,000. The lowest bid was submitted by Advanced American at \$465,000.00. The Port has a good working relationship with Advanced American which is reflected in their bid price.

**RECOMMENDATION:** Authorize Award of Contract to Advanced American for the Underwater Pier Repairs Project in an Amount Not to Exceed \$465,000.00 and authorize the Executive Director to sign the contract at the conclusion of the protest period, barring no protests.

**PORT OF HOOD RIVER  
PUBLIC IMPROVEMENT CONTRACT**

This Public Improvement Contract ("Contract") entered into between the PORT OF HOOD RIVER, an Oregon municipal corporation, ("PORT") and Advanced American Construction, an Oregon corporation ("CONTRACTOR"), for completion of the Hood River Interstate Underwater Pier Repairs Project ("Project"). PORT and CONTRACTOR may be referred to herein individually as a "Party" or collectively as the "Parties."

**WITNESSETH:**

**WHEREAS**, PORT issued a Bid Solicitation for the Project on March 9, 2023, inviting bids to repair concrete piers on the Hood River-White Salmon Interstate Bridge ("Bridge"). The Project includes the procurement of materials and repairs required in the bid documents attached for the repair of the concrete piers.

**WHEREAS**, CONTRACTOR submitted a bid in response to Port's Bid Solicitation, offering to perform the Work under the terms and conditions of this Contract;

**WHEREAS**, PORT evaluated all offers and selected CONTRACTOR to perform the Work; and,

**WHEREAS**, the Parties hereto desire that this Contract be undertaken and completed on the terms and conditions as hereafter set forth;

**THEREFORE, IT IS AGREED AS FOLLOWS:**

**I. TERMS OF PERFORMANCE**

CONTRACTOR agrees to perform the Work and provide all machinery, tools, apparatus, materials, equipment, labor and other means of construction necessary to complete the Work in accordance with all terms specified in (i) this Contract; (ii) the Underwater Repairs Project on the Hood River – White Salmon Interstate Bridge Solicitation ("Solicitation"), including the Port of Hood River General Conditions for Public Works Contracts ("General Conditions") incorporated therein; and (iii) CONTRACTOR's submission to Solicitation ("CONTRACTOR's Submission"). This Contract, Solicitation, General Conditions, and CONTRACTOR's Submission are collectively referred to herein as the "Contract Documents." The Contract Documents are incorporated by reference and constitute the entire agreement between PORT and CONTRACTOR.

In the event of a conflict between the Contract Documents, the controlling document shall be this Contract, then the General Conditions, then the Solicitation, and finally CONTRACTOR's Submission. In the event and to the extent any provisions contained in multiple documents address the same or substantially the same subject matter but do not actually conflict, the more recent provisions shall be deemed to have superseded earlier provisions.

**II. COMPENSATION**

Subject to the provisions of the Contract Documents and in consideration of CONTRACTOR's faithful performance of the terms and conditions thereof by the CONTRACTOR and CONTRACTOR's completion of the Work, PORT agrees to pay CONTRACTOR in the manner provided in the Contract Documents. Compensation is for completion of the Work pursuant to the Contract Documents.

**III. CONTRACT DATES**

- 1) Project Start Date: Ten (10) calendar days from issuance of Notice to Proceed
- 2) Physical Working Days Final completion July 15, 2023
- 3) Substantial Completion: Substantial completion of June 30, 2023
- 4) Final Completion: Final completion July 15, 2023

**IV. LIQUIDATED DAMAGES**

- 1) Reasonable evidence that the Work will not be completed within the Contract Time required by the
- 2) Contract, and that the unpaid balance would not be adequate to cover actual or liquidated damages for the anticipated delay;
- 3) Failure to carry out the Work in accordance with the Contract Documents; or
- 4) Assessment of liquidated damages, when withholding is made for offset purposes.

Permitting CONTRACTOR to continue and finish the Work, or any part thereof, after the Physical Working Days period, or Alternate Physical Working Days period, as pertinent, has expired shall in no way operate as a waiver on the part of PORT or any of its rights under the Contract.

Payment of liquidated damages shall not release CONTRACTOR from obligations in respect to the fulfillment of the entire Contract, nor shall the payment of such liquidated damages constitute a waiver of PORT's right to collect any additional damages which may be sustained by failure of the CONTRACTOR to carry out the terms of the Contract, it being the intent of the Parties that said liquidated damages be full and complete payment only for failure of CONTRACTOR to complete the Work on time.

**5) REPRESENTATIVES**

PORT designates Kevin M. Greenwood, its Executive Director as its Authorized Representative in the administration of this Contract. Kevin Greenwood's contact phone is (541) 386-1138 and email is [kgreenwood@portofhoodriver.com](mailto:kgreenwood@portofhoodriver.com). CONTRACTOR designates \_\_\_\_\_, its title \_\_\_\_\_, as its Authorized Representative to act on its behalf. [CONTRACTOR's Authorized Representative's contact phone is \_\_\_\_\_ and email is \_\_\_\_\_]. Either Party shall be entitled to remove and/or substitute their respective Authorized Representative by providing written notice to the other Party.

**6) ACCEPTED MODIFICATION TO SOLICITATION SECTION G/INSURANCE**

Pursuant to Section VI hereinabove, the Parties agree, and the PORT hereby approves CONTRACTOR's request to have CONTRACTOR's General Commercial Liability deductible limit of \$50,000 as set forth in the second to last paragraph of the Solicitation section G, Insurance provision, increased to \$100,000. Except as modified by this Section VII, all terms and conditions of the Contract Documents shall remain in full force and effect.

Notwithstanding the foregoing, the below-named individuals shall be the designated points of contact for matters relating to performance, payment, authorization, and to carry out the responsibilities of the Parties. Any notice, request, report, or other communication required or permitted hereunder shall be in writing and shall be delivered personally (by courier or otherwise), by electronic mail, sent by certified or registered mail, postage prepaid and return receipt requested, or by express mail or other nationally recognized overnight or same-day delivery service. Any such notice shall be deemed given when so delivered by electronic mail, by such delivery service, or by the United States mail to each Party's Authorized Representative and to the following individuals:

**If to PORT:**

Attn: John Mann, Facilities Director  
1000 E. Port Marina Drive  
Hood River, OR 97031  
Email: [jmann@portofhoodriver.com](mailto:jmann@portofhoodriver.com)  
Phone: (541) 399-9228

**If to CONTRACTOR**

Attn: [ \_\_\_\_\_ ]  
[ \_\_\_\_\_ ]  
[ \_\_\_\_\_ ]  
Email: [ \_\_\_\_\_ ]  
Phone: [ \_\_\_\_\_ ]

**I. INTEGRATION**

The Contract Documents constitute the entire agreement between the Parties. No modification or change of terms of this Contract shall bind either Party unless in writing and signed by the Authorized Representatives of both Parties. Such waiver, consent, modification or change, if made, shall be effective only in the specific instance and

for the specific purpose given. There are no other understandings, agreements, or representations, oral or written, not specified herein regarding this Contract. CONTRACTOR, by the signature below of its Authorized Representative, hereby acknowledges that it has read this Contract, understands it, and agrees to be bound by its terms and conditions.

**II. COUNTERPARTS, EXECUTION, ELECTRONIC SIGNATURES**

This Contract may be executed in counterparts. This Contract may be executed using original signatures, facsimile signatures, or only with PORT's prior approval, Electronic Signatures as defined in the Electronic Signatures in Global and National Commerce Act, that can be authenticated. Under ORS 84.014, CONTRACTOR's consent is not required for this Contract to be executed using Electronic Signatures. Even if ORS 84.014 is determined to be inapplicable or invalid, CONTRACTOR grants such consent.

IN WITNESS WHEREOF the Parties have executed this Contract on \_\_\_\_\_.

**CONTRACTOR**  
**ADVANCED AMERICAN CONSTRUCTION**

**PORT OF HOOD RIVER**

By \_\_\_\_\_  
[Name]  
Its \_\_\_\_\_  
[Title]

By \_\_\_\_\_  
Kevin M. Greenwood  
Its Executive Director



# Port of Hood River Underwater Pier Repair

Issued: March 9, 2023

## **PORT OF HOOD RIVER**

1000 E. PORT MARINA DRIVE  
Hood River, Oregon 97031  
John Mann  
FACILITIES DIRECTOR

**Consultant:** **HDR Engineering, Inc.**  
Mark Libby, PE  
1050 SW 6<sup>th</sup> Ave., Suite 1800  
Portland, OR 97204  
Telephone: 503-423-3757  
Email: mark.libby@hdrinc.com

**Owner:** **PORT OF HOOD RIVER**  
1000 E. Port Marina Drive  
Hood River, Oregon 97031  
Telephone: (541) 386-1645  
Fax: (541) 386-1395  
porthr@gorge.net  
www.portofhoodriver.com

# **Underwater Pier Repair**

## **Bid Solicitation**

### **Table of Contents**

PART 1	Schedule	Page 4
PART 2	Invitation to Bid	Page 6
PART 3	Instructions to Bid (ITB)	Page 8
PART 4	Bid Form Bid Sheet Contractor Registration Form First Tier Subcontractor Disclosure Form	Page 16
PART 5	Bid Bond Form	Page 23
PART 6	Performance and Payment Bond	Page 25
PART 7	Certificate of Insurance Form	Page 30
PART 8	General Conditions (A-L)	Page 32
PART 9	Technical Specifications	Page 62
PART 10	Construction Plans (Bound separately and incorporated by reference)	Page 66
PART 11	Port of Hood River Public Improvement Contract (sample)	Page 68

**PART 1**  
**SCHEDULE**

## SCHEDULE

<b>Invitation to Bid Advertised</b>	March 9, 2023
<b>Bids Due</b>	March 30, 2023, 2 P.M. PDT
<b>Bid Opening</b>	March 30, 2023, 2 P.M. PDT
<b>First-Tier Subcontractor Disclosure Form Due</b>	March 30, 2023, 4 P.M. PDT
<b>Contractor Experience Reference Projects</b>	March 30, 2023, 4 P.M. PDT
<b>Notice of Intent to Award Issued</b>	April 6, 2023
<b>Protest Deadline</b>	April 13, 2023
<b>Award of Contract</b>	April 20, 2023
<b>Required Documents Due from Awarded Contractor (Including bonding and insurance)</b>	April 20, 2023
<b>Substantial Completion</b>	June 30, 2023
<b>Final Completion</b>	July 15, 2023

**PART 2**  
**INVITATION TO BID**

## **Invitation to Bid Underwater Pier Repair**

The Port of Hood River is requesting bids for Underwater Pier Repair for the Hood River-White Salmon Interstate Bridge at Hood River, Oregon 97031. This work includes underwater concrete patching repairs to Piers 6 and 8. This is a Prevailing Wage project subject to ORS 279C.800 to 279C.870.

Beginning Thursday, March 9, 2023 at 2:00 P.M. PDT a complete solicitation document, including scope of work, sample contract, and design specifications, will be posted to the Port of Hood River's projects on the Oregon Buys website at: <https://oregonbuys.gov/bsol/>. Hard copies may be examined or purchased during normal business hours at:

Port of Hood River  
1000 E. Port Marina Drive  
Hood River, Oregon 97031

There will be a \$40 nonrefundable charge for each printed copy of the solicitation document. The document can also be viewed or printed online at <https://oregonbuys.gov/bsol/>. Any subsequent addenda, clarifications, or project documents will be posted to the Oregon Buys website.

There is no mandatory pre-bid meeting for this project.

Bidders are not required to be pre-qualified under ORS 279C.430.

Bids must be submitted in hard copy only and must be addressed to John Mann, Facilities Director, Port of Hood River. Bids must be received at the Port office located at 1000 E. Port Marina Drive, Hood River OR 97031. by **2:00 P.M. PDT on Thursday, March 30, 2023**. Bids will not be accepted after 2:00 P.M. PDT on Thursday, March 30, 2023. Bids will be publicly opened in the Port office immediately following the bid deadline.

**PART 3**  
**INSTRUCTIONS TO BID**

## **INSTRUCTIONS TO BID**

**OWNER:** Port of Hood River, 1000 E. Port Marina Drive, Hood River, OR 97031, Telephone (541) 386-1645, Fax (541) 386-1395, Email porthr@gorge.net, Website www.portofhoodriver.com.

This Invitation to Bid and the resulting Contract are governed by Oregon Law. Specific laws and rules that govern the solicitation process are found in Chapters 279A and 279C of the Oregon Revised Statutes (ORS), and Chapter 137, Divisions 046 and 049 of the Administrative Rules of the Oregon Department of Justice (OAR). Bidders should obtain and become acquainted with the applicable provisions of the above laws and rules.

### **DESCRIPTION**

Bids are requested to perform underwater concrete patching repairs to Piers 6 and 8 of the Hood River-White Salmon Interstate Bridge. This is a Prevailing Wage Project subject to ORS 279C.800 to 279C.870. Project scope of work, plans and specifications are included in this Contract Solicitation document or attached by reference.

The work contemplated under this Contract includes all labor, tools, machinery, materials, transportation, equipment and services necessary for, and reasonably incidental to, the completion of all work in connection with the project described in the Contract, the General Conditions, all applicable special conditions, plans, specifications, and addenda.

All questions regarding the project should be directed via email (not phone) to **John Mann at jmann@portofhoodriver.com**. Questions and answers will be posted on the project page on the Oregon Buys website. Contractor names will not be included.

### **INVITATION TO BID DOCUMENT AVAILABILITY**

A complete solicitation document may be examined or obtained (\$35.00) during normal working hours at the Port office, 1000 E. Port Marina Drive, Hood River, Oregon after 2:00 P.M. PDT on Thursday, March 9, 2023 or by calling the Port Office (541)386-1645. Plans will be available to download at the Port of Hood River project page on the Oregon Buys website at <https://oregonbuys.gov/bsol/>.

### **SOLICITATION LAW AND RULES**

This ITB and resulting Contract are governed by Oregon Law. Specific laws and rules that govern the solicitation process are found in Chapters 279A and 279C of the Oregon Revised Statutes, and Chapter 137, Divisions 046 and 049 of the Administrative Rules of the Oregon Department of Justice (Model Public Contracting Rules). The ITB and resulting Contract may be subject to other laws and rules. Offerors should obtain and become acquainted with the applicable provisions of the above laws and rules.

### **BRAND NAME USAGE:**

Any brand name listed in the specifications without an "or approved equal" shall establish the minimum requirements for quality, utility, durability, function and purpose. Other brand names may be used in the construction of the product as long as they are equal to or better than the product brand named, and the brand name listed is not mandated pursuant to a brand name exemption.

Any brand name listed in the specifications with an "or approved equal" shall establish the minimum requirements for quality, utility, durability, function and purpose. Other brand names may be used in the construction of the project as long as they are equal to or better than the product brand named, and the proposed product has been approved in writing by the Owner's Authorized Representative prior to installation, and the brand named is not mandated pursuant to a brand name exemption.

The Owner's Representative shall determine, in its sole discretion, whether a product is "or approved equal."



Any brand name listed in the specifications with an "or approved equal" or an "or approved equivalent" shall establish the minimum requirements for quality, utility, durability, function and purpose. Other brand names may be used in the construction of the project as long as they are equal to or better than the product brand named, and the proposed product has been approved in writing during the bidding process detailed in the following section and the brand named is not mandated pursuant to a brand name exemption.

**SOLICITATION PROTEST; REQUEST FOR CHANGE; REQUEST FOR CLARIFICATION; REQUEST FOR BRAND NAME/PRODUCT SUBSTITUTION**

If a Bidder finds discrepancies in, or omissions from the plans, specifications or Contract documents, or has doubt as to their meaning, the Bidder shall at once notify the Owner. The Owner will then investigate and determine if an Addendum will be issued.

Bidders may, in writing, request brand approval, requests for substitutions, requests for clarifications, requests for change, Bid protest. The Owner must receive this written protest or request no later than five (5) calendar days prior to the Bid Closing date. The written protest or request shall include the reasons for the protest or request, and any proposed changes to the Bid specifications or contract terms. Envelopes containing Bid protests shall be marked as follows: "Contract Provision Request for Change" or "Contract Provision Protest", and Solicitation Document Identification Project Title.

Clarifications, whether verbal, in writing, or included in an Addendum or Addenda as a "clarification," do not change Plans, Specifications, contractual terms, or procurement requirements of an ITB. If a request for clarification raises an issue that the Owner determines should be handled by formally amending the ITB, the Owner will do so only by announcing such a change in an Addendum or Addenda, not through information identified as a "clarification."

The Owner will promptly respond to each properly submitted written request for brand approval, request for substitution, request for change, and protest. Where appropriate, the Owner will issue ITB revisions via Addenda made by fax or email and will posted on the Owner's website. A Bidder shall provide written acknowledgement of receipt of all issued Addenda with its Bid.

INFORMAL RESPONSES DO NOT AFFECT THE PROVISIONS OF THE ITB. PROVISIONS OF THE ITB CAN ONLY BE CHANGED VIA ADDENDA ISSUED BY THE OWNER.

Pursuant to OAR 137-049-0250, no protest against award because of the content of bid specifications or contract terms shall be considered after the deadline established above for submitting protests of bid specifications or contract terms.

**EXAMINATION OF THE CONTRACT DOCUMENTS AND WORK SITE**

Bidders should carefully examine the bid and contract documents and familiarize themselves with the work site to fully acquaint themselves with all the conditions and matters which can in any way affect the work or the cost thereof.

Each bidder shall thoroughly examine and be familiar with legal and procedural documents, general conditions, specifications, drawings, plans, addenda (if any), and all other Contract Documents. The submission of a bid shall constitute an acknowledgment upon which the Port may rely, that the bidder is experienced in the uses and interpretation of plans and specifications such as those included in the Contract Documents and has thoroughly examined and is familiar with the Contract Documents.

The failure or neglect of a bidder to receive or examine any of the Contract Documents, perform site investigations and/or other investigations or examinations shall in no way relieve the bidder from any obligations with respect to the bid or the contract. No claim for additional compensation will be allowed which is based upon a lack of knowledge of any Contract Documents or existing site conditions.

**BID FORMAT**

**Sealed Bids** must be received in the Port office, 1000 E. Port Marina Drive, or by mail to 1000 E. Port Marina Drive, Hood River, OR 97031 on or before 2 P.M. PDT on Thursday, March 30, 2023.

All Bids must be sealed and received prior to the bid closing time and date. All Bids shall be prepared on hard copy, but must be signed in ink by an authorized representative of the Bidder. Email or facsimile Bids will not be accepted.

Required Information shall be submitted on the forms specific in the ITB.

The following forms and schedules shall be completed, signed and included in the bidder package and shall be submitted prior to the Bid Deadline:

- Bid Form
- Bid Sheet
- Contractor Registration Form
- Bid Bond Form

The following shall be submitted within two (2) working hours after Closing.

- First Tier Subcontractor Disclosure Form
- Contractor Experience Reference Projects per Section 1.03 of Special Provision

Alteration and erasures made before Bid submission must EACH be INDIVIDUALLY initialed in ink by the person signing the Bid. Bids, once submitted, may be modified in writing before closing. Modifications made after Offer submissions shall be prepared on Bidder’s letterhead, be signed by an authorized representative, and state that the modifications amend and supersede the prior bid. Failure to comply with the provisions of this paragraph shall result in Bid rejection. Nothing in this paragraph shall be construed as allowing the Bidder to alter or otherwise change the form of the proposal, the form of the Contract, the conditions of the Bid, the specifications, and/or plans attached to the Bid documents.

Modifications must be submitted in a sealed envelope marked as follows:

Underwater Pier Repair Bid  
Closing Date  
Bidder Legal Name  
Oregon CCB #

Bidders may not modify bid after closing.

**BID SUBMISSION**

All Bid documents requiring signature must be signed in ink by an authorized representative.

Bids must be submitted in a sealed package or envelope. To ensure proper identification and handling, all packages and envelopes shall be clearly marked as follows:

Underwater Pier Repair Bid  
Closing Date & Time  
Bidder Legal Name  
Oregon CCB #

Port of Hood River  
Attn: John Mann  
1000 E. Port Marina Drive  
Hood River OR 97031

**BID WITHDRAWAL**

Bids may be withdrawn in writing submitted on the Bidder’s letterhead, signed by an authorized representative, and received by the Owner prior to closing. Offer withdrawals submitted in

writing must be labeled as such and contain the Project Name.

Bids may be withdrawn in person before Closing upon presentation of appropriate identification and evidence of authorization to act for Bidder. Signature confirmation of withdrawal may also be required.

**CLOSING & OPENING/FIRST TIER SUBMITTAL**

Bids will be received until 2:00 PM PDT on Thursday, March 30, 2023 where they will be immediately opened publicly and read aloud. Award decisions will not be made at Bid opening.

Bids received after 2:00 PM PDT on Thursday, March 30, 2023 will be non-responsive and not be opened.

First Tier subcontractors disclosure forms must be returned within two (2) working hours after closing, at the Port of Hood River office, 1000 E. Port Marina Drive, Hood River, Oregon. Failure to comply with this requirement shall result in rejection of the Bid as non-responsive.

Prior to the Intent to Award Announcement, the Port of Hood River may post preliminary bid results on the project page on the Oregon Buys website at <https://oregonbuys.gov/bsol/>. Such postings are preliminary and are not final until all submission materials are validated.

**BID ACCEPTANCE**

A Bid is a firm offer, irrevocable, valid and binding on the Bidder for not less than thirty (30) calendar days from the closing date.

The Port of Hood River may request, orally or in writing, that Bidders extend, in writing, the time during which the Port of Hood River may consider their Bid. If a bidder agrees to such extension, the Bid shall continue as a firm Bid, irrevocable, valid and binding on the Bidder for the agreed-upon extension period.

**METHOD OF AWARD**

The responsiveness and responsibility of Bidders and their proposed Subcontractors will be considered in making the award.

Base Bid, and alternates (if applicable), unless modified by addendum. The Port reserves the right to arrange the bid forms with alternates and additives, if such be to the advantage of the Port. The bidder shall bid on all alternates and additives set forth in the bid forms unless otherwise specified.

Award will be made to the lowest responsive and responsible bidder.

**BID EVALUATION CRITERIA**

Bids will be evaluated to identify the lowest responsive Bid submitted by a responsible Bidder and not otherwise disqualified. (Refer to OAR 137-049-0390). Adjustments made to account for reciprocal preferences will be for Offer evaluation purposes only. No such adjustments shall operate to amend Bidder's Bid or any Contract awarded pursuant thereto.

To be considered responsive, the Bidder must substantially comply in all material respects with applicable solicitation procedures and requirements and the solicitation documents. In making such evaluation, the Port of Hood River may waive minor informalities and irregularities.

Prior to award of a contract, the Port of Hood River will evaluate whether the apparent successful Bidder meets the applicable standards of responsibility identified in ORS 279C.375(2)(b) and OAR 137-049-0390. In doing so, the Port of Hood River may investigate the Bidder and request information in addition to that already required in the ITB, when the Port of Hood River, in its sole discretion, considers it necessary or advisable.

**BID SECURITY REQUIREMENTS**

A surety bond, irrevocable letter of credit issued by an insured institution as defined in ORS 706.008, cashier's or certified check, executed in favor of the Port of Hood River in the amount equal to ten percent (10%) of the total amount of the Bid, shall be submitted with or posted for all Bids as bid security unless the Contract has been exempted from this requirement under ORS 279C.390.

If the undersigned fails to (1) execute the contract, (2) furnish a Performance and Payment Bond, or (3) furnish the certificates of insurance within ten (10) calendar days of the written Notice of Intent-to-Award a Contract, then the Port of Hood River may cash the check, draw under the letter of credit or otherwise collect under the Bid Security.

**PROCESSING OF BIDS**

Neither the release of Bid Security, nor acknowledgement that the selection process is complete (whether by posting of a bid tabulation sheet, issuance of Notice of Intent to Award, or otherwise), shall operate as a representation by the Port of Hood River that any Bid submitted was complete, sufficient, lawful in any respect, or otherwise in substantial compliance with the ITB requirements.

**WITHDRAWAL OF BID ITEMS**

The Port of Hood River reserves the right to withdraw Bid items. The deletion of one or more bid items will not affect the method of award.

**REJECTION OF BIDS**

The Port of Hood River may reject all Bids for good cause upon finding that it is in the public interest to do so.

The Port of Hood River may reject a particular Bid for any reason listed under OAR 137-049-0440.

**INTENT-TO-AWARD ANNOUNCEMENT**

The Port of Hood River reserves the right to announce its Intent-to-Award prior to formal Contract award by posting the tabulation sheet of Bid results on the project page on the Oregon Buys website, <https://oregonbuys.gov/bsa/>, or by letter or fax. The Intent-to-Award Announcement shall serve as notice to all Bidders the Port of Hood River intends to make an award.

**PROTEST OF INTENT-TO-AWARD**

Adversely affected or aggrieved Bidders shall have seven (7) calendar days from the date of the Intent-to-Award Announcement within which to file a written protest. Protests submitted after that date will not be considered. Protests must specify the grounds upon which the protest is based.

In order to be an adversely affected or aggrieved Bidder, the Bidder must claim to be eligible for award of the contract as the lowest responsible and responsive Bidder and that any and all lower Bidders are ineligible to receive Contract award.

An Actual Bidder who is adversely affected or aggrieved by the award of the Contract to another Bidder may protest award, in writing, within the timeline established. The written protest shall state the grounds upon which the protest is based. No protest of award shall be considered after the deadline.

**RESPONSE TO INTENT-TO-AWARD PROTESTS**

The Port of Hood River will respond in writing to Intent-to-Award protests submitted by adversely affected or aggrieved Bidders. The Port of Hood River may also respond to Intent-to-Award protests submitted by other Bidders for the purpose of clarification. However, any response made by the Port of Hood River is not intended to, and shall not in and of itself constitute, confirmation that the Bidder is, in fact, adversely affected or aggrieved, and therefore entitled to protest an Intent-to-Award, or that the protest was timely filed.

**AWARD**

After expiration of the seven (7) calendar day Intent-to-Award protest period, and resolution of all protests, the Port of Hood River may proceed with final award. If the Port of Hood River receives only one Bid, the Port of Hood River may dispense with the Intent-to-Award protest period and proceed with award of a Contract.

**COMMENCEMENT OF WORK**

Contractor shall not commence Work under this Contract until the Notice to Proceed has been issued.

**REVIEW OF AWARDED BID FILES**

Awarded Bid files are public records and available for review at the Port of Hood River office by appointment during regular business hours (Monday through Friday, 8am until 5pm).

**INFORMATION TO BE SUBMITTED BY APPARENT SUCCESSFUL BIDDER**

The apparent successful Bidder shall provide all required proof of insurance to the Port of Hood River within ten (10) calendar days of notification of the Intent-to-Award. Failure to present the required documents within ten (10) calendar days may result in Bid rejection. Bidders are encouraged to consult their insurance agent about the insurance requirements as identified in Section G of the General Contract Conditions prior to Bid submission.

Bidders must satisfy these insurance requirements by obtaining insurance coverage from insurance companies or entities acceptable to the Port of Hood River that are allowed to provide such insurance under Oregon law.

The successful Bidder shall be required to furnish a Performance and Payment Bond each in the total amount of one hundred percent (100%) of the awarded contract, executed in favor of the Port of Hood River, to ensure faithful performance of the Contract and payment for services and goods.

The apparent low bidder shall provide all required bonding to the Port of Hood River within ten (10) calendar days of notification of Intent-to-Award. Failure to present the required documents within ten (10) calendar days may be grounds for award disqualification.

The apparent successful Bidder, if a Joint Venture/Partnership, shall provide a copy of the Joint Venture Agreement or Partnership Agreement evidencing authority to Offer and to enter into the resulting Contract that may be awarded, together with corporate resolutions (if applicable) evidencing corporate authority to participate as a Joint Venture or Partner. A contact person must also be designated for purposes of receiving all notices and communications under the Contract. All Partners and Joint Venturers will be required to sign the Contract awarded.

**OREGON PREVAILING WAGES RATES (BOLI REQUIREMENTS)**

The Contractor and subcontractors shall comply with all the provisions of 279C.800 through 279C.870, relative to Prevailing Wage Rates. The current Prevailing Wage Rates for Public Works Contract in Oregon subject to the State PWR will apply to this project and can be found at:

<https://www.oregon.gov/boli/employers/pages/prevailing-wage.aspx>

The work takes place in Hood River County.

**FIRST-TIER SUBCONTRACTOR DISCLOSURE INSTRUCTIONS AND FORM**

Pursuant to ORS 279C.370, Bidders are required to disclose information about certain First-Tier Subcontractors when the Owner estimates the contract value for a Public Improvement to be

greater than \$100,000. Specifically, when the Contract amount of a First-Tier Subcontractor furnishing labor, or labor and materials, has a Contract value that is equal to or greater than five percent (5%) of the total project bid or \$15,000, whichever is greater, or \$350,000 regardless of the percentage of the total project bid, the Bidder must disclose the following information about that Subcontract in its Bid submission or within two (2) working hours after Bid Closing:

- a) Subcontractor's name;
- b) Category of work that Subcontractor would be performing;
- c) Dollar value of each Subcontract.

If the Bidder will not be using any subcontractors that are subject to the above disclosure requirements, the Bidder is required to write "NONE" on the Disclosure Form.

The Port of Hood River must reject a Bid if the Bidder fails to submit the disclosure form with this information by the stated deadline.

The Bidder must submit the Disclosure Form required by OAR 137-049-0360 either in its Bid submission or within two (2) working hours after closing.

The Port of Hood River shall obtain, and make available for public inspection, the Disclosure Forms required by OAR 137-049-0360. The Port of Hood River shall also provide copies of the Disclosure Forms to the Bureau of Labor and Industries as required by ORS 279C.835. The Port of Hood River is not required to determine the accuracy or completeness of the information submitted. Substitution of affected first-tier subcontractors shall be made only in accordance with ORS 279C.585.

**PART 4**

**BID FORM, BID SHEET, CONTRACTOR REGISTRATION FORM, AND  
FIRST TIER SUBCONTRACTOR DISCLOSURE FORM**

**BID FORM**

DATE: 3/30/2023

**PORT OF HOOD RIVER  
1000 E. PORT MARINA DRIVE  
HOOD RIVER, OREGON 97031**

**PRICE SUBMITTAL:**

The Undersigned proposes and agrees, if this Bid is accepted, to enter into an agreement with the Port of Hood River to furnish all Work as specified or indicated herein for the ITB indicated and within the schedule indicated in the Invitation to Bid. Bidder has familiarized itself with the Work and has visited and inspected the site and is familiar with all the field conditions, legal requirements (federal, state, and local laws, ordinances, rules and regulations), and conditions affecting cost, progress and performance of work, and has made such independent investigations as Bidder deems necessary. Bidder has given the Port written notice of all conflicts, errors, and/or discrepancies that it has discovered in the Contract Documents and the written resolution thereof by the Port is acceptable to Bidder.

**BASE BID: Underwater Pier Repair**

FOR THE LUMP SUM OF: \$ Four Hundred and Sixty Five Thousand Dollars (\$465,000.00)

**CHANGES TO THE WORK**

- A. If adjustments to the work occur, the Bid Sheet will be used for basis of cost adjustment. If quantities are adjusted by more than 25% equitable overhead factor may be applied.

The Undersigned agrees, if awarded the Contract, to complete this work not later than:

6/30, 2023.

Company: Advanced American Construction Telephone: 503-445-9000

Company Address: 8444 NW St Helens Rd, Portland OR 97231

Email: bid@callaac.com Fax: 503-546-3031

Construction Contractors Board Number 167886 Expiration Date 1/4/2024

I attest that I have the authority to commit the firm named above to this Bid amount and acknowledge that the firm meets the qualifications necessary to perform this work as outlined in the Invitation to Bid. I understand that I will be required to provide necessary information to verify that the firm meets these qualifications if selected for the Contract.

By: Dee Bond PRESIDENT 3/28/23

---

Signature / Name & Title / Date



### BID SHEET

Item	Description	Qty	Unit	Unit Cost	Total
1	Underwater Concrete Repair	1	LS	465,000	465,000.00
<b>Total Bid</b>					465,000.00
<b>Written Bid Total:</b> <i>Four Hundred and Sixty Five Thousand Dollars</i>					

Contractor Name	Advanced American Construction
Address	8444 NW St Helens Rd, Portland OR 97231
Address	
City, State, Zip	Portland OR 97231
Phone	503-445-9000
Fax	503-546-3031
Email	bid@callaac.com
Registration Number	<i>93-1295688</i>
Contact	Jon Koller
Phone	503-729-6720

**CONTRACTOR REGISTRATION FORM**

This Bid must be signed in ink by an authorized representative of the Bidder; any alterations or erasures to the Bid must be initialed in ink by the undersigned authorized representative.

**1. CCB Requirements**

All Bidders shall be licensed with the State of Oregon Contractors Board (CCB) prior to bidding on Public Improvement Contracts. Failure to comply with this requirement shall result in Bid Rejection.

All subcontractors participating in the project shall be similarly registered with the State of Oregon Contractors Board at the time they propose to engage in subcontract work. The CCB registration requirements apply to all public works contracts unless superseded by federal law.

**Construction Contractors Board Number:** 167886  
**Expiration Date:** 1/4/24

**2. Asbestos Abatement Licensing Requirements**

An asbestos abatement license under ORS 468A.720 will not be required of the Contractor or its subcontractors.

**3. Joint Venture/Partnership Disclosure**

The Undersigned has authority on behalf of the following entity and is (check one of the following and insert information requested):

- a. A corporation organized and existing under the laws of the State of OR; or
- b. A partnership/joint venture registered under the laws of the State of \_\_\_\_\_; If yes, name of the contact person for the partnership/joint venture \_\_\_\_\_; or
- c. A limited liability corporation (LLC) or limited liability partnership (LLP) under the laws of the State of \_\_\_\_\_; or
- d. An individual doing business under an assumed name registered under the laws of the State of \_\_\_\_\_.

**4. Addendum or Addenda Acknowledgement**

ADDENDA: The Undersigned hereby acknowledges receipt of the following Addenda:

ADDENDUM NO.	DATED	ADDENDUM NO.	DATED
<u>Addendum 01</u>	<u>3/9/2023</u>	_____	_____
<u>Addendum 02</u>	<u>3/23/2023</u>	_____	_____
_____	_____	_____	_____
_____	_____	_____	_____

**5. Responsibility Inquiry/ Contractor References**

(Provide (5) related project references and contact information)

**6. Recycled Products**

Bidder will comply with the recycled products provision in the Invitation to Bid in accordance with ORS 279A.125. Contractors shall use recyclable products to the maximum extent economically feasible in the performance of the contract work as set forth in this document.

**7. Residency Information**

Bidder is a (X) Resident Bidder ( ) Non-resident Bidder

If a Resident Bidder, enter your Oregon business address:

8444 NW St Helens Rd, Portland OR 97231

If a Non-resident Bidder, enter State of residency: \_\_\_\_\_

**8. Compliance with Tax Laws**

By my signature, I hereby attest or affirm under penalty of perjury: that I am authorized to act on behalf of the Contractor in this matter, that I have authority and knowledge regarding the payment of taxes, and that Contractor is, to the best of my knowledge, not in violation of any Oregon Tax Laws and any local tax laws administered by the Oregon Department of Revenue under ORS 305.620.

**9. Certification of Drug-Testing Law Requirements**

By my signature, I certify that Contractor shall demonstrate that an employee drug testing program is in place.

**10. Certification of Compliance with Non-Discrimination Laws**

By my signature, I hereby attest or affirm under penalty of perjury: that I am authorized to act on behalf of Contractor in this matter, and to the best of my knowledge, the Contractor has not discriminated against minority, women or emerging small business enterprises in obtaining any required subcontracts, and that the Contractor is not in violation of any Discrimination Laws.

**11. Signature of Bidder's Duly Authorized Representative**

The Bid must be signed in ink by an authorized Representative of the Bidder. Any alterations or erasures to the bid must be initialed in ink by the undersigned authorized representative.

The undersigned acknowledges, attests and certifies individually and on behalf of the Bidder that:

1. He/She is a duly authorized representative of the Bidder, has been authorized by Bidder to make all representations, attestations, and certifications contained in this Bid and all Addendum or Addenda, if any, issued.
2. Bidder, acting through its authorized representatives, has read and understands all Bid instructions, specifications, plans, terms and conditions contained in this Bid document, including all attachments, exhibits, and Addenda, if any, issued.
3. The Bid submitted is in response to the specific language contained in the Invitation to Bid, and Bidder has made no assumptions based upon either (a) verbal or written statements not contained in the Invitation to Bid, or (b) any previously issued Invitation to Bid, if any.
4. The Owner shall not be liable for any claims or be subject to any defenses asserted by Bidder based upon, resulting from, or related to, Bidder's failure to comprehend all the requirements of the Invitation to Bid.
5. The Owner shall not be liable for any expenses incurred by Bidder in preparing and submitting its Bid or in participating in the Bid evaluation/selection process.
6. The Bidder agrees to be bound by and comply with all applicable requirements of ORS 279C.800 through ORS 279C.870 and the administrative rules of the Bureau of

Labor and Industries (BOLI) regarding prevailing wage rates and payment of a fee to BOLI.

7. The Bid was (1) prepared independently from all other Bidders, and without collusion, fraud, or other dishonesty and without any agreement, understanding, or planned common course of action with, any other vendor of materials, supplies, equipment, or services described in the Invitation to Bid designed to limit independent bidding or competition; and (2) the contents of this Bid have not been communicated by the Undersigned or its employees or agents to any person not an employee or agent of the Undersigned or its surety on any bond furnished with the Bid and will not be communicated to such person prior to the official opening of the Bids.
8. Bidder is bound by and will comply with all requirements, specifications, plans, terms and conditions contained in this Bid, including all attachments, exhibits and Addendum or Addenda, if any, issued.
9. Bidder will furnish the designated items and/or services in accordance with the Bid specifications, plans, and requirements, and will comply in all respects with the terms of the resulting Contract upon award.  
Bidder represents and warrants that Bidder has the power and authority to enter into and perform the Contract and that the Contract, when executed and delivered, shall be a valid and binding obligation of Contractor enforceable in accordance with its terms.
10. All affirmations and certifications contained in sections 6,7,8,9 and 10 are true and correct.

Authorized Signature Marvin D. Burch Title President

---

FEIN ID # or SSN # 543-70-4528

Contact Person: Marvin D. Burch

Telephone Number (503)445-9000 Fax (503)546-3031

**FIRST-TIER SUBCONTRACTOR DISCLOSURE FORM**

**Project Name** Port of Hood River Underwater Pier Repair

**Bid Opening Date** March 30th, 2023

**Name of Bidding Contractor** Advanced American Construction

**Email Address** Bid@callaac.com

CHECK THIS BOX IF YOU WILL NOT BE USING ANY FIRST-TIER SUBCONTRACTORS OF IF YOU ARE NOT SUBJECT TO THE DISCLOSURE REQUIREMENTS (SEE INSTRUCTIONS).

**FIRST-TIER SUBCONTRACTORS**

<b>Firm Name</b>	<b>Dollar Amount</b>
<b>Category of Work</b>	

<b>Firm Name</b>	<b>Dollar Amount</b>
<b>Category of Work</b>	

<b>Firm Name</b>	<b>Dollar Amount</b>
<b>Category of Work</b>	

<b>Firm Name</b>	<b>Dollar Amount</b>
<b>Category of Work</b>	

<b>Firm Name</b>	<b>Dollar Amount</b>
<b>Category of Work</b>	

**BID BOND FORM**

**Project Name: Underwater Pier Repair**

We, Advanced American Construction, Inc., as "Principal,"  
(Name of Principal)

And Western Surety Company, an South Dakota Corporation,  
(Name of Surety)

authorized to transact Surety business in Oregon, as "Surety," hereby jointly and severally bind ourselves, our respective heirs, executors, administrators, successors and assigns to pay unto the Port of Hood River ("Obligee") the sum of (\$ ----- 5% -----)  
Five percent of the total amount bid dollars.

NOW, THEREFORE, if the bid submitted by Principal is accepted, and if a contract pursuant to the bid is awarded to Principal, and if Principal enters into and executes such contract within the time specified in the procurement document and executes and delivers to Obligee its good and sufficient performance and payment bonds required by Obligee, as well as any required proof of insurance, within the time fixed by Obligee, then this obligation shall be void; otherwise, it shall remain in full force and effect.

IN WITNESS WHEREOF, we have caused this instrument to be executed and sealed by our duly authorized legal representatives this 24th day of March, 2023.

**PRINCIPAL:** Advanced American Construction, Inc.

**SURETY:** Western Surety Company

By *Dea Burt*  
Signature

BY ATTORNEY-IN-FACT:

*PRESIDENT*  
Official Capacity

Katrina Green  
Name

Attest: \_\_\_\_\_  
Corporation Secretary

*Katrina M Green*  
Signature

151 N. Franklin Street  
Address

Chicago IL 60606  
City State Zip

800-925-2044 503-431-3006  
Phone Fax

# Western Surety Company

## POWER OF ATTORNEY APPOINTING INDIVIDUAL ATTORNEY-IN-FACT

Know All Men By These Presents, That WESTERN SURETY COMPANY, a South Dakota corporation, is a duly organized and existing corporation having its principal office in the City of Sioux Falls, and State of South Dakota, and that it does by virtue of the signature and seal herein affixed hereby make, constitute and appoint

**Gregory C Ryerson, Kristine Calvin, Katrina M Green, Melissa C Hall, Deborah Robinson, Individually**

of Portland, OR, its true and lawful Attorney(s)-in-Fact with full power and authority hereby conferred to sign, seal and execute for and on its behalf bonds, undertakings and other obligatory instruments of similar nature

### - In Unlimited Amounts -

and to bind it thereby as fully and to the same extent as if such instruments were signed by a duly authorized officer of the corporation and all the acts of said Attorney, pursuant to the authority hereby given, are hereby ratified and confirmed.

This Power of Attorney is made and executed pursuant to and by authority of the By-Law printed on the reverse hereof, duly adopted, as indicated, by the shareholders of the corporation.

In Witness Whereof, WESTERN SURETY COMPANY has caused these presents to be signed by its Vice President and its corporate seal to be hereto affixed on this 29th day of March, 2022.



WESTERN SURETY COMPANY

*Paul T. Bruflat*

Paul T. Bruflat, Vice President

State of South Dakota }  
County of Minnehaha } ss

On this 29th day of March, 2022, before me personally came Paul T. Bruflat, to me known, who, being by me duly sworn, did depose and say: that he resides in the City of Sioux Falls, State of South Dakota; that he is the Vice President of WESTERN SURETY COMPANY described in and which executed the above instrument; that he knows the seal of said corporation; that the seal affixed to the said instrument is such corporate seal; that it was so affixed pursuant to authority given by the Board of Directors of said corporation and that he signed his name thereto pursuant to like authority, and acknowledges same to be the act and deed of said corporation.

My commission expires

March 2, 2026

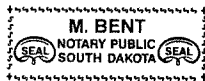

*M. Bent*

M. Bent, Notary Public

### CERTIFICATE

I, L. Nelson, Assistant Secretary of WESTERN SURETY COMPANY do hereby certify that the Power of Attorney hereinabove set forth is still in force, and further certify that the By-Law of the corporation printed on the reverse hereof is still in force. In testimony whereof I have hereunto subscribed my name and affixed the seal of the said corporation this 24<sup>th</sup> day of March, 2023.



WESTERN SURETY COMPANY

*L. Nelson*

L. Nelson, Assistant Secretary

**Authorizing By-Law**

**ADOPTED BY THE SHAREHOLDERS OF WESTERN SURETY COMPANY**

This Power of Attorney is made and executed pursuant to and by authority of the following By-Law duly adopted by the shareholders of the Company.

Section 7. All bonds, policies, undertakings, Powers of Attorney, or other obligations of the corporation shall be executed in the corporate name of the Company by the President, Secretary, and Assistant Secretary, Treasurer, or any Vice President, or by such other officers as the Board of Directors may authorize. The President, any Vice President, Secretary, any Assistant Secretary, or the Treasurer may appoint Attorneys in Fact or agents who shall have authority to issue bonds, policies, or undertakings in the name of the Company. The corporate seal is not necessary for the validity of any bonds, policies, undertakings, Powers of Attorney or other obligations of the corporation. The signature of any such officer and the corporate seal may be printed by facsimile.



# Port of Hood River Underwater Pier Repair

Request for Proposal

March 30, 2023



## Past Performance

### Lower Monumental Dam RSW (2006)

- US Army Corps of Engineers- Walla Walla District
- 201 N 3rd Ave, Walla Walla, WA 99362 - (509) 527-7020
- One of only three in the world, the Removable Spillway Weir (RSW) consisted of a 2 million pound, 120 feet high, 80 feet wide and 70 feet deep, high-performance coated structure delivered and attached to the Lower Monumental Dam Spillway #8. AAC's dive crew drilled and grouted over 500 each undercut anchors installed underwater; 60 rock bolts; 16 each rock anchors that were 53-feet in length and installed in 120 feet of water; mechanical building; and a complex ballasting and anchoring system to install the RSW with significant mechanical and electrical work. AAC's dive crews were also used to install hinge frame components; underwater concrete placement; seismic restraint bracket installation; RSW seal and bearing pad installation; underwater mechanical piping installation; and deployment and installation of the RSW itself.

### Ice Harbor Dam Spillway Chute (2015)

- US Army Corps of Engineers Burbank, WA
- 2339 Ice Harbor Dr, Burbank, WA 99323 - (509) 547-7781
- Advanced American Construction was the General Contractor for the Ice Harbor Dam Spillway Deflector Mods project. The project involved re-sloping Spill bay 2 at Ice Harbor Dam to compensate for adjusted flows caused by the Removable Spillway Weir attached to the upstream side of the spill bay. The biggest challenge to overcome was the steep slope of the existing spillway surface, as well as the shape of the new spillway surface, which was given as a parabolic curve equation with a tolerance of 1/4". In order to set up containment for the project AAC had to set up a cofferdam system sitting directly on the concrete slope. As the bottom of the sheet piling would sit underwater AAC had to devise a seal to prevent the system from leaking. AAC Divers set up a sill for the sheet pile to sit in and grouted them in place underwater. This was able to set up the means for which the project could be completed.

### **Buffalo Bill Powerplant Tailrace Repairs (2015)**

- Bureau of Reclamation, Great Plains Region
- 2021 4th Ave N Ste 3, Billings, MT 59101. Gerri Voto-Braun (406)-247-7809
- The main purpose of the project was to repair and prevent future erosion of the stilling basin apron. The weather was extremely cold (down to -20 degrees F). AAC performed extensive dive operations repairing concrete underwater. During the installation of the armor plate system divers drilled and grouted in place hundreds of anchor bolts and backfill grouted the armor plate into position as well. AAC Divers also performed inspections, cleaning and debris removal, layout, and seal welding for the new system.

### **G.P. Camas Mill Effluent Line Grout Support (2023)**

- Georgia Pacific
- 401 NE Adams St. Camas, WA 98607. Todd Drenth - (360)-834-8304
- AAC performed underwater work to mitigate the scouring and settling of the Effluent line in the slough. Work items included rotating ballast blocks back to proper orientation, relocation of wood debris in the repair area, placement of grout bags for block support and pipe support, filling the bags with grout mix from concrete trucks and a line pump on the mill property.

### **Columbia Pacific Construction -Kelso Levee (2022)**

- Columbia Pacific Construction
- 175 Hansen Ln, Woodland, WA 98674. Justin Krueger – (360) 624-6180
- AAC performed a dive inspection and concrete repair of the levee. The diver performed an inspection of current pipe condition noting any discrepancies. The diver then jet cleaned the area for pipe installation and proceeded to install plug and backers. AAC then returned after the pour to inspect the plugs.

**PART 6**  
**PERFORMANCE BOND FORM**  
**PAYMENT BOND FORM**

**PERFORMANCE BOND FORM**

Bond No. \_\_\_\_\_  
Solicitation \_\_\_\_\_  
Project Name: Underwater Pier Repair \_\_\_\_\_

\_\_\_\_\_ (Surety #1)      Bond Amount No. 1:      \$ \_\_\_\_\_

\_\_\_\_\_ (Surety #2)\*      Bond Amount No. 2:\*      \$ \_\_\_\_\_

- *If using multiple sureties*

Total Penal Sum of Bond \$ \_\_\_\_\_

We, \_\_\_\_\_, as Principal, and the above identified Surety(ies), authorized to transact surety business in Oregon, as Surety, hereby jointly and severally bind ourselves, our respective heirs, executors, administrators, successors and assigns firmly by these presents to pay unto the Port of Hood River the sum of (Total Penal Sum of Bond) \_\_\_\_\_ (Provided, that we the Sureties bind ourselves in such sum "jointly and severally" as well as "severally" only for the purpose of allowing a joint action or actions against any or all of us, and for all other purposes each Surety binds itself, jointly and severally with the Principal, for the payment of such sum only as is set forth opposite the name of such surety), and

WHEREAS, the Principal has entered into a contract with the Port of Hood River, the plans, specifications, terms and conditions of which are contained in above-referenced Solicitation;

WHEREAS, the terms and conditions of the contract, together with applicable plans, standard specifications, special provisions, schedule of performance, and schedule of contract prices, are made a part of this Performance Bond by reference, whether or not attached to the contract (all hereafter called "Contract"); and

WHEREAS, the Principal has agreed to perform the Contract in accordance with the terms, conditions, requirements, plans and specifications, and all authorized modifications of the Contract which increase the amount of the work, the amount of the Contract, or constitute an authorized extension of the time for performance, notice of any such modifications hereby being waived by the Surety;

NOW, THEREFORE, THE CONDITION OF THIS BOND IS SUCH that if the Principal herein shall faithfully and truly observe and comply with the terms, conditions and provisions of the Contract, in all respects, and shall well and truly and fully do and perform all matters and things undertaken by Contractor to be performed under the Contract, upon the terms set forth therein, and within the time prescribed therein, or as extended as provided in the Contract, with or without notice to the Sureties, and shall indemnify and save harmless the Port of Hood River and members thereof, its officers, employees and agents, against any direct or indirect damages or claim of every kind and description that shall be suffered or claimed to be suffered in connection with or arising out of the performance of the Contract by the Principal or its subcontractors, and shall in all respects perform said Contract according to law, then this obligation is to be void; otherwise it shall remain in full force and effect.

Nonpayment of the bond premium will not invalidate this bond nor shall the Port of Hood River be obligated for the payment of any premiums.

This bond is given and received under authority of ORS Chapter 279C, the provisions of which hereby are incorporated into this bond and made a part thereof.

IN WITNESS WHEREOF, WE HAVE CAUSED THIS INSTRUMENT TO BE EXECUTED AND SEALED BY OUR DULY AUTHORIZED LEGAL REPRESENTATIVES:

Dated this \_\_\_\_\_ day of \_\_\_\_\_, 20\_\_\_\_\_.

**PRINCIPAL:** \_\_\_\_\_

By: \_\_\_\_\_  
Signature

\_\_\_\_\_  
Official Capacity

Attest: \_\_\_\_\_  
Corporation Secretary

**SURETY:** \_\_\_\_\_  
*[Add signatures for each if using multiple bonds]*

**BY ATTORNEY-IN-FACT:**  
*[Power-of-Attorney must accompany each bond]*

\_\_\_\_\_  
Name

\_\_\_\_\_  
Signature

\_\_\_\_\_  
Address

\_\_\_\_\_  
City State Zip

\_\_\_\_\_  
Phone Fax

**PAYMENT BOND FORM**

Bond No. \_\_\_\_\_  
Solicitation \_\_\_\_\_  
Project Name: Underwater Pier Repair \_\_\_\_\_

\_\_\_\_\_ (Surety #1)      Bond Amount No. 1:      \$ \_\_\_\_\_  
\_\_\_\_\_ (Surety #2)\*      Bond Amount No. 2:\*      \$ \_\_\_\_\_

- *If using multiple sureties*

Total Penal Sum of Bond \$ \_\_\_\_\_

We, \_\_\_\_\_, as Principal, and the above identified Surety(ies), authorized to transact surety business in Oregon, as Surety, hereby jointly and severally bind ourselves, our respective heirs, executors, administrators, successors and assigns firmly by these presents to pay unto the Port of Hood River the sum to (Total Penal Sum of Bond) \_\_\_\_\_ (Provided, that we the Sureties bind ourselves in such sum "jointly and severally" as well as "severally" only for the purpose of allowing a joint action or actions against any or all of us, and for all other purposes each Surety binds itself, jointly and severally with the Principal, for the payment of such sum only as is set forth opposite the name of such surety), and

WHEREAS, the Principal has entered into a contract with the Port of Hood River, the plans, specifications, terms and conditions of which are contained in above-referenced Solicitation;

WHEREAS, the terms and conditions of the contract, together with applicable plans, standard specifications, special provisions, schedule of performance, and schedule of contract prices, are made a part of this Payment Bond by reference, whether or not attached to the contract (all hereafter called "Contract"); and

WHEREAS, the Principal has agreed to perform the Contract in accordance with the terms, conditions, requirements, plans and specifications, and schedule of contract prices which are set forth in the Contract and any attachments, and all authorized modifications of the Contract which increase the amount of the work, or the cost of the Contract, or constitute authorized extensions of time for performance of the Contract, notice of any such modifications hereby being waived by the Surety;

NOW, THEREFORE, THE CONDITION OF THIS BOND IS SUCH that if the Principal shall faithfully and truly observe and comply with the terms, conditions and provisions of the Contract, in all respects, and shall well and truly and fully do and perform all matters and things by it undertaken to be performed under said Contract and any duly authorized modifications that are made, upon the terms set forth therein, and within the time prescribed therein, or as extended therein as provided in the Contract, with or without notice to the Sureties, and shall indemnify and save harmless the Port of Hood River and members thereof, its officers, employees and agents, against any claim for direct or indirect damages of every kind and description that shall be suffered or claimed to be suffered in connection with or arising out of the performance of the Contract by the Contractor or its subcontractors, and shall promptly pay all persons supplying labor, materials or both to the Principal or its subcontractors for prosecution of the work provided in the Contract; and shall promptly pay all contributions due the State Industrial Accident Fund and the State Unemployment Compensation Fund from the Principal or its subcontractors in connection with the performance of the Contract; and shall pay over to the Oregon Department of Revenue all sums required to be deducted and retained from the wages of employees of the Principal and its subcontractors pursuant to ORS 316.167, and shall permit no lien nor claim to be filed or prosecuted against the Port of Hood River on account of any labor or materials furnished; and shall do all things required of the Principal by the laws of this State, then this obligation shall be void; otherwise, it shall remain in full force and effect.

Nonpayment of the bond premium will not invalidate this bond nor shall the Port of Hood River be obligated for the payment of any premiums.

This bond is given and received under authority of ORS Chapter 279C, the provisions of which hereby are incorporated into this bond and made a part thereof.

IN WITNESS WHEREOF, WE HAVE CAUSED THIS INSTRUMENT TO BE EXECUTED AND SEALED BY OUR DULY AUTHORIZED LEGAL REPRESENTATIVES:

Dated this \_\_\_\_\_ day of \_\_\_\_\_, 20\_\_\_\_\_.

**PRINCIPAL:** \_\_\_\_\_

By: \_\_\_\_\_  
Signature

\_\_\_\_\_  
Official Capacity

Attest: \_\_\_\_\_  
Corporation Secretary

**SURETY:** \_\_\_\_\_  
*[Add signatures for each if using multiple bonds]*

**BY ATTORNEY-IN-FACT:**  
*[Power-of-Attorney must accompany each bond]*

\_\_\_\_\_  
Name

\_\_\_\_\_  
Signature

\_\_\_\_\_  
Address

\_\_\_\_\_  
City State Zip

\_\_\_\_\_  
Phone Fax

**PART 7**  
**CERTIFICATE OF INSURANCE FORM**



**CERTIFICATE OF INSURANCE FORM**

This is to certify to: Port of Hood River, 1000 E. Port Marina Drive, Hood River OR 97031  
 That the following described policy or policies have been issued to:

\_\_\_\_\_  
 Name and Address of Insured

\_\_\_\_\_  
 Name and Address of Insurance Company

Description of Contract \_\_\_\_\_

Types of Coverages		Limits of Liability	Policy Number	Expiration Date
<b>1. Workers Compensation</b>		<b>Statutory</b>		
<b>2. Employer's Liability</b>		\$		
<b>3. Comprehensive General Liability</b>		<b>Bodily Injury</b>		<b>Property Damage</b>
	<b>A. Premises &amp; Operations</b>	\$		\$
	<b>B. Blanket Contractual</b>	\$		\$
	<b>C. Independent Sub-Contractors</b>	\$		\$
	<b>D. Products Liability &amp; Completed Operations</b>	\$		\$
<b>4. Comprehensive Automobile Liability (owner, hired, &amp; non-owned)</b>				
<b>5. Other-Builders Risk</b>				
<b>6. Jones Act and USLHWA Insurance</b>	<b>If applicable</b>			

Expires 12:01 Standard Time at the address of name insurance stated herein.

\*Indicate the following property liability features:

	<u>Yes</u>	<u>No</u>
1. "Broadform" including occurrence and care, custody and control.	___	___
2. Explosion, collapse and underground damage exclusions.	___	___

The insurer agrees that it will notify in writing, \_\_\_\_\_ of any material change, expiration or cancellation of the above-described policies not less than thirty (30) days before such change, expiration or cancellation becomes effective. It is further agreed the above named owner, his officers, agent (including his engineer) and employees are included as additional named insureds, but only as respects the performance of the above-described contract.

\_\_\_\_\_  
 Name of Insurance Company

\_\_\_\_\_  
 Authorized Representative

**PART 8**  
**GENERAL CONDITIONS (A-L)**

# PORT OF HOOD RIVER GENERAL CONDITIONS FOR PUBLIC WORKS CONTRACTS

## SECTION A General Provisions

### **DEFINITION OF TERMS**

**Alternate** – One of two or more units of work or groups of bid items, identified separately in the proposal, from which Owner may make a choice between different methods or material of construction for performing the same work.

**Architect/Engineer**-person appointed by the Port to make drawings and specifications, and to provide contract administration of the Work contemplated by this Contract.

**Bid**-an offer in connection with an invitation to bid and a proposal in connection with a request for proposals.

**Bidder**-means an Offeror in connection with an invitation to bid and proposer in connection with a request for proposals.

**Change Order**-written order issued by the Port's Authorized Representative to the Contractor requiring a change in the Work within the general scope of the Contract Documents.

**Claim**-means a demand by Contractor for review of the denial of Contractor's initial request for an adjustment of the Contract terms, payment of money, extension of Contract Time or other relief.

**Contract**- the written agreement between the Port and the Contractor comprised of the Contract Documents which describe the Work to be done and the obligations between the parties.

**Contract Documents**-means the solicitation Documents and addenda thereto, the Port of Hood River Public Improvement Contract, General Conditions, Supplemental General Conditions, if any, the accepted Bid, Plans, Specifications, amendments and change orders.

**Contract Period**- as set forth in the Contract Documents, means the period of time beginning with the issuance of the Notice to Proceed and concluding upon Final Completion.

**Contract Price**- the total of the awarded Bid amount, as increased or decreased by the price of approved alternatives and change orders.

**Contract Time**-means any incremental period of time allowed under the Contract to complete any portion of the Work reflected in the project schedule.

**Contractor**-person awarded the Contract for Work contemplated.

**Days**-are calendar days, unless otherwise specified.

**Direct Costs**-means the costs of materials, including sales tax, cost of delivery; cost of labor, including social security, unemployment insurance, and fringe benefits required by agreement or custom; worker's compensation insurance; project specific insurance; bond premiums, rental cost of equipment, and machinery required for execution of the work; and the additional costs of field personnel directly attributable to the Work.

**Final Completion**-means completion of all requirements under the Contract, excluding Warranty Work, and the final payment and release of retainage.

**Force Majeure**-means an act, event or occurrence caused by fire, riot, war, acts of God, nature, sovereign, or public enemy, strikes, freight embargoes or any other act, event or occurrence that is beyond the control of the party to this Contract who is asserting Force Majeure.

**Notice to Proceed**-the official written notice from the Port stating that the Contractor is to proceed with the Work defined in the Contract Documents.

**Offer**-a bid in connection with an invitation to bid and a proposal in connection with a request for proposals.

**Offeror**-means a bidder in connection with an invitation to bid and proposer in connection with a request for proposals.

**Overhead**-those items which may be included in the Contractor's markup and that shall not be charged as Direct Cost of Work, including without limitation such Overhead expenses as wages or salary of personnel above the level of foreman and expenses of the Contractor's office at the job site including expenses of personnel staffing the job site office.

**Owner**-Port of Hood River.

**Owner's (Port's) Authorized Representative**-those individuals identified in writing by the Owner to act on behalf of the Owner for this project.

**Person**-an entity doing business as a sole proprietorship, a partnership, a joint venture, a corporation, a limited liability company or partnership, or any other entity possessing the legal capacity to contract.

**Plans**-the drawings which show the location, type, dimensions, and details of the Work to be done under this Contract.

**Punchlist**-the list of Work yet to be completed or deficiencies which need to be corrected in order to achieve Final Completion of the Contract.

**Record Document**-means the as-built Plans, Specifications, testing and inspection records, product test data, samples, manufacturer and distributor/supplier warranties evidencing transfer to Owner, operational and maintenance manuals, shop drawings, Change Orders, correspondence, certificates of occupancy, and other documents listed in section B of these General Conditions, recording all services performed.

**Solicitation Document**-means invitation to bid or request for proposal or request for quotes.

**Specification**-means any description of the physical or functional characteristics of the Work, or of the nature of a supply, service or construction item. Specifications may include a description of any requirement for inspecting, testing or preparing a supply, service or construction item for delivery and the quantities or qualities of materials to be furnished under the Contract. Specifications will generally state the results or products to be obtained and may describe the method and manner of doing the work to be performed.

**Subcontractor**- a person having a direct contract with the Contractor, or another subcontractor, to perform one or more items of the Work.

**Substantial Completion**-the date when the Owner accepts in writing the construction, alteration, or repair of the improvement to real property or any designated portion thereof as having reached the state of completion when it may be used or occupied for its intended purpose. Substantial Completion of facilities with operating systems occurs only after thirty (30) continuous days of successful, trouble-free operation.

**Substitutions**- items that in function, performance, reliability, quality, and general configuration are the same or better than the product specified.

**Supplemental General Conditions**-those conditions that remove from, add to, or modify these General Conditions.

**Work**- the furnishing of all materials, equipment, labor, transportation, services and incidentals necessary to successfully complete any individual item or the entire Contract and the carrying out of duties and obligations imposed by the Contract Documents.

## **SCOPE OF WORK**

The work contemplated under this Contract includes all labor, materials, transportation, equipment and services for, and incidental to, the completion of all construction work in connection with the project described in the Contract Documents. The Contractor shall perform all Work necessary so that the project can be legally occupied and fully used for the intended use set forth in the Contract Documents.

## **INTERPRETATION OF CONTRACT DOCUMENTS**

Unless otherwise specifically defined in the Contract Documents, words which have well-known technical meanings or construction industry meanings are used in the Contract Documents in accordance with such recognized meanings. Contract documents are intended to be complimentary. Whatever is called for in one, is interpreted to be called for in all. However, in the event of conflicts or discrepancies among Contract Documents, interpretations will be based on the following descending order of precedence:

1. Contract amendments and Change Orders, with those of later date having precedence over those of an earlier date;
2. The Port of Hood River Public Improvement Contract;
3. The Plans and Specifications;
4. The General Conditions;
5. The Solicitation Document and any addenda thereto;
6. The Accepted Offer.

In the case of an inconsistency between the Plans and Specifications or within either document not clarified by addendum, the better quality or greater quantity of Work shall be provided in accordance with the Owner or Owner's Authorized Representative's interpretation in writing.

If the Contractor finds discrepancies in or omissions from the Contract Documents, or if the Contractor is in doubt as to their meaning, the Contractor shall at once notify the Owner or the Owner's Authorized Representative. Matters concerning performance under, and interpretation of requirements of, the Contract Documents will be decided by the Owner's Authorized Representative, who may delegate that duty in some instances to the Architect/Engineer. Responses to the Contractor's request for interpretation of Contract Documents will be made in writing by the Owner's Authorized representative within any time limits agreed upon or otherwise with reasonable promptness. Interpretations and decisions of the Owner's Authorized Representative will be consistent with the intent of and reasonably inferable from the Contract Documents. Contractor shall not proceed without direction in writing from the Owner's Authorized Representative.

## **EXAMINATION OF PLANS, SPECIFICATIONS, AND SITE**

It is understood that the Contractor, before submitting a bid, has made careful examination of the Contract Documents; has become fully informed as to the quality and quantity of materials and the character of the Work required; and has made a careful examination of the location and conditions of the Work and the sources of supply for materials. The Owner will in no case be responsible for any loss or for any unanticipated costs that may be suffered by the Contractor as a result of the Contractor's failure to acquire full information in advance in regard to all conditions pertaining to the Work.

## **SECTION B**

### Administration of the Contract

## **PORT'S ADMINISTRATION OF THE CONTRACT**

The Port's Authorized Representative will provide administration of the Contract as described in the Contract documents (1) during construction, (2) until final payment is due and (3) during the one-year period for correction of work. The Port's Authorized Representative will act on behalf of the Port to the extent provided in the Contract Documents, unless modified in writing in accordance with other provisions of the contract. In performing these tasks, the Port may rely on the Architect/Engineer or other consultants to perform some or all of these tasks.

The Port's Authorized Representative will visit the site at intervals appropriate to the stage of the Contractor's operations (1) to become generally familiar with and to keep the Port informed about the

progress and quality of the portion of the Work completed, (2) to endeavor to guard the Port against defects and deficiencies in the Work, and (3) to determine in general if Work is being performed in a manner indicating that the Work, when fully completed will be in accordance with the Contract Documents.

The Port's Representative will neither have control over or charge of, nor be responsible for the construction means, methods, techniques, sequences or procedures, or for the safety precautions and programs in connection with the work.

Except as otherwise provided in the Contract Documents or when direct communications have been specifically authorized, the Port and Contractor shall endeavor to communicate with each other through the Port's Authorized Representative or designee about matters arising out of or relating to the contract. Communications by and with the Architect/Engineer's consultants shall be through the Architect/Engineer. Communications by and with Subcontractors and material suppliers shall be through the Contractor. Communications by and with separate contractors shall be through the Port's Authorized Representative.

Based on the Architect/Engineer's evaluation of the Contractor's Application for Payment, or unless otherwise stipulated by the Port's Authorized Representative, the Architect/Engineer will review and certify the amounts due the Contractor and will issue Certificates for Payments in such amounts.

#### **CONTRACTOR'S MEAN AND METHODS; MITIGATION OF IMPACTS**

The Contractor shall direct and supervise the Work, using the Contractor's best skill and attention. The Contractor shall solely be responsible for and have control over construction means, methods, techniques, sequences and procedures and for coordinating all portions of the Work under this Contract, unless Contract Documents give other specific instructions concerning these matters. If the Contract Documents give specific instructions concerning construction means, methods, techniques, sequences or procedures, the Contractor shall evaluate the jobsite safety thereof and, except as stated below, shall be fully and solely responsible for the jobsite safety of such means, methods, techniques, sequences or procedures.

The contractor is responsible to protect and maintain the Work during the course of construction and to mitigate any adverse impacts to the project, including those caused by authorized changes, which may affect cost, schedule, or quality.

The Contractor is responsible for the actions of all its personnel, laborers, suppliers, and Subcontractors on the project. The Contractor shall enforce strict discipline and good order among Contractor's employees and other persons carrying out the Work. The Contractor shall not permit employment of persons who are unfit or unskilled for the tasks assigned to them.

#### **MATERIALS AND WORKMANSHIP**

The intent of the Contract Documents is to provide for the construction and completion of every detail of the Work described. All Work shall be performed in a professional manner and unless the means or methods of performing a task are specified elsewhere in the Contract Documents, Contractor shall employ methods that are generally accepted and used by the industry, in accordance with industry standards.

The Contractor is responsible to perform the Work as required by the Contract Documents. Defective work shall be corrected at the Contractor's expense.

Work done and materials furnished shall be subject to inspection and/or observation by the Port's Authorized Representative to determine if they conform to the Contract Documents. Inspection of the Work by the Port's Authorized Representative does not relieve the Contractor of responsibility for the Work in accordance with the Contract Documents.

Contractor shall furnish adequate facilities, as required, for the Port's Authorized Representative to have safe access to the Work including without limitation walkways, railings, ladders, tunnels, and platforms. Producers, suppliers, and fabricators shall also provide facilities and access to their facilities.

The Contractor shall furnish Samples of Materials for testing by the Port's Authorized Representative and include the cost of the Samples in the Contract Price.

**PERMITS**

The United States Army Corps of Engineers does not require a nationwide permit for this work. No other State or Federal permits are required.

**COMPLIANCE WITH GOVERNMENT LAWS AND REGULATIONS**

Contractor shall comply with all federal, state and local laws, codes, regulations and ordinances applicable to the Work and Contract. Failure to comply with such requirements shall constitute a breach of contract and shall be grounds for Contract termination. Without limiting the generality of the foregoing, Contractor expressly agrees to comply with the following as applicable:

- i) Title VI and VII of Civil Rights act of 1964, as amended
- ii) Section 503 and 504 of the Rehabilitation act of 1973, as amended
- iii) The Health Insurance Portability and Accountability Act of 1996
- iv) The Americans with Disabilities Act of 1990, as amended
- v) ORS Chapter 659A, as amended
- vi) All regulations and administrative rules established pursuant to the foregoing laws
- vii) All other applicable requirements of federal and state civil rights and rehabilitations statues, rules and regulations.

Port’s performance under the Contract is conditioned upon the Contractor’s compliance with the provisions of ORS 279C.505, 279C.510, 279C.515, 279C.520, and 279C.530, which are incorporated by reference herein.

Contractor shall comply with all applicable requirements of federal and state civil rights and rehabilitation statues, rules and regulations; and

- (a) Contractor shall not discriminate against Disadvantaged, Minority, Women, or Emerging Small Business enterprises, as those terms are defined in ORS 200.005, in the awarding of subcontracts (ORS 279A.110)
- (b) Contractor shall maintain, in current and valid form, all licenses and certificates required by tax, regulation, or this Contract when performing the Work.

Unless contrary to federal law, Contractor shall certify that it shall not accept a bid from Subcontractors to perform Work as described in ORS 701.005 under this contract unless such Subcontractors are registered with the Construction Contractors Board in accordance with ORS 701.035 to 701.055 at any time they submit their bids to the Contractor.

Unless contrary to federal law, Contractor shall certify that each landscape contractor, as defined in ORS 671.520(2), performing Work this Contract holds a valid landscape contractor’s license issued pursuant to ORS 671.560.

The following notice is applicable to Contractors who perform excavation Work. ATTENTION: Oregon law requires you to follow rules adopted by the Oregon Utility Notification Center. Those rules are set forth in OAR 952-001-0010 through OAR 952-001-0090. You may obtain copies of those rules by calling the center at (503)232-1987.

Failure to comply with any or all of the requirements set forth here shall be a breach of Contract and constitute grounds for Contract termination. Damages or costs resulting from such noncompliance shall be the responsibility of Contractor.

**COMPLIANCE WITH GRANT REQUIREMENTS** - (Not applicable)

**INSPECTION**

Port’s Authorized Representative shall have access to the Work at all times.

The Port’s Authorized Representative at its discretion will make inspection of Work. The Port’s Authorized Representative will have authority to reject Work that does not conform to the Contract Documents. Any Work found to be not in conformance with the Contract Documents, in the discretion of the Port’s Authorized Representative, shall be removed and replaced at the Contractor’s expense.

Contractor shall make or obtain at the appropriate time all tests, inspections and approvals of portions of the Work required by the Contract Documents or by laws, ordinances, rules, regulations, or orders of public authorities having jurisdiction. Unless otherwise provided, the Contractor shall make arrangements for such tests, inspections and approvals with an independent testing laboratory or entity acceptable to the Port, or with the appropriate public authority, and shall bear all related costs of tests, inspections, and approvals. Tests or inspections conducted pursuant to the Contract Documents shall be made promptly to avoid unreasonable delay in the Work. The Contractor shall give the Port's Authorized Representative timely notice of when and where tests and inspections are to be made so that the Port's Authorized Representative may be present for such procedures. Required certificates of testing, inspection, or approval shall, unless otherwise required by the Contract Documents, be secured by the Contractor and promptly delivered to the Port's Authorized Representative.

Work done or materials used without inspection or testing by the Port's Authorized Representative may be ordered removed at the Contractor's expense.

If directed to do so at any time before the Work is accepted, the Contractor shall uncover portions of the completed Work for inspection. After inspection, the Contractor shall restore such portions of Work to the standard required by the Contract. If the Work uncovered is unacceptable or was done with sufficient notice to Port's Authorized Representative, the uncovering and restoration will be paid for as a Change Order.

If any testing or inspection reveals failure of the portions of the Work to comply with requirements established by the Contract Documents, all costs necessary by such failure, including those of repeated procedures and compensation for the Port's Authorized Representative and Architect/Engineer's services and expenses, shall be at the Contractor's expense.

#### **SEVERABILITY**

If any provision of this Contract is declared by a court to be illegal or in conflict with any law, the validity of the remaining terms and provisions shall not be affected and the rights and obligations of the parties shall be construed and enforced as if the Contract did not contain the particular provision held to be invalid.

#### **ACCESS TO RECORDS**

Contractor shall keep, at all times on the Work site, one record copy of the complete Contract Documents, including the Plans, Specifications, Change Orders and addenda, in good order and marked currently to record filed changes and selections made during construction, and one record copy of Shop Drawings, Product Data, Samples and similar submittals, and shall at all times give the Port's Authorized Representative access thereto.

Contractor shall retain and the Port and its duly Authorized Representatives shall have access to, for a period not less than six (6) years, all Record Documents, financial and accounting records, and other books, documents, papers and records of Contractor which are pertinent to the Contract including record pertaining to Overhead and indirect costs, for the purpose of audit, examination, excerpts and transcripts. If for any reason, any part of the Contract is involved in litigation, Contractor shall retain all such records until all litigation is resolved. The Port and/or its agents shall continue to be provided full access to the records during litigation.

#### **WAIVER**

Failure of the Port to enforce any provision of this Contract shall not constitute a waiver or relinquishment by the Port of the right to such performance in the future nor the right to enforce any other provision of this Contract.

#### **SUBCONTRACTS AND ASSIGNMENT**

Contractor shall require each Subcontractor, to the extent of the Work to be performed by the Subcontractor, to be bound by the terms and conditions of these General Conditions, and to assume toward the Contractor all of the obligations and responsibilities which the Contractor assumes toward the Port thereunder, unless,

- (1) the same are clearly inapplicable to the subcontractor at issue because of legal requirements or industry practices, or



(2) specific exceptions are requested by Contractor and approved in writing by Port.

Where appropriate, Contractor shall require each subcontractor to enter in similar agreements with sub-subcontractors at any level.

At Port's request, Contractor shall submit to Port prior to their execution either Contractor's form of subcontract, or the subcontract to be executed with any particular Subcontractor. If Port disapproves such form, Contractor shall not execute the form until the matters disapproved are resolved to Port's satisfaction. Port's review, comment upon or approval of any such form shall not relieve Contractor of its obligations under this Agreement or be deemed a waiver of such obligations of Contractor.

Contractor shall not assign, sell or transfer its rights, or delegate its responsibilities under this Contract, in whole or part, without the prior written approval of the Port. No such written approval shall relieve Contractor of any obligations of this Contract, and any transferee shall be considered the agent of the Contractor and bound to perform in accordance with the Contract Documents. Contractor shall remain liable as between the original parties to the Contract as if no assignment had occurred.

### **SUCCESSORS IN INTEREST**

The provisions of this Contract shall be binding upon and shall accrue to the benefit of the parties to this Contract and their respective permitted successors and assigns.

### **PORT'S RIGHT TO DO WORK**

Port reserves the right to perform other or additional work at or near the project site with other forces than those of the Contractor. If such work takes place within or next to the project site, Contractor will coordinate with all other contractors or forces, carry out the Work in a way that will minimize interference and delay for all forces involved, place and dispose of materials being used so as not to interfere with the operations of another, and join the Work with the work of others in an acceptable manner and perform it in proper sequences to that of the others. The Port's Authorized Representative will resolve any disagreements that may arise between or among Contractor and the other contractors over the method or order of doing all work (including the Work). In case of unavoidable interference, Port's Authorized Representative will establish work priority (including the Work), which generally will be in the sequence that the contracts were awarded.

### **OTHER CONTRACTS**

In all cases and at any time, the Port has the right to execute other contracts related to or unrelated to the Work of this Contract. The Contractor of this Contract will fully cooperate with any and all other contractors without additional cost to the Port in the manner described above.

### **LITIGATION**

Any claims between Port and Contractor that arises from or related to this Contract and that is not resolved through the Port contract review board shall be brought and conducted solely and exclusively within the Circuit Court of Hood River County.

### **ALLOWANCES**

The contractor shall include in the Contract Price all allowances stated in the Contract Documents. Items covered by allowances shall be supplied for such amounts and by such persons or entities as the Port may direct.

Unless otherwise provided in the Contract Documents:

- a. When finally reconciled, allowances shall cover the cost to the Contractor of materials and equipment delivered at the site and all required taxes, less applicable trade discounts;
- b. Contractor's cost for unloading and handling at the site, labor, installation costs, Overhead, profit and other expenses contemplated for stated allowance amounts shall be included in the Contract Price but not in the allowances;

- c. Whenever costs are more than or less than allowances, the Contract Price shall be adjusted accordingly by Change Order. The amount of the Change Order shall reflect (1) the difference between actual costs and the allowances under Section (b) and (2) changes in Contractor's costs under this Section.
- d. Unless Port requests otherwise, Contractor shall provide to Port a proposed fixed price for any allowance work prior to its performance.

### **SUBMITTALS, SHOP DRAWINGS, PRODUCT DATA AND SAMPLES**

Design Build requirements apply. The Contractor shall prepare and keep current, for the Architect's/Engineer's approval (or for the approval of Port's Authorized Representative if approval authority has not been delegated to the Architect/Engineer), a schedule and list of submittals which is coordinated with the Contractor's construction schedule and allows the Architect/Engineer reasonable time to review submittals. Port reserves the right to finally approve the schedule and list of submittals. Submittals include, without limitation, Shop Drawings, Product Data, and Samples which are described below:

- a. Shop Drawings are drawings, diagrams, schedules and other data specially prepared for the Work by the Contractor or a Subcontractor (including any sub-subcontractor), manufacturer, supplier or distributor to illustrate some portion of the Work.
- b. Product Data are illustrations, standard schedules, performance charts, instructions, brochures, diagrams and other information furnished by the Contractor to illustrate materials or equipment for some portion of the Work.
- c. Samples are physical examples which illustrate materials, equipment or workmanship and establish standards by which the Work will be judged.

Shop Drawings, Product Data, Samples and similar submittals are not Contract Documents. The purpose of their submittal is to demonstrate for those portions of the Work for which submittals are required by the Contract Documents the way by which the Contractor proposes to conform to the information given and the design concept expressed in the Contract Documents the way by which the Contractor proposes to conform to the information given and the design concept expressed in the Contract Documents. Review of submittals by the Architect/Engineer is not conducted for the purpose of determining the accuracy and completeness of other details such as dimensions and quantities, or for substantiating instructions for installation or performance of equipment or systems, or for approval of safety precautions or, unless otherwise specifically stated by the Architect/Engineer, of any construction means, methods, techniques, sequences or procedures, all of which remain the responsibility of the Contractor as required by the Contract Documents. The Architect/Engineer's review of the Contractor's submittals shall not relieve the Contractor of its obligations under the Contract Documents. The Architect/Engineer's approval of a specific item shall not indicate approval of an assembly of which the item is a component. Informational submittals upon which the Architect/Engineer is not expected to take responsive action may be so identified in the Contract Documents. Submittals which are not required by the Contract Documents may be returned by the Architect/Engineer without action.

The Contractor shall review for compliance with the Contract Documents, approve and submit to the Architect/Engineer Shop Drawings, Product Data, Samples and similar submittals required by the Contract Documents with reasonable promptness and in such sequence as to cause no delay in the Work or in the activities of the Port or of separate contractors. Submittals which are not marked as reviewed for compliance with the Contract Documents and approved by the Contractor may be returned by the Architect/Engineer without action.

By approving and submitting Shop Drawings, Product Data, Samples and similar submittals, the Contractor represents that the Contractor has determined and verified materials, field measurements and field construction criteria related thereto, or will do so, and has checked and coordinated the information contained within such submittals with the requirements of the Work and of the Contract Documents.

The Contractor shall perform no portion of the Work for which the Contract Documents require submittal and review of Shop Drawings, Product Data, Samples or similar submittals until the respective submittal has been approved by the Architect/Engineer.

The Work shall be in accordance with approved submittals except that the Contractor shall not be relieved of responsibility for deviations from requirements of the Contract Documents by the Architect/Engineer's review

or approval of Shop Drawings, Product Data, Samples or similar submittals unless the Contractor has specifically informed the Architect/Engineer in writing of such deviation at the time of submittal and (1) the Architect/Engineer has given written approval to the specific deviation as a minor change in the Work, or (2) a Change Order has been executed by Port authorizing the deviation. The Contractor shall not be relieved of responsibility for errors or omissions in Shop Drawings, Product Data, Samples or similar submittals by the Architect/Engineer's review or approval thereof.

If any errors or omissions appear in the drawings, specifications or other documents the Contractor shall, immediately and before proceeding with that portion of the work affected, notify Owner or such error or omission. Should the Contractor proceed with erroneous work without giving notice, Contractor shall be responsible for errors and make required corrections without additional cost to Owner.

**SUBSTITUTIONS**

The Contractor may make Substitutions only with the consent of the Port, after evaluation by the Port's Authorized Representative and only in accordance with a Change Order. Substitutions shall be subject to the requirements of the bid documents. By making requests for Substitutions, the Contractor will provide the same warranty for the Substitution that the Contractor would for the product originally specified unless approved otherwise; certifies that the cost data presented is complete and includes all related costs under this Contract including redesign costs, and waives all claims for additional costs related to the Substitution which subsequently becomes apparent; and will coordinate the installation of the accepted Substitution, making such changes as may be required for the Work to be completed in all respects.

**USE OF PLANS AND SPECIFICATIONS**

Plans, Specifications and related Contract Documents furnished to Contractor by Port or Port's Architect/Engineer shall be used solely for the performance of the Work under this Contract. Contractor and its Subcontractors and suppliers are authorized to use and reproduce applicable portions of such documents appropriate to the execution of the Work, but shall not claim ownership or other interest in them beyond the scope of this Contract, and no such interest shall attach. Unless otherwise indicated, all common law, statutory and other reserved rights, in addition to copyrights, are retained by Port.

**FUNDS AVAILABLE AND AUTHORIZED**

Port reasonably believes at the time of entering into this Contract that sufficient funds are available and authorized for expenditure to finance the cost of this Contract within the Port's appropriation or limitation. Contractor understands and agrees that, to the extent that sufficient funds are not available and authorized for expenditure to finance the cost of this Contract, Port's Services performed after the last day of the current biennium is contingent on Port receiving from the Oregon Legislative Assembly appropriations, limitations or other expenditure authority sufficient to allow Port, in the exercise of its reasonable administrative discretion, to continue to make payments under this Contract.

**NO THIRD PARTY BENEFICIARIES**

Port and Contractor are the only parties to this Contract and are the only parties entitled to enforce its terms. Nothing in this Contract gives, is intended to give, or shall be construed to give or provide any benefit or right, whether directly, indirectly, or otherwise, to third persons unless such third persons are individually identified by name herein and expressly described as intended beneficiaries of the terms of this Contract.

**SECTION C**  
Wages & Labor

**MINIMUM WAGE RATES ON PUBLIC WORKS**

Contractor shall comply fully with the provisions of ORS 279C.800 through 279C.870. Documents establishing those conditions, as determined by the Commissioner of the Bureau of Labor and Industries (BOLI), are included as attachments to or are incorporated by reference in the Contract Documents. Contractor shall pay workers at not less than the specified minimum hourly rate of wage, and shall include that requirement in all subcontracts.

**INTENT TO PAY PREVAILING WAGE**

Approved Intent to Pay Prevailing Wage statements shall be provided to Owner prior to first pay application.

**PAYROLL CERTIFICATION; ADDITIONAL RETAINAGE; FEE REQUIREMENTS**

In accordance with ORS 279C.845, the Contractor and every Subcontractor shall submit written certified statements to the Port's Authorized Representative, on the form prescribed by the Commissioner of the Bureau of Labor and Industries, certifying the hourly rate of wage paid each worker which the Contractor or the Subcontractor has employed on the project and further certifying that no worker employed on the project has been paid less than the prevailing rate of wage or less than the minimum hourly rate of wage specified in the Contract, which certificate and statement shall be verified by the oath of the Contractor or the Subcontractor has read such statement and certificate and knows the contents thereof and that the same is true to the Contractor or Subcontractor's best knowledge and belief. The certified statements shall set out accurately and completely the payroll records for the prior week including the name and address of each worker, the worker's correct classification, rate of pay, daily and weekly number of hours worked, deductions made and actual wages paid. Certified statements for each week during which the Contractor or Subcontractor has employed a worker on the project shall be submitted once a month, by the fifth business day of the following month.

The Contractor and Subcontractors shall preserve the certified statements for a period of six (6) years from the date of completion of the Contract.

Pursuant to ORS 279C.845(7), the Port shall retain 25 percent of any amount earned by the Contractor on this public works project until the Contractor has filed the certified statements required by previous paragraphs. The Port shall pay to the Contractor the amount retained under this subsection within 14 days after the Contractor files the required certified statements, regardless of whether a Subcontractor has failed to file certified statements.

Pursuant to ORS 279C.845(8), the Contractor shall retain 25 percent of any amount earned by a first-tier Subcontractor on this public works project until the first-tier Subcontractor has filed with the Port the certified statements required by previous section. Before paying any amount retained under this subsection, the Contractor shall verify that the first-tier Subcontractor has filed the certified statement, Within 14 days after the first-tier Subcontractor files the required certified statement the Contractor shall pay the first-tier Subcontractor any amount retained under this subsection.

In accordance with statutory requirements, and administrative rules promulgated by the Commissioner of the Bureau of Labor and Industries, the fee required by ORS 279C.825(1) will be paid by Port to the Commissioner at the time Port enters into the Contract.

**PROMPT PAYMENT AND CONTRACT CONDITIONS**

Pursuant to ORS 279C.505 and as a condition to Port's performance hereunder, the Contractor shall:

- Make payment promptly, as due, to all persons supplying to Contractor labor or materials for the prosecution of the Work provided for in this Contract.
- Pay all contributions or amounts due the State Industrial Accident Fund from such Contractor or Subcontractor incurred in the performance of the Contract.
- Not permit any lien or claim to be filed or prosecuted against the Port on account of any labor or material furnished. Contractor will not assign any claims that Contractor has against Port, or assign any sums due by Port, to Subcontractors, suppliers, or manufacturers, and will not make any agreement or act in any way to give Subcontractors a claim or standing to make a claim against the Port.
- Pay to the Department of Revenue all sums withheld from employees pursuant to ORS 316.167.
- Demonstrate that an employee drug testing program is in place as follows:
  - (a) Contractor represents and warrants that Contractor has in place at the time of the execution of this Contract, and shall maintain during the term of this Contract, a Qualifying Employee Drug Testing Program for its employees that includes, at a minimum, the following:
    - (1.) A written employee drug testing policy,
    - (2.) Required drug testing for all new Subject Employees or, alternatively, required testing of all Subject Employees every 12 months on a random selection basis, and
    - (3.) Required testing of a Subject Employee when the Contractor has reasonable cause to believe the Subject Employee is under the influence of drugs.

A drug testing program that meets the above requirements will be deemed a "Qualifying Employee Drug Testing Program." For the purposes of this section, an employee is a "Subject Employee" only if that employee will be working on the project job site.

(b) Contractor shall require each Subcontractor providing labor for the project to:

- (1.) Demonstrate to the Contractor that it has a Qualifying Employee Drug Testing Program for the Subcontractor's Subject Employees, and represent and warrant to the Contractor that the Qualifying Employee Drug Testing Program is in place at the time of subcontract execution and will continue in full force and effect for the duration of the subcontract, or
- (2.) Require that the Subcontractor's Subject Employees participate in the Contractor's Qualifying Employee Drug Testing Program for the duration of the subcontract.

Pursuant to ORS 279C.515, and as a condition to Port's performance hereunder, Contractor agrees:

- If Contractor fails, neglects or refuses to make prompt payment of any claim for labor or services furnished to the Contractor of a Subcontractor by any person in connection with the project as such claim becomes due, the proper officer(s) representing the Port may pay the claim and charge the amount of the payment against funds due or to become due to Contractor under this Contract. Payment of claims in this manner shall not relieve the Contractor or the Contractor's surety from obligation with respect to any unpaid claims.
- If the Contractor or a first-tier Subcontractor fails, neglects or refuses to make payment to a person furnishing labor or materials in connection with the public contract for a public improvement within thirty (30) days after receipt of payment from Port or a contractor, the Contractor or first-tier Subcontractor shall owe the person the amount due plus interest charges commencing at the end of the 10-Day period that payment is due under ORS 279C.580(3) and ending upon final payment, unless payment is subject to a good faith dispute as defined in ORS 279C.580. The rate of interest charged to the Contractor or first-tier Subcontractor on the amount due shall equal three times the discount rate on 90-Day commercial paper in effect at the Federal Reserve Bank in the Federal Reserve district that includes Oregon on the date that is thirty (30) days after the date when payment was received from Port or from the Contractor, but the rate of interest shall not exceed thirty (30) percent. The amount of interest may not be waived.
- If the Contractor or a Subcontractor fails, neglects or refuses to make payment to a person furnishing labor or materials in connection with the Contract, the person may file a complaint with the Construction Contractors Board, unless payment is subject to a good faith dispute as defined in ORS 279C.580. Every contract related to this Contract shall contain a similar clause.

Pursuant to ORS 279C.580, Contractor shall include in each subcontract for property or services entered into by the Contractor and a first-tier Subcontractor, including a material supplier, for the purpose of performing a construction contract:

- (a) A payment clause that obligates the Contractor to pay the first-tier Subcontractor for satisfactory performance under its subcontract within ten (10) days out of such amounts as are paid to the Contractor by Port under the Contract;
- (b) An interest penalty clause that obligates the Contractor if payment is not made within thirty (30) days after receipt of payment from Port, to pay to the first-tier Subcontractor an interest penalty on amounts due in the case of each payment not made in accordance with the payment clause included in the subcontract pursuant to paragraph (a) of this subsection. Contractor or first-tier Subcontractor shall not be obligated to pay an interest penalty if the only reason that the Contractor or first-tier Subcontractor did not make payment when payment was due is that the Contractor or first-tier Subcontractor did not receive payment from Port or Contractor when payment was due. The interest penalty shall be for the period beginning on the day after the required payment date and ending on the date on which payment of the amount due is made; and shall be computed at the rate specified in ORS 279C.515(2).
- (c) A clause which requires each of Contractor's Subcontractor's to include, in each of their contracts with lower-tier Subcontractors or suppliers, provisions to the effect that the first-tier Subcontractor shall pay its lower-tier Subcontractors and suppliers in accordance with the provisions of subsections

(a) and (b), above and requiring each of their Subcontractors and suppliers to include such clauses in their subcontracts and supply contracts.

All employers, including Contractor, that employ subject workers who work under this Contract in the State of Oregon shall comply with ORS 656.017 and provide the required Workers' Compensation coverage, unless such employers are exempt under ORS 656.126. Contractor shall ensure that each of its Subcontractors complies with these requirements.

#### **PAYMENT FOR MEDICAL CARE**

Pursuant to ORS 279C.530, and as a condition to Port's performance hereunder, Contractor shall promptly, as due, make payment to any person, partnership, association or corporation furnishing medical, surgical, and hospital care or other needed care and attention, incident to sickness or injury, to the employees of such Contractor, all sums of which the Contractor agrees to pay for such service and all moneys and sums which the Contractor has collected or deducted from the wages of personnel pursuant to any law, contract or agreement for the purpose of providing or paying for such services.

#### **HOURS OF LABOR**

As a condition to Port's performance hereunder, Contractor shall comply with ORS 279C.520, as amended from time to time and incorporated herein by this reference. Contractor shall give a written schedule to employees showing the number of hours per day and days per week the employee may be required to work. Pursuant to ORS 279C.520 and as a condition to Port's performance hereunder, no person shall be employed to perform Work under this Contract for more than ten (10) hours in any day of forty (40) in any one week, except in cases of necessity, emergency or where public policy absolutely requires it. In such instances, Contractor shall pay the employee at least time and a half pay:

- (a) For all overtime in excess of eight (8) hours a day or forty (40) hours in any one week when the work week is five consecutive days, Monday through Friday, or
- (b) For all overtime in excess of ten (10) hours a day or forty hours (40) in any one week when the work week is four consecutive days Monday through Friday; and
- (c) For all Work performed on Saturday and on any legal holidays specified in ORS 279C.540.

This section will not apply to Contractor's Work under this Contract if Contractor is currently a party to a collective bargaining agreement with any labor organization.

This section shall not excuse Contractor from completion of the Work within the time required under this Contract.

### **SECTION D** Changes in Work

#### **CHANGES IN WORK**

The terms of the Contract shall not be waived, altered, modified, supplemented or amended in any manner whatsoever without prior written approval of the Port's Authorized Representative, and then only in a manner consistent with the Change Order provisions of this conditions and after any necessary approvals required by public contracting laws have been obtained. Otherwise, a formal contract amendment is required, which shall not be effective until its execution by the parties to this Contract and all approvals required by public contracting laws have been obtained.

It is mutually agreed that changes in Plans, quantities, or details of construction are inherent in the nature of construction and may be necessary or desirable during the course of construction. Within the general scope of this Contract, the Port's Authorized Representative may at any time, without notice to sureties and without impairing the Contract, require changes consistent with this section. All Change Order Work shall be executed under the conditions of the Contract Document. Such changes may include, but are not limited to:

- (a) Modifications of specifications and design.
- (b) Increases or decreases in quantities.
- (c) Increases or decreases to the amount of Work.
- (d) Addition or elimination of any Work item.
- (e) Changes in the duration of the project.

- (f) Acceleration or delay in performance of Work.
- (g) Deductive changes.

Deductive changes are those made that reduce the scope of the Work, and shall be made by mutual agreement whenever feasible. In cases of suspension or partial termination under section I, "Termination or Suspension" to follow, Port reserves the right to unilaterally impose a deductive change and to self perform such Work, for which the provisions of "Port's Right to Do Work" shall then apply.

Adjustments in compensation shall be made under the conditions following, in which costs for deductive changes shall be based upon Direct Costs adjustments together with the related percentage markup specified for profit, Overhead and other indirect costs, unless otherwise agreed to by Port.

The Port and Contractor agree that Change Order Work shall be administered and compensated according to the following:

- (a) Unit pricing may be utilized at the Port's option when unit prices or solicitation alternatives were provided that established the cost for additional Work, and a binding obligation exists under the Contract on the parties covering the terms and conditions of the additional work.
- (b) If the Port elects not to utilize the unit pricing, or if in the event that unit pricing is not available or appropriate, fixed pricing may be used for Change Work Order. In fixed pricing the basis of payments or total price shall be agreed upon in writing between the parties to the Contract, and shall be established before the Work is done whenever feasible. The mark-ups set forth following shall be utilized by the parties as a guide in establishing fixed pricing, and will not be exceeded by Port without adequate justification. Cost and price data relating to Change Orders shall be supplied by Contractor to Port upon request, but Port shall be under no obligation to make such requests.
- (c) In the event that unit pricing and fixed pricing are not utilized, then the Change Order Work shall be performed on a cost reimbursement basis for Direct Costs. Such work shall be compensated on the basis of the actual, reasonable and allowable cost of labor, equipment, and material furnished on the Work performed. In addition, the following mark-ups shall be added to the Contractor's or Subcontractor's Direct Costs as full compensation for profit, Overhead and other indirect costs for Work directly performed with the Contractor's or Subcontractor's own forces:

On labor .....15%  
 On Equipment..10%  
 On Materials.....10%

When Change Order Work is invoiced by an authorized subcontractor at any level, each ascending tier Subcontractor or Contractor will be allowed a supplemental mark-up on each piece of subcontract Work covered by such change Order as follows:

\$0.00-\$5,000.00	10%, and then
over \$5,000.00	5%

Payments made to Contractor shall be complete compensation for Overhead, profit, and all costs that were incurred by the Contractor or by other forces furnished by the Contractor, including Subcontractors, for Change Order Work. Port may establish a maximum cost for Change Order Work under this section which shall not be exceeded for reimbursement without additional written authorization from Port. Contractor shall not be required to complete such Change Order Work without additional authorization.

Any necessary adjustments of Contract Time that may be required as a result of a Change Order must be agreed upon by the parties before the start of the Change Order Work unless Port's Authorized Representative authorizes Contractor to start the work before agreement on Contract Time adjustment. Contractor shall submit any request for additional compensation and additional contract time as soon as possible but no later than thirty (30) Days after receipt of the Change Order. If not received within the time limit, Contractor's requests pertaining to that Change Order are barred. The thirty day time limit applies to claims of Subcontractors, suppliers, or manufacturers that may be affected by the Change Order.

If Port's Authorized Representative denies the Contractor's request for additional compensation or adjustment of Contract Time, the Contractor may proceed to file a claim under the Claims Review Process described hereafter in this Section D.

No request or claim by the Contractor for additional cost or an extension of Contract Time shall be allowed if made after receipt of final payment application under this Contract. Contractor agrees to submit its final payment application within ninety (90) days after Substantial Completion, unless Port grants a written extension. Contractor shall not delay final payment application for any reason.

#### **DELAYS**

Delays in construction include "Avoidable Delays", which are defined in the following section, and "Unavoidable Delays", which are defined in the one after. Found in this section are the effects of Avoidable Delays and Unavoidable Delays.

Avoidable Delays include any delays other than Unavoidable Delays, and include delays that otherwise would be considered Unavoidable Delays but that:

- (a) Could have been avoided by the exercise of care, prudence, foresight, and diligence on the part of the Contractor or its Subcontractors.
- (b) Affect only a portion of the Work and do not necessarily prevent or delay the prosecution of neither other parts of the Work nor the completion of the whole Work within the Contract Time.
- (c) Do not impact activities on the accepted critical path schedule.
- (d) Are associated with the reasonable interference of other contractors employed by the Port that do not necessarily prevent the completion of the whole Work within the Contract Time.

Unavoidable Delays include delays other than Avoidable delays that are:

- (a) Caused by any actions of the Port, Port's Authorized Representative, or any other employee or agent of the Port, or by separate contractor employed by the Port.
- (b) Caused by any site conditions which differ materially from what was represented in the Contract Documents or from conditions that would normally be expected to exist and be inherent to the construction activities defined in the Contract Documents. The Contractor shall notify the Port's Authorized Representative immediately of differing site conditions before the area has been disturbed. The Port's Authorized Representative will investigate the area and make a determination as to whether or not the conditions differ materially from either the conditions stated in the Contract Documents or those which could reasonably be expected in execution of this particular contract. If Contractor and the Port's Authorized Representative agree that a differing site condition exists, any additional compensation or additional Contract Time will be determined based on the process set forth in previous sections for Change Order Work. If the Port's Authorized Representative disagrees that a differing site condition exists and denies Contractor's request for additional compensation or Contract Time, Contractor may proceed to file a Claim under re: *Claims Review Process*. (following section)
- (c) Caused by Force Majeure acts, events or occurrences that could not have been avoided by the exercise of care, prudence, foresight, and diligence on the part of the Contractor or its Subcontractors.
- (d) Caused by adverse weather conditions. Any adverse weather conditions must be substantiated by documentary evidence that weather conditions were abnormal for the specific time period claimed, could not have been anticipated by the Contractor, and adversely impacted the project in a manner that could not be avoided by rescheduling the Work or by implementing measures to protect against the weather so that the Work could proceed. A rain, windstorm, high water, or other natural phenomenon for the specific locality of the Work, which might reasonably have been anticipated from the previous 10-year historical records of the general locality of the Work, shall not be construed as abnormal. The parties agree that rainfall greater than the following levels cannot be reasonably anticipated:
  - a. Daily rainfall equal to, or greater than, 0.50 inch during a month when the monthly rainfall exceeds the normal monthly average by twenty-five percent (25%) or more.
  - b. Daily rainfall equal to, or greater than, 0.75 inch at any time.



The Office of the Environmental Data Service of the National Oceanic and Atmospheric Administration of the U.S. Department of Commerce nearest the project site shall be considered the official agency of record for weather information.

Except as otherwise provided in ORS 279C.315, Contractor shall not be entitled to additional compensation or additional Contract Time for Avoidable Delays.

In the event of Unavoidable Delays, based on principles of equitable adjustment, Contractor may be entitled to the following:

- (a) Contractor may be entitled to additional compensation or additional Contract Time, or both, for Unavoidable Delays described earlier in section.
- (b) Contractor may be entitled to additional Contract Time for Unavoidable Delays described in previous section.

In the event of any requests for additional compensation or additional Contract Time, or both, as applicable, arising under this section for Unavoidable Delays, other than requests for additional compensation or additional Contract Time for differing site conditions for which a review process is established under previous section, Contractor shall submit a written notification of the delay to the Port's Authorized Representative within two (2) days of the occurrence of the cause of the delay. This written notification shall state the cause of the potential delay, the project components impacted by the delay, and the anticipated additional Contract Time or the additional compensation, or both, as applicable, resulting from the delay. Within seven (7) days after the cause of the delay has been mitigated, or in no case more than thirty (30) days after the initial written notification, the Contractor shall submit to the Port's Authorized Representative, a complete and detailed request for additional compensation or additional Contract Time, or both, as applicable, resulting from the delay. If the Port's Authorized Representative denies Contractor's request for additional compensation or adjustment of Contract Time, the Contractor may proceed to file a Claim under the following section, *Claims Review Process*.

If Contractor does not timely submit the notices required under this section, then unless otherwise prohibited by law, Contractor's Claim shall be barred.

### **CLAIMS REVIEW PROCESS**

All Contractor Claims shall be referred to the Port's Authorized Representative for review. Contractor's Claims, including Claims for additional compensation or additional Contract Time, shall be submitted in writing by Contractor to the Port's Authorized Representative within five (5) days after a denial of Contractor's initial request for an adjustment of Contract terms, payment of money, extension of Contract Time or other relief, provided that such initial request has been submitted in accordance with the requirements and within the time limits established in these General Conditions. Within thirty (30) days after the initial Claim, Contractor shall submit to the Port's Authorized Representative, a complete and detailed description of the Claim (the "Detailed Notice") that includes all information required by the following section. Unless the Claim is made in accordance with these time requirements, it shall be waived.

The Detailed Notice of the Claim shall be submitted in writing by Contractor and shall include a detailed, factual statement of the basis of the Claim, pertinent dates, Contract provisions which support or allow the Claim, reference to or copies of any documents which support the Claim, the dollar value of the Claim, and the Contract Time extension requested for the Claim. If the Claim involves Work to be completed by Subcontractors, the Contractor will analyze and evaluate the merits of the Subcontractor claim prior to forwarding it and that analysis and evaluation to the Port's Authorized Representative. The Port's Authorized Representative and the Port will not consider direct claims from Subcontractors, suppliers, manufacturers, or others not a party to this Contract. Contractor agrees that it will make no agreement, covenant, or assignment, nor will it commit any other act that will permit or assist any Subcontractor, supplier, manufacturer, or other to directly or indirectly make a claim against Port.

The Port's Authorized Representative will review all claims and take one or more of the following preliminary actions within ten (10) days of receipt of the Detailed Notice of a Claim: (1) request additional supporting information from the Contractor; (2) inform the Contractor and Port in writing of the time required for adequate review and response; (3) reject the Claim in whole or in part and identify the reasons for rejection;

(4) based on principles of equitable adjustment, recommend approval of all or part of the Claim; or (5) propose an alternate resolution.

The Port's Authorized Representative's decision shall be final and binding on the Contractor unless appealed by written notice to the Port within fifteen (15) days of receipt of the decision. The Contractor must present written documentation supporting the Claim within fifteen (15) days of the notice of appeal. After receiving the appeal documentation, the Port shall review the materials and render a decision within thirty (30) days after receiving the appeal documents.

The decision of the Port shall be final and binding unless the Contractor delivers to the Port its requests for mediation, which shall be a non-binding process, within fifteen (15) days of the date of the Port's decision. The mediation process will be considered to have commenced as of the date the Contractor delivers the request. Both parties acknowledge and agree that participation in mediation is a prerequisite to commencement of litigation of any disputes relating to the Contract. Both parties further agree to exercise their best efforts in good faith to resolve all disputes within sixty (60) days of the commencement of the mediation through the mediation process set forth herein.

In the event that a lawsuit must be filed within this sixty (60) day period in order to preserve a cause of action, the parties agree that notwithstanding the filing, they shall proceed diligently with the mediation to its conclusion prior to actively prosecuting the lawsuit, and shall seek from the Court in which the lawsuit is pending such stays or extensions, including the filing of an answer, as may be necessary to facilitate the mediation process. Further, in the event settlements are reached on any issues through the mediation, the parties agree to promptly submit the appropriate motions and orders documenting the settlement to the Court for its signature and filing.

The mediator shall be an individual mutually acceptable to both parties, but in the absence of agreement each party shall select a temporary mediator and the temporary mediators shall jointly select the permanent mediator. Each party shall pay its own costs for the time and effort involved in mediation. The cost of the mediator shall be split equally between the two parties. Both parties agree to exercise their best effort in good faith to resolve all disputes in mediation. Participation in mediation is a mandatory requirement of both the Port and the Contractor. The schedule, time and place for mediation will be mutually acceptable, or, failing mutual agreement, shall be as established by the mediator. The parties agree to comply with Port's mediation, if any, and shall execute all necessary documents to give effect to such confidentiality rules. In any event, the parties shall not subpoena the mediator or otherwise require the mediator to produce records, notes or work product, or to testify in any future proceedings as to information disclosed or representations made in the course of mediation, except to the extent disclosure is required by law.

Unless otherwise directed by Port's Authorized Representative, Contractor shall proceed with the Work while any Claim of Contractor is pending, including a Claim for additional compensation or additional Contract Time resulting from Change Order Work. Regardless of the review period or the final decision of the Port's Authorized Representative, the Contractor shall continue to diligently pursue the Work as identified in the Contract Documents. In no case is the Contractor justified or allowed to cease Work without a written stop work order from the Port or Port's Authorized Representative.

## **SECTION E**

### Payments

#### **BID SHEET**

The contractor shall submit, at least ten (10) days prior to submission of its first application for progress payment, a schedule of values for the contracted Work. This schedule will provide a breakdown of values for the contracted Work and will be the basis for progress payments. The breakdown will demonstrate reasonable, identifiable, and measurable components of the Work. Unless objected to by the Port's Authorized Representative, this schedule shall be used as the basis for reviewing Contractor's applications for payment. If objected to by Port's Authorized Representative, Contractor shall revise the schedule of values and resubmit the same for approval of Port's Authorized Representative.

**APPLICATIONS FOR PAYMENT**

Port shall make progress payments on the Contract monthly as Work progresses. Payments shall be based upon estimates of Work completed and the Schedule of Values. The Port's Authorized Representative shall approve all payments. A progress payment shall not be considered acceptance or approval of any Work or waiver of any defects therein. Port shall pay to Contractor interest on the progress payment, not including retainage, due the Contractor. The interest shall commence thirty (30) days after the receipt of invoice from the Contractor or fifteen (15) days after the payment is approved by the Port's Authorized Representative, whichever is the earlier date. The rate of interest shall equal three times the discount rate on 90-day commercial paper in effect at the Federal Reserve Bank in the Federal Reserve district that includes Oregon on the date that is thirty (30) days after receipt of the application for payment from the Contract or fifteen (15) days after the payment is approved by the Port, whichever is the earlier date, but the rate of interest shall not exceed thirty percent (30%). Notwithstanding the foregoing, in instances when an application for payment is filled out incorrectly, or when there is any defect or impropriety in any submitted application or when there is a good faith dispute, Port shall so notify the Contractor within fifteen (15) days stating the reason or reasons the application for payment is defective or improper or the reasons for the dispute. A defective or improper application for payment, if corrected by the Contractor within seven (7) days of being notified by the Port, shall not cause a payment to be made later than specified in this section unless interest is also paid. Accrual of interest will be postponed when payment on the principal is delayed because of disagreement between the Port and the Contractor.

Contractor shall submit to the Port's Authorized Representative, an application for each payment and, if required, receipts or other vouchers showing payments for materials and labor, including payments to Subcontractors. Contractor shall include, in its application for payment, a schedule of the percentages of the various parts of the Work completed, based on the Schedule of Values which shall aggregate to the payment application total, and shall include, on the face of each copy thereof, a certificate in substantially the following form:

"I, the undersigned, hereby certify that the above bill is true and correct, and the payment therefore, has not been received."

Signed:

\_\_\_\_\_

Generally, applications for payment will be accepted only for materials that have been installed. Under special conditions, applications for payment for stored materials will be accepted at Port's sole discretion. Such a payment, if made, will be subject to the following conditions:

- (a) The request for stored material shall be submitted at least thirty (30) days in advance of the application for payment on which it appears. Applications for payment shall be entertained for major equipment, components or expenditures only.
- (b) The Contractor shall submit applications for payment showing the quantity and cost of the material stored.
- (c) The material shall be stored in a bonded warehouse and Port's Authorized Representative shall be granted the right to access the material for the purpose of removal or inspection at any time during the Contract Period.
- (d) The Contractor shall name the Port as co-insured on the insurance policy covering the full value of the property while in the care and custody of the Contractor until it is installed. A certificate noting this coverage shall be issued to the Port.
- (e) Payments shall be made for materials only. The submitted amount of the application for payment shall be reduced by the cost of transportation and for the cost of an inspector to check the delivery at out of town storage sites. The cost of said inspection shall be borne solely by the Contractor.
- (f) Within sixty (60) days of the application for payment, the Contractor shall submit evidence of payment covering the material stored.
- (g) Payment for stored materials shall in no way indicate acceptance of the materials or waive any rights under this Contract for the rejection of the Work or materials not in conformance with the Contract Documents.
- (h) All required documentation must be submitted with the respective application for payment.

The Port reserves the right to withhold all or part of a payment, or may nullify in whole or part any payment previously made, to such extent as may be necessary in the Port's opinion to protect the Port from loss because of:

- (a) Work that is defective and not remedied, or that has been demonstrated or identified as failing to conform with the Contract Documents,
- (b) Third party claims filed or evidence reasonably indicating that such claims will likely be filed unless security acceptable to the Port is provided by the Contractor;
- (c) Failure of the Contractor to make payments properly to Subcontractors or for labor, materials or equipment (in which case Port may issue checks made payable jointly to Port and such unpaid persons under this provision, or directly to Subcontractors and suppliers at any level under previous sections.
- (d) Reasonable evidence that the Work cannot be completed for the unpaid balance of the Contract Price;
- (e) Damage to the Port or another contractor;
- (f) Reasonable evidence that the Work will not be completed within the Contract Time required by the Contract, and that the unpaid balance would not be adequate to cover actual or liquidated damages for the anticipated delay;
- (g) Failure to carry out the Work in accordance with the Contract Documents; or
- (h) Assessment of liquidated damages, when withholding is made for offset purposes.

Subject to the provisions of the Contract Documents, the amount of each progress payment shall be computed as follows:

- (a) Take that portion of the Contract Price properly allocable to completed Work as determined by multiplying the percentage completion of each portion of the Work by the share of the total Contract Price allocated to that portion of the Work in the Schedule of Values, less retainage as provided in section, *Retainage*. Pending final determination of cost to the Port of changes in the Work, amounts not in the dispute may be included even though the Contract Price has not yet been adjusted by Change Order.
- (b) Add that portion of the Contract Price properly allocable to materials and equipment delivered and suitably stored at the at the site for subsequent incorporation in the completed construction (or, if approved in advance by the Port pursuant to previous section, suitably stored off the site at a location agreed upon in writing), less retainage as provided in Section, *Retainage*.
- (c) Subtract the aggregate of previous payments made by the Port; and
- (d) Subtract any amounts for which the Port's Authorized Representative has withheld or nullified payment as provided in the Contract Documents.

Contractor's applications for payment may not include requests for payment for portions of the Work for which the Contractor does not intend to pay to a Subcontractor or material supplier.

The Contractor warrants to Port that title to all Work covered by an application for payment will pass to the Port no later than the time of payment. The Contractor further warrants that upon submittal of an application for payment all Work for which payments are received from the Port shall be free and clear of liens, claims, security interests or encumbrances in favor of the Contractor, Subcontractors, material suppliers, or other persons or entities making a claim by reason of having provided labor, materials and equipment relating to the Work.

If Contractor disputes any determination by Port's Authorized Representative with regard to any application for payment, Contractor nevertheless shall continue to prosecute expeditiously the Work. No payment made hereunder shall be or be construed to be final acceptance or approval of that portion of the Work to which such partial payment relates or shall relieve Contractor of any of its obligations hereunder.

#### **PAYROLL CERTIFICATION REQUIREMENT**

Payroll certification is required before payments are made on the Contract. Refer back to section, *Payroll Certification: Additional Retainage; Fee Requirements* for this information.

### **DUAL PAYMENT SOURCES**

Contractor shall not be compensated for Work performed under this Contract from any state agency other than the agency that is a party to this Contract.

### **RETAINAGE**

Retainage shall be withheld and released in accordance with ORS 279C.550 to 279C.580:

Port may reserve as retainage from any progress payment an amount not to exceed five percent (5%) of the payment. As Work progresses, Port may reduce the amount of the retainage and may eliminate retainage on any remaining monthly Contract payments after fifty percent (50%) of the Work under the Contract is completed if, in the Port's opinion, such Work is progressing satisfactorily. Elimination or reduction of retainage shall be allowed only upon written application by the Contractor, which application shall include written approval of Contractor's surety; except that when the Work is ninety-seven and one half percent (97.5%) completed the Port may, at its discretion and without application by the Contractor, reduce the retained amount to one hundred percent (100%) of the value of the Work remaining to be done. Upon receipt of written application by the Contractor, Port shall respond in writing within a reasonable time.

In accordance with the provisions of ORS 279C.560 and any applicable administrative rules, Contractor may request in writing:

- (a) to be paid amounts which would otherwise have been retained from progress payments where Contractor has deposited acceptable bonds and securities of equal value with Port or in a custodial account or other mutually-agreed account satisfactory to Port, with an approved bank or trust company to be held in lieu of the cash retainage for the benefit of Port;
- (b) *that retainage be deposited in an interest bearing account, established through the State Treasurer for state agencies, in a bank, savings banks, trust company or savings association for the benefit of Port, with earnings from such account accruing to the Contractor; or*
- (c) that the Port allow Contractor to deposit a surety bond for the benefit of Port, in a form acceptable to Port, in lieu of all or a portion of funds retained or to be retained. Such bonds and any proceeds therefrom shall be made priority as set forth for retainage under ORS 279C.550 to ORS 279C.625.

Where the Port has accepted the Contractor's election of option (a) or (b), Port may recover from Contractor any additional costs incurred through such election by reducing Contractor's final payment. Where the Port has agreed to Contractor's request for option (c), Contractor shall accept like bonds from Subcontractors and suppliers on the project from which Contractor has required retainages.

The retainage held by Port shall be included in and paid to the Contractor as part of the final payment of the Contract Price. The Port shall pay to Contractor interest at the rate of one and one-half percent (1.5%) per month on the final payment due Contractor, interest to commence thirty (30) days after the Work under the Contract has been completed and accepted and to run until the date Contractor shall notify Port in writing when the Contractor considers the Work complete and Port shall, within fifteen (15) days after receiving the written notice, either accept the Work or notify the contractor of Work yet to be performed on the contract. If Port does not within the time allowed notify the Contractor of Work yet to be performed to fulfill contractual obligations, the interest provided by the subsection shall commence to run thirty (30) days after the end of the fifteen (15) day period.

In accordance with the provisions of ORS 279C.560, Port shall reduce the amount of the retainage if the Contractor notifies the controller of the Port that the Contractor has deposited in an escrow account with a bank or trust company, in a manner authorized by the Port's Authorized Representative, bonds and securities of equal value of a kind approved by the Port's Authorized Representative.

Contractor agrees that if Contractor elects to reserve a retainage from any progress payment due to any Subcontractor or supplier, such retainage shall not exceed five percent (5%) of the payment, and such retainage withheld from Subcontractors and suppliers shall be subject to the same terms and conditions stated in Subsection, *Retainage* as apply to Port's retainage from any progress payment due to Contractor.

As provided in subsections under section *Payroll Certification: Additional Retainage; Fee Requirements*, additional retainage in the amount of twenty-five percent (25%) of amounts earned shall be withheld and

released in accordance with ORS 279C.845(7) when the Contractor fails to file certified statements as required by the first subsection of section, *Payroll Certification: Additional Retainage; Fee Requirements*.

### **FINAL PAYMENT**

Upon completion of all the Work under this Contract, the Contractor shall notify the Port's Authorized Representative, in writing, that Contractor has completed Contractor's part of the Contract and shall request final payment. Upon receipt of such notice the Port's Authorized Representative will inspect the Work, and if acceptable, submit to the Port a recommendation as to acceptance of the completed Work and as to the final estimate of the amount due the Contractor. If the Work is not acceptable, Port will notify Contractor within fifteen (15) days of Contractor's request for final payment. Upon approval of this final estimate by the Port and approval of this final estimate by the Port and compliance by the Contractor with provisions found in the Section titled, *Contract Close Out. 3 Affidavit/Release of liens and claims*, and other provisions as may be applicable; the Port shall pay to the Contractor all monies due under the provisions of these Contract Documents.

*Neither final payment nor any remaining retained percentage shall become due until the Contractor submits to the Port's Authorized Representative (1) a notarized affidavit/release of liens and claims in a form satisfactory to Port that states that payrolls, bills for materials and equipment, and other indebtedness connected with the Work for which the Port or the Port's property might be responsible or encumbered (less amounts withheld by Port) have been paid or otherwise satisfied, (2) a certificate evidencing that insurance required by the Contract Documents to remain in force after final payment is currently in effect and will not be cancelled or allowed to expire until at least thirty (30) Days' prior written notice has been given to the Port, (3) a written statement that the Contractor knows of no substantial reason that the insurance will not be renewable to cover the period required by the Contract Documents, (4) consent of surety, if any, to final payment and (5), if required by the Port, other data establishing payment or satisfaction of obligations, such as receipts, releases and waivers of liens, claims, security interests or encumbrances arising out of the Contract, to the extent and in such form as may be designated by the Port. If a Subcontractor refuses to furnish a release or waiver required by the Port, the Contractor may furnish a bond satisfactory to the Port to indemnify the Port against such lien. If such lien remains unsatisfied after payments are made, the Contractor shall refund to the Port all money that the Port may be compelled to pay in discharging such lien, including all costs and reasonable attorneys' fees.*

Acceptance of final payment by the Contractor, a Subcontractor or material supplier shall constitute a waiver of claims by that payee except those previously made in writing and identified by that payee as unsettled at the time of final application for payment.

## **SECTION F**

### **Job Site Conditions**

### **USE OF PREMISES**

Contractor shall confine equipment, storage of materials and operation of Work to the limits indicated by Contract Documents, law, ordinances, permits or directions of the Port's Authorized Representative. Contractor shall follow the Port's Authorized Representative's instructions regarding use of premises, if any.

### **PROTECTION OF WORKERS, PROPERTY, AND THE PUBLIC**

Contractor shall maintain continuous and adequate protection of all of the Work from damage, and shall protect the Port's Authorized Representative, Port's workers and property from injury or loss arising in connection with this Contract. Contractor shall remedy acceptably to the Port, any damage, injury, or loss, except such as may be directly due to errors in the Contract Documents or caused by authorized representatives or personnel of the Port. Contractor shall adequately protect adjacent property as provided by law and the Contract Documents.

Contractor shall take all necessary precautions for the safety of all personnel on the job site, and shall comply with the Contract Documents and all applicable provisions of federal, state and municipal safety laws and building codes to prevent accidents or injury to persons on, about or adjacent to the premises where the Work is being performed. Contractor shall erect and properly maintain at all times, as required by the conditions and progress of workers and the public against any hazards created by construction. Contractor shall designate a responsible employee or associate on the Work site, whose duty shall be the prevention of

accidents. The name and position of the person designated shall be reported to the Port's Authorized Representative. The Port's Authorized Representative has no responsibility for Work site safety. Work site safety is the responsibility of the Contractor.

Contractor shall not enter upon private property without first obtaining permission from the property Port or its duly Authorized Representative. Contractor shall be responsible for the preservation of all public and private property along and adjacent to the Work contemplated under the Contract and shall use every precaution necessary to prevent damage thereto. In the event the Contractor damages any property, the Contractor shall at once notify the property owner and Port and make, or arrange to make, full restitution. Contractor shall report, immediately in writing, to the Port's Authorized Representative, all pertinent facts relating to such property damage and the ultimate disposition of the claim for damage.

Contractor is responsible for protection of adjacent work areas including impacts brought about by activities, equipment, labor, utilities, and materials on the site.

Contractor shall at all times direct its activities in such a manner as to minimize adverse effects on the environment. Handling of all materials will be conducted so no release will occur that may pollute or become hazardous.

In an emergency affecting the safety of life or of the Work or of adjoining property, the Contractor, without special instruction or authorization from the Port's Authorized Representative, shall act reasonably to prevent threatened loss or injury, and shall so act, without appear, if instructed by the Port's Authorized Representative. Any compensation claimed by the Contractor on account of emergency work shall be determined in accordance with the Section titled *Changes in the Work*.

Contractor shall, at its sole expense, provide all traffic control signage, barriers, and flaggers at no additional cost to Owner.

### **CUTTING AND PATCHING**

Contractor shall be responsible for coordinating all cutting, fitting, or patching of the Work to make its several parts come together properly and fit to receive or be received by work of other Contractors or Subcontractors shown upon, or reasonably implied by, the Contract Documents.

Contractor shall be responsible for restoring all cut, fitted, or patched surfaces to an original condition; provided, however, that if a different condition is specified in the Contract Documents, then Contractor shall be responsible for restoring such surfaces to the condition specified in the Contract Documents.

### **CLEANING UP**

From time to time as may be ordered by the Port the Contractor shall, at its own expense, clean up and remove all refuse and unused materials of any kind resulting from the Work. If Contractor fails to do so within twenty-four (24) hours after notification by the Port, the work may be done by others and the cost charged to the Contractor and deducted from payment due to the Contractor.

### **DISPOSAL OF SURPLUS MATERIALS**

No waste site has been provided by Owner for the disposal of excess materials and debris. Debris shall be taken by Contractor to a disposal site approved by Owner. Contractor shall keep site clean, safe and free of debris. Contractor shall dispose of waste materials in an Owner-approved location.

### **ENVIRONMENTAL CONTAMINATION**

Contractor will be held responsible for and shall indemnify, defend (with counsel of Port's choice) and hold harmless Port from and against any costs, expenses, damages, claims, and causes action, (including attorney fees), or any of them, resulting from all spills, releases, discharges, leaks and disposal of environmental pollution, including storage, transportation and handling during the performance of the Contract which occur as a result of, or are contributed by, the negligence or actions of Contractor or its personnel, agents, or Subcontractors or any failure to perform in accordance with the Contract Documents (except to the extent otherwise void under ORS 30.140). Nothing in this section shall limit Contractor's responsibility for obtaining insurance coverage required under section titled *Insurance* of these General Conditions, and Contractor shall take no action that would void or impair such coverages.

Contractor agrees to promptly dispose of such spills, releases, discharge or leaks to the satisfaction of proper regulatory agencies in a manner that complies with applicable federal, state, and local laws and regulations. Cleanup shall be at no cost to the Port and be performed by properly qualified personnel.

Contractor shall obtain the Port's written consent prior to bringing onto the Work site any (i) environmental pollutants or (ii) hazardous substances or materials, as the same or reasonably similar terms are used in many applicable federal, state, or local statutes, rules and ordinances. Notwithstanding such written consent from the Port, the Contractor, at all times, shall:

- (a) properly handle, use and dispose of all environmental pollutants and hazardous substances or materials brought onto the Work site, in accordance with all applicable federal, state or local statutes, rules or ordinances;
  - i. Contractor must have in date spill response kit on the dock or work vessel and assessable at all times.
- (b) be responsible for any and all spills, releases, discharges, or leaks of (or from) environmental pollutants or hazardous substances or materials which Contractor has brought onto the Work site; and
- (c) promptly clean up, without cost to the Port, such spills, releases, discharges, or leaks to the Port's satisfaction and in compliance with all applicable federal, state, or local statutes, rules or ordinances.

Contractor shall report all reportable quantity releases to applicable federal, state, and local regulatory and emergency response agencies. Reportable quantities are found in 40 CFR Part 302, Table 302.4 for hazardous substances and in OAR Chapter 340 Division 108 for all products addressed therein. Upon discovery, regardless of quantity, Contractor must telephonically report all releases to the Port. A written follow-up report shall be submitted to the Port within forty-eight (48) hours of the telephonic report. Such written report shall contain, as a minimum:

- (a) Description of items released (identity, quantity, manifest no., and all other documentation required by law.
- (b) Whether amount of items released is EPA/DEQ reportable, and, if so, when it was reported.
- (c) Exact time and location of release, including a description of the area involved.
- (d) Containment procedures initiated.
- (e) Summary of communications about the release Contractor has had with members of the press or State officials other than Port.
- (f) Description of cleanup procedures employed or to be employed at the site, including disposal location of spill residue.
- (g) Personnel injuries, if any, resulting from, or aggravated by, the release.

#### **ENVIRONMENTAL CLEAN-UP**

Unless disposition of environmental pollution is specifically a part of this Contract, or was caused by the Contractor (reference section titled *Environmental Contamination*), Contractor shall immediately notify Port of any hazardous substance(s) which Contractor discovers or encounters during performance of the Work required by this Contract. "Hazardous Substance(s)" means any hazardous, toxic and radioactive materials and those substances defined as "hazardous substances," "hazardous materials," "hazardous wastes," "toxic substances," or other similar designations in any federal, state, or local law, regulation, or ordinance, including without limitation asbestos, polychlorinated biphenyl (PCB), or petroleum, and any substances, materials or wastes regulated in 40 CFR, Part 261 and defined as hazardous in 40 CFR S 261.3. In addition to notifying Port of any hazardous substance(s) discovered or encountered, Contractor shall immediately cease working in any particular area of the project where a hazardous substance(s) has been discovered or encountered if continued to work in such area would present a risk or danger to the health or well being of Contractor's or Subcontractor's work force.

Upon being notified by Contractor of the presence of hazardous substance(s) on the project site, Port shall arrange for the proper disposition of such hazardous substance(s).



**FORCE MAJEURE**

A party to this Contract shall not be held responsible for delay or default due to Force Majeure acts, events or occurrences unless they could have been avoided by the exercise of reasonable care, prudence, foresight, and diligence by that party. The Port may terminate this Contract upon written notice after determining that delay or default caused by Force Majeure acts, events or occurrences will reasonably prevent successful performance of the Contract.

**SECTION G**

Indemnity, Bonding, and Insurance

**RESPONSIBILITY FOR DAMAGES/INDEMNITY**

Contractor shall be responsible for all damages to property, injury to persons, and loss, expense, inconvenience, and delay that may be caused by, or result from the carrying out of Work to be done under this Contract, or from any act, omission or neglect of the Contractor, its Subcontractors, personnel, or agents.

To the fullest extent permitted by law, Contractor shall indemnify and hold harmless the PORT, Port's Authorized Agent, its properties, officers, employees, and Architect/Engineer Consultants from and against all liabilities, damages, losses, claims, expenses (including reasonable attorney fees), demands and actions of any nature whatsoever which arise out of, result from or are related to (a) any damage, injury, loss, expense, inconvenience or delay described here, (b) any accident or occurrence which happens or is alleged to have happened in or about the project site or any place where the Work is being performed, or in the vicinity of either at any time prior to the time the Work is fully completed, (c) any failure of the Contractor to observe or perform any duty or obligation under the Contract Documents which is to be observed or performed by the Contractor, or any breach of agreement, representation or warranty of the Contractor contained in the Contract Document or any subcontract, (d) the negligent acts or omissions of the Contractor, a subcontractor or anyone directly or indirectly employed by them or any one of them or anyone for whose acts they may be liable, regardless of whether or not such claim, damage, loss or expense is caused in part by a party indemnified hereunder (except to the extent otherwise void under ORS 30.140) and (e) any lien filed upon the project or bond claim in connection with the Work. Such obligation shall not be construed to negate, abridge, or reduce other rights or obligations of indemnity which would otherwise exist as to a party or persons described in this section.

**PERFORMANCE AND PAYMENT SECURITY; PUBLIC WORKS BOND**

When the contract price is \$100,000 or more (\$50,000 or more in the case of Contracts for highways, bridges and other transportation projects) the Contractor shall furnish and maintain in effect at all times during the Contract Period, a performance bond in a sum equal to the Contract Price, and a separate payment bond also in a sum equal to the Contract Price. The bonds may be required if the Contract Price is less than the above thresholds, if required by the Contract Documents.

Before starting Work, the Contractor shall file with the Construction Contractors Board, and maintain in full force and effect, the separate public works bond required by Oregon laws 2005, chapter 360, and OAR 839-025-0015, unless otherwise exempt from those provisions. The Contractor shall also include in every subcontract a provision requiring the Subcontractor to have a public works bond filed with the Contractors Construction Board before starting Work, unless otherwise exempt, and shall verify that the Subcontractor has filed a public works bond before permitting the Subcontractor to start Work.

## **INSURANCE**

**Worker's Compensation:** All employers, including Contractor, that employ subject workers who work under this contract in the State of Oregon shall comply with ORS 656.017 and provide the required Workers Compensation coverage, unless such employers are exempt under ORS 656.126. This shall include Employer's Liability Insurance with coverage limits of not less than \$100,000 for each accident. Contractors who perform the Work without the assistance or labor of any employee need not obtain such coverage if the Contractor certifies so in writing. Contractor shall ensure that each of its subcontractors complies with these requirements. The Contractor shall require proof of such Workers' Compensation by receiving and keeping on file a certificate of insurance from each Subcontractor or anyone else directly employed by either the Contractor or Subcontractors.

**Builder's Risk:** During the term of this Contract, for new construction the Contractor shall maintain in force, at its own expense, Builder's Risk Insurance on an all risk form, including earthquake and flood, for an amount equal to the full amount of the Contract. Such insurance shall be maintained until the Owner has occupied the facility.

**Commercial General Liability Insurance:** Contractor shall obtain, at Contractor's expense, and keep in effect during the term of this Contract, Commercial General Liability Insurance covering bodily injury and property damage in a form and with coverages that are satisfactory to the Port. This insurance shall include personal injury liability, products and completed operations, and contractual liability coverage for the indemnity provided under this Contract (to the extent contractual liability coverage for the indemnity is available in the marketplace), and shall be issued on an occurrence basis. Combined single limit per occurrence shall not be less than \$1,000,000 for each job site or location. Each aggregate limit shall not be less than \$1,000,000.

**Automobile Liability:** Contractor shall obtain, at Contractor's expense, and keep in effect during the term of this Contract, Automobile Liability Insurance owned, non-owned and/or hired vehicles, as applicable. The coverage may be written in combination with the Commercial General Liability Insurance. Combined single limit per occurrence shall not be less than \$1,000,000, or the equivalent.

**Tail Coverage:** If any of the required liability insurance is on a "claims made" basis, "tail" coverage will be required at the completion of the Contract for a duration of 24 months. Contractor will be responsible for furnishing certification of "tail" coverage as described or continuous "claims made" liability for twenty-four (24) months following Final Completion. Continuous "claims made" coverage will be acceptable in lieu of "tail" coverage, provided its retroactive date is on or before the effective date of this Contract. This will be a condition of final acceptance.

**Additional Insured:** The liability Insurance coverage, except for the Professional Liability if included, required for this Contract shall include the Port, officers, and employees, as Additional Insureds but only with respect to the Contractor's activities to be performed under this Contract.

There shall be no cancellation, material change, potential exhaustion coverages without thirty (30) Days' written notice from the Contractor or its insurer(s) to the Port.

As evidence of coverage, Contractor shall furnish the a certificate of insurance to Port prior to Issuance of a Notice to Proceed. The certificate will specify all of the parties who are Additional Insureds or Loss Payees. Insurance coverages required under this Contract shall be obtained from insurance companies or entities acceptable to the Port that are allowed to provide such insurance under Oregon law. The certificate will also specify that there shall be no cancellation, material change, potential exhaustion of aggregate limits or intent to not renew insurance coverages without thirty (30) Days' written notice from the insurer(s) to Port. The Contractor shall be financially responsible for all deductibles, self-insured retentions and/or self-insurance included hereunder. Any deductible, self-insured retention and/or self insurance in excess of \$50,000 shall be approved by the Port in writing prior to issuance of a Notice to Proceed and is subject to Port's approval.

Insurance coverages required under this Contract shall be obtained from insurance companies or entities acceptable to the Port that are allowed to provide such insurance under Oregon law.

**Jones Act: The contractor must be aware of the requirements of this act and have the necessary maritime insurance in place.**

## **SECTION H**

### Schedule of Work

#### **CONTRACT PERIOD**

Time is of the essence on this contract. The Contractor shall at all times carry on the Work diligently, without delay and punctually fulfill all requirements herein. Contractor shall commence work within ten (10) days of Notice to Proceed, unless otherwise directed.

Unless specifically extended by Change Order, all Work shall be complete by the date contained in the Contract Documents.

The Port will not waive any rights under the Contract by permitting the Contractor to continue or complete the Work or any part of it after the date described above.

#### **SCHEDULE**

Contractor shall provide, by or before the pre-construction conference, a detailed schedule for review and acceptance by the Port. The submitted schedule must illustrate Work by significant project components, significant labor trades and long lead times. Schedules lacking adequate detail, or unreasonably detailed, will be rejected. Included within the schedule are the following: Notice to Proceed, Substantial Completion, and Final Completion. Schedules will be updated monthly and submitted with the monthly pay application. Acceptance of the schedule by the Port does not constitute agreement by the Port, as to the Contractor's sequencing, means, methods or allocated Contract Time. In no case shall the Contractor make a request for additional compensation for delays if the Work is completed within the Contract Time but after the Contractor's scheduled completion.

#### **WORKING DAYS**

Contractor shall complete all physical Contract Work within the number of "working days" stated in the Contract Provisions or as extended by Owner. Every day will be counted as a "working day" unless it is a nonworking day or an Owner-determined unworkable day. A nonworking day is defined as a Saturday, a Sunday, a day on which the Contract specifically suspends Work, or one of these Owner holidays: New Year's Day, Presidents' Day, Memorial Day, Independence Day, Labor Day, Veterans' Day, Thanksgiving Day, and Christmas Day.

An unworkable day is defined as a half or whole day Owner declares to be unworkable because of weather or conditions caused by the weather that prevents satisfactory and timely performance of the Work shown on the critical path of the Contractor's approved progress schedule. Other conditions beyond the control of the Contractor may qualify for an extension of time.

Each working day shall be charged to the Contract as it occurs, until the Contract Work is physically complete. If Substantial Completion has been granted and all the authorized working days have been used, charging of working days will cease. Each week the Owner will provide the Contractor a statement that shows the number of working days: (1) charged to the Contract the week before; (2) specified for the Physical Completion of the Contract; and (3) remaining for the Physical Completion of the Contract. The statement will also show the nonworking days and any half or whole day the Owner declares as unworkable. Within 10-calendar days after the date of each statement, the Contractor shall file a written protest of any alleged discrepancies in it. To be considered by the Owner, the protest shall be in sufficient detail to enable the Owner to ascertain the basis and amount of time disputed. By not filing such detailed protest in that period, the Contractor shall be deemed as having accepted the statement as correct.

Owner will give the Contractor written notice of the Physical Completion Date for all Work the Contract requires. That date shall constitute the Physical Completion Date of the Contract, but shall not imply Owner acceptance of the Work or the Contract.

Owner will give Contractor written notice of the Completion Date of the Contract after all the Contractor's obligations under the Contract have been performed by the Contractor. The following events must occur before the Completion Date can be established:

1. The physical Work on the project must be complete; and
2. The Contractor must furnish all documentation required by the Contract and required by law, to allow Owner to process final acceptance of the Contract. The following documents must be received by Owner prior to establishing a Completion Date:
  - a. Certified Payrolls
  - b. Material Acceptance Certification Documents
  - c. Final Contract Voucher Certification

## **SECTION I**

### Correction of Work

#### **BEFORE FINAL PAYMENT**

The Contractor warrants to the Port that materials and equipment furnished under this Contract will be of good quality and new unless otherwise required or permitted by the Contract Documents, that the work will be free from defects, and that the Work will conform to the requirements of the Contract Documents. Work failing to conform to these requirements shall be deemed defective. Contractor shall promptly remove from the premises and replace all defective materials and equipment as determined by the Port's Authorized Representative, whether incorporated in the Work or not. Removal and replacement shall be without loss or expense to the Port, and Contractor shall bear the cost of repairing all Work destroyed or damaged by such removal or replacement. Contractor shall be allowed a period of no longer than sixty (60) days for completion of defective (punch list) work, unless otherwise agreed. At the end of that period, or earlier if requested by the Contractor, the Port shall arrange for inspection of the Work by the Architect/Engineer. Should the work not be complete, and all corrections made, the costs for all subsequent re-inspections shall be borne by the Contractor. If Contractor fails to complete the punch list work within the above time period, without affecting Contractor's obligations the Port may perform such work and Contractor shall reimburse the Port all costs of the same within thirty (30) days after demand.

#### **WARRANTY WORK**

Neither the final certificate of payment nor any provision of the Contract Documents shall relieve the Contractor from responsibility for defective work and, unless a longer period is specified, Contractor shall correct all defaults that appear in the work within a period of one year from the date of issuance of the written notice of substantial completion by the Port except for latent defects which will be remedied by the Contractor at any time they become apparent.

The Port shall give the Contractor notice of defects with reasonable promptness. Contractor shall perform such warranty work within a reasonable time after Port's demand. If Contractor fails to complete the warranty work within such period as Port determines reasonable, or at any time in the event of warranty work consisting of emergency repairs, without affecting Contractors obligations, Port may perform such work and Contractor shall reimburse Port all costs of the same within thirty (30) days after demand.

This provision does not negate guarantees or warranties for periods longer than one year including without limitations such guarantees or warranties required by other sections of the Contract Documents for specific installations, materials, processes, equipment or fixtures.

In addition to Contractor's warranty, manufacturer's warranties shall pass to the Port and shall not take effect until affected work has been accepted in writing by the Port's Authorized Representative.

The one-year (1) period for correction of Work shall be extended with respect to portions of Work performed after substantial completion by the period of time between substantial completion and the performance of the work, and shall be extended by corrective Work performed by the Contractor pursuant to this section, as to work corrected.

If the Port prefers to accept Work which is not in accordance with the requirements of the Contract Documents, the Port may do so instead of requiring its removal and correction, in which case the Contract

Price will be reduced as appropriate and equitable. Such adjustment shall be effected whether or not final payment has been made.

**Section J**  
Suspension or Termination of the Work

**PORT'S RIGHT TO SUSPEND WORK**

The Port and the Port's Authorized Representative has the authority to suspend portions or all of the Work due to the following causes:

- (a) Failure of the Contractor to correct unsafe conditions;
- (b) Failure of the Contractor to carry out any provision of the Contract;
- (c) Failure of the Contractor to carry out orders;
- (d) Conditions, in the opinion of the Port's Authorized Representative, which are unsuitable for performing the work;
- (e) Time required to investigate differing site conditions;
- (f) Any reason considered to be in the public interest.

The Port shall notify the Contractor and the Contractor's Surety in writing of the effective date and time of the suspension and shall notify Contractor and its Surety in writing to resume work.

**CONTRACTOR'S RESPONSIBILITIES**

During the period of suspension, Contractor is responsible to continue maintenance at the project just as if the work were in progress.

**COMPENSATION FOR SUSPENSION**

Depending on the reason for suspension of the Work, the Contractor or the Port may be due compensation from the other party. If the suspension was required due to acts or omissions of the Contractor, the Port may assess the Contractor actual costs of the suspension. If the suspension was caused by acts or omissions of the Port, the Contractor shall be due compensation which shall be defined under "Changes in Work". If the suspension was required through no fault of the Contractor or the Port, neither party owes the other for the impact.

**PORT'S RIGHT TO TERMINATE CONTRACT**

The Port without prejudice to any other right or remedy, and after giving Contractor seven (7) Days written notice and an opportunity to cure, terminate the Contract in whole or part under the following conditions:

- (a) If Contractor should voluntarily or involuntarily, seek protection under the US Bankruptcy Code and Contractor as debtor-in-possession or the Trustee for the estate fails to assume the Contract within a reasonable time;
- (b) If Contractor should make a general assignment for the benefit of Contractor's creditors;
- (c) If a receiver should be appointed on account of Contractor's insolvency;
- (d) If Contractor should repeatedly refuse or fail to supply an adequate number of skilled workers or proper materials to carry on the Work as required by the Contract Documents, or otherwise fail to perform the Work in a timely manner;
- (e) If Contractor should repeatedly fail to make prompt payment to Subcontractors or for material or labor, or should disregard laws, ordinances or the instructions of the Port or Authorized Representative;
- (f) If Contractor is otherwise in material breach of any part of the Contract.

At any time the above occurs, the Port may exercise all rights and remedies available to Port at law or equity, and in addition, Port may take possession of the premises and all of the materials and appliances and finish the Work by whatever method it may deem expedient. In such case, the Contractor shall not be entitled to receive further payment until the work is completed. If the Port's cost of finishing the Work exceeds the unpaid balance of the Contract Price, Contractor shall pay the difference to the Port.

#### **TERMINATION FOR CONVENIENCE**

Port may terminate the Contract in whole or in part whenever Port determines that termination of the Contract is in the best interest of the public.

The Port will provide the Contractor with seven (7) Days' prior written notice of a termination for public convenience. After such notice, the Contractor shall provide the Port with immediate and peaceful possession of the premises and materials located on and off premises for which the Contractor received progress payment. Compensation for Work terminated by the Port under this provision will be paid according to the terms of "Payment of Work." In no circumstances shall Contractor be entitled to lost profits for Work not performed due to termination.

#### **ACTION UPON TERMINATION**

Upon receiving a notice of termination, and except as otherwise directed by the Port, Contractor shall immediately cease placing further subcontracts or orders for materials, services, or facilities. In addition, Contractor shall terminate all subcontracts or orders to the extent they relate to the Work terminated and, with the prior written approval of the Port, settle all outstanding liabilities and termination settlement proposals arising from the termination of subcontracts and orders.

As directed by the Port, Contractor shall upon termination transfer title and deliver to the Port all record documents, information, and other property that, if Contract had been completed, would have been required to be furnished to the Port.

### **SECTION K**

#### **Contract Close Out**

#### **RECORD DOCUMENTS**

As a condition of final payment, Contractor shall comply with the following: Contractor shall provide to the Port's Authorized Representative, Record Documents ("Record Drawings;" "As Built") of the entire project. Record Documents shall depict the project as constructed and shall reflect every change, modification, and deletion made during the construction. Record Documents are part of the Work and shall be provided prior to the issuance of final payment. Record Documents include all modifications to the Contract Documents unless otherwise directed. Record Documents shall be provided in an electronic format along with paper copies in 24"x36" dimension.

#### **OPERATION AND MAINTENANCE MANUALS**

The O & M Manuals shall contain a complete set of all submittals, all product data as required by the specifications, training information, phone list of consultants, manufactures, installer and suppliers, manufacturer's printed data, record and shop drawings, schematic diagrams of systems, appropriate equipment indices, warranties and bonds. The Port's Authorized Representative shall review and return one O & M Manual for any modifications or additions required. Prior to submission of its final pay request, Contractor shall deliver three (3) complete and approved sets of O & M Manuals to the Port's Authorized Representative.

#### **AFFIDAVIT/RELEASE OF LIENS AND CLAIMS**

As a condition of final payment, the Contractor shall submit to the Port's Authorized Representative a notarized affidavit/release of liens and claims form, in a form satisfactory to the Port, which states that all subcontractors and suppliers have been paid in full, all disputes with property owners and the Port have been resolved, all obligations on the project have been satisfied, all monetary claims and indebtedness have been paid, and that to the best of the Contractor's knowledge, there are no claims of any kind outstanding against the project. The Contractor shall indemnify, defend (with counsel of Port's choice) and hold

harmless the Port from all claims for labor and materials furnished under this Contract.

**COMPLETION NOTICES**

Contractor shall provide the Port notice of both Substantial and Final Completion. The certificate of Substantial Completion shall state the date of Substantial Completion, the responsibilities of the Port and the Contractor for security, maintenance, heat, utilities, damage to Work and insurance, and the time within which the Contractor shall finish all items on the punch list accompanying the Certificate. Both completion notices must be signed by the Contractor and the Port to be valid. The Port shall provide the final signature on the notices. The notices shall take effect on the date signed by the Port.

**TRAINING**

As part of the Work, and prior to submission of the request for final payment, the Contractor shall schedule with the Port's Authorized Representative, training sessions for all equipment and systems, as required in the individual specifications sections. The O & M Manuals shall be used as a basis for training.

**EXTRA MATERIALS**

As part of the Work, Contractor shall provide spare parts, extra maintenance materials, and other materials or products in the quantities specified in the specifications, prior to final payment.

**ENVIRONMENTAL CLEANUP**

As part of the Final Completion notice, or as a separate written notice submitted with or before the Final Completion, the Contractor shall notify the Port that all environmental pollution clean-up which was performed as part of this Contract has been disposed of in accordance with all applicable rules, regulations, laws, and statues of all agencies having jurisdiction over such environmental pollution. The notice shall reaffirm the indemnification given under Section E.

**CERTIFICATE OF OCCUPANCY**

The Contractor shall not be granted Final Completion or receive final payment if the Port has not received an unconditioned certificate of occupancy from the appropriate state and/or local building officials, unless failure to obtain an unconditional certificate of occupancy is due to the fault or neglect of the Port.

**OTHER CONTRACTOR RESPONSIBILITIES**

The Contractor shall be responsible for returning to the Port all items issued during construction such as keys and all other pertinent items. The Contractor shall be responsible for notifying the appropriate utility companies to transfer utility charges from Contractor to the Port.

**SURVIVAL**

All warranty and indemnification provisions of this Contract, and all of Contractor's other obligations under this contract that are not fully performed by the time of Final Completion or termination, shall survive Final Completion or any termination of the Contract.

**SECTION L**

Legal Relations & Responsibilities

**LAWS TO BE OBSERVED**

In compliance with ORS 279C.525, there are federal, state, and local agencies of which the Port has knowledge that have enacted ordinances or regulations relating to environmental pollution and the preservation of natural resources that may affect the performance of the Contract.

**PART 9**  
**TECHNICAL SPECIFICATIONS**



## SPECIAL PROVISIONS – UNDERWATER CONCRETE REPAIR

### DESCRIPTION

**1.01 Description of Work.** Perform underwater concrete patching repairs at Piers 6 and 8 of the Hood River-White Salmon Interstate Bridge in accordance with the plans and these special provisions.

### MATERIAL

**1.02 Material Standards.** Materials, equipment, and devices provided shall be manufactured for the specific purposes used and shall have demonstrated success on projects Contractor has performed. Materials shall meet the following requirements:

- Steel plate forms shall be at least 1/4" thick and conform to ASTM A36, or better.
- Anchor rods shall conform to ASTM F1554 Grade 36, ASTM A307, or better, and be hot-dip galvanized.
- Nuts and washers shall be hot-dip galvanized and compatible with the anchor rod used.
- Resin bonded anchors shall utilize epoxy resin conforming to ASTM C881.
- Provide underwater non-shrink grout with a minimum compressive strength of 5000 psi that conforms to ASTM C1107 and CRD 661-06. Use coarse sand in lieu of pea gravel for thick sections.

### CONSTRUCTION REQUIREMENTS

**1.03 Contractor Experience.** Contractors shall have a minimum of 5 years of successful experience performing similar underwater concrete repairs. Provide at least 5 reference projects which involved similar work. Include the name of client, reference contact information, and a description of work performed.

**1.04 Field Verification.** Repair areas in plans are approximate in size, orientation, and location. Field verify the extent of the repair areas shown that are two inches in depth and greater. Document the field verified repair areas with video recording and sketch drawings with height, width, and depth dimensions for void pockets with depth of two inches and greater and the dimensions of additional area needed for sealing the forms.

Notify the Engineer immediately if areas other than those shown on plans are identified that meet the potential repair criteria. Do no work on those areas until approved by the Engineer.

**1.05 Submittals.** Provide the following submittals:

- Notice to Mariners – At least four weeks prior to commencing on-site work provide schedule and operation information to Port for U.S. Coast Guard issued Notice to Mariners.
- Safety Plan – At least two weeks prior to commencing on-site work provide a Safety Plan with details of the safety measures and protocols for all aspects of the work. Include details for safe operation of vessels and equipment, above water work area safety practices for specific work to be performed, below water work area safety practices for specific work to be performed, accident and injury protocols, company safety officer and on-site safety supervisor.
- Repair Procedures Workplan – At least two weeks prior to commencing on-site work provide a Repair Procedures Workplan with details of methods, equipment, and procedures for

fabricating and installing forms, sealing of forms, and grouting process for approval by the Engineer. If changes to details shown in the plans are proposed, provide the reasons for proposed change and demonstrate prior successful use.

- Pollution Control and Water Quality Plan – At least two weeks prior to commencing on-site work provide a Pollution Control and Water Quality Plan with details of environmental protection measures. Include preventive and containment measures on vessels to prevent oils and fuels from entering the water, provide clean-up methods and materials should spills occur. Provide preventive and containment measures to keep fresh grout from being discharged into the water.
- Field verification documentation per Subsection 1.04 submitted to Engineer for approval prior to initiating repairs.

**1.06 Surface Preparation.** Pressure wash or manually brush surface of void pocket area to remove marine growth or loose material. If excessive material removal occurs, reduce pressure or use manual methods to minimize additional removal.

**1.07 Forms.** Provide steel forms anchored to the concrete that are watertight. Provide ports in forms for injection of grout and expulsion of water to verify displacement.

**1.08 Grouting.** Fill void pockets by pressure grouting using displacement method. Provide a means of capturing grout discharges needed to verify full displacement of water within void form. Dispose of captured grout discharge in an acceptable manner for waste products.

**1.09 Inspection.** Provide video documentation of grouting procedure for demonstration of voids being fully displaced and grout discharge captured. Provide video files in .mp4 format as grouting work progresses, preferably within 24 hours but no more than 48 hours after void is grouted. At the Engineer’s discretion, forms shall be removed after adequate curing to verify grouted repair condition. At the Contractor’s discretion forms may be left in place after work is completed.

**1.10 Documentation.** Provide documentation of the void areas, form dimensions, anchorage and port locations, and volumes of grout applied. Sketch diagrams provided under Subsection 1.04 are acceptable with updates for end results, as needed, and completed volumes.

## MEASUREMENT

**1.11 Method of Measurement.** Measurement for the work will be on the lump sum basis. The estimated quantities of repair areas are:

Location	Average Height (in.)	Average Width (in.)	Average Depth (in.)	Form Plate Area (sq. ft.) *	Grout Volume (cu. ft.) **
Pier 6 – South Face	10	18	4	4.58	0.51
	7	10	8	2.90	0.37

Location	Average Height (in.)	Average Width (in.)	Average Depth (in.)	Form Plate Area (sq. ft.) *	Grout Volume (cu. ft.) **
	15	72	3	15.75	2.29
	16	30	7	8.17	2.14
	48	96	10	45.00	28.17
	72	96	2	63.00	10.20
Pier 6 – North Face	30.0	24.0	6	10.50	2.78
	7.0	36.0	6	6.33	1.00
	5.0	72.0	4	9.92	1.03
	30.0	30.0	3	12.25	1.90
	15.0	144.0	3	29.25	5.81
<b>Pier 6 Totals</b>	-	-	-	<b>208</b>	<b>55</b>
Pier 8 – South Face	8.00	13.00	18.00	6.94	1.20
	10.00	264.00	4.00	42.17	7.20
	8.00	264.00	4.00	38.33	5.82
	120	180	4.00	176.00	56.60
	24.00	204.00	7.00	54.00	21.52
Pier 8 – North Face	120.00	180.00	4.00	176.00	56.60
	12.00	60.00	4.00	12.00	1.96
	3.00	36.00	8.00	5.00	0.58
<b>Pier 8 Totals</b>	-	-	-	<b>507</b>	<b>152</b>

\* Plate areas assume 6" added to all sides of void.

\*\* Grout volume includes ½" of relief and 2" added to all sides of void.

#### PAYMENT

**1.12 Basis of Payment.** The lump sum bid shall include the cost of furnishing all labor, materials, and equipment necessary to complete the work for "Underwater Concrete Repair".

Progress payments will be authorized as a percentage of the lump sum price based on the following schedule:

- Twenty percent (20%) of the lump sum price will be paid upon mobilization to the site.
- Ten percent (10%) of the lump sum price will be paid upon completion of field verification documentation.
- Twenty percent (20%) of the lump sum price will be paid upon completion of Pier 6 repairs.
- Forty percent (40%) of the lump sum price will be paid upon completion of Pier 8 repairs.
- Ten percent (10%) of the lump sum price will be paid upon final completion of all work, demobilization, and submittal of documentation.

If the field verified grout volumes, accepted by the Engineer, exceeds the estimated quantities by more than ten percent, then a negotiated adjustment to the lump sum price will be entertained.

Additional void pockets identified during field verification and agreed to by the Engineer will be negotiated for additional compensation before being approved and added to the work.

**PART 10**  
**CONSTRUCTION PLANS**

# PORT OF HOOD RIVER COMMISSION HOOD RIVER, OREGON

PLANS FOR PROPOSED PROJECT

## HOOD RIVER INTERSTATE BRIDGE UNDERWATER PIER REPAIR HOOD RIVER - WHITE SALMON HWY.

HOOD RIVER, OR. AND KLICKITAT, WA. COUNTIES

MARCH 2023

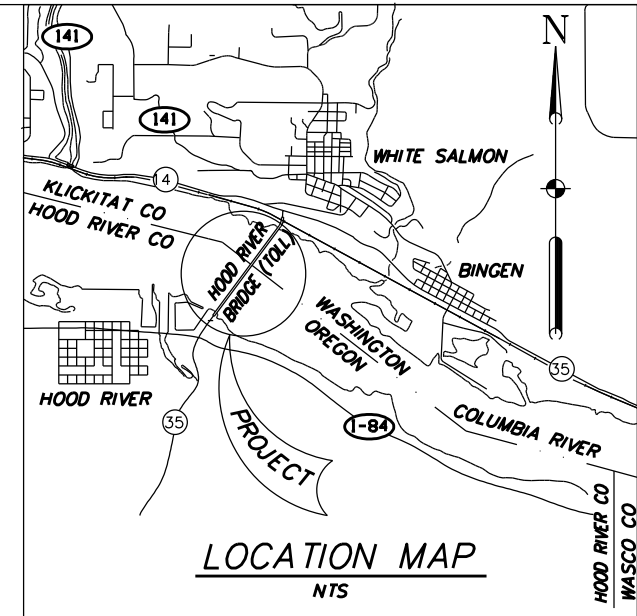

**General Notes:**

1. The dimensions shown on the plans are based on drawings of the existing structure and inspection reports, and are assumed to be approximate. Field verify all dimensions and field fit conditions.
2. Structural steel plates shall be ASTM A36 minimum.
3. Anchor rods shall be hot-dip galvanized ASTM A307 or ASTM F1554, Grade 36 minimum.
4. Non-shrink grout shall have a minimum compressive strength of 5000 psi and conform to ASTM C1107 and CRD 661-06.
5. Conform to AWS D1.1 or D3.6 for all welds.
6. Do not scale dimensions from the plans.

PROJECT PLANS	
SHEET NO.	DESCRIPTION
1	TITLE SHEET & GENERAL NOTES
2	GENERAL ELEVATION
3	PIER 6 NORTH & SOUTH FACE ELEVATIONS
4	PIER 8 NORTH & SOUTH FACE ELEVATIONS
5	PIER 6 & 8 REPAIR DETAILS
ODOT STANDARD DRAWINGS	
DWG. NO.	DESCRIPTION
-----	-----

△	DATE	REVISION	BY	DRAFTER: <i>E. Gahan</i>	   	STRUCTURE NO. 06645	HOOD RIVER INTERSTATE BRIDGE UNDERWATER PIER REPAIRS HOOD RIVER-WHITE SALMON HIGHWAY HOOD RIVER, OR & KLICKITAT, WA COUNTIES	SHEET 1 OF 5	
				DESIGNER: <i>M. Libby</i>		DATE March 2023		TITLE SHEET & GENERAL NOTES	DRAWING NO.
				CHECKER: <i>S. Timilsina</i>		CALC. BOOK			110036
ACCOMPANIED BY DWGS.				REVIEWER: <i>M. Mitchell</i>		RENEWS: 12-31-2024			

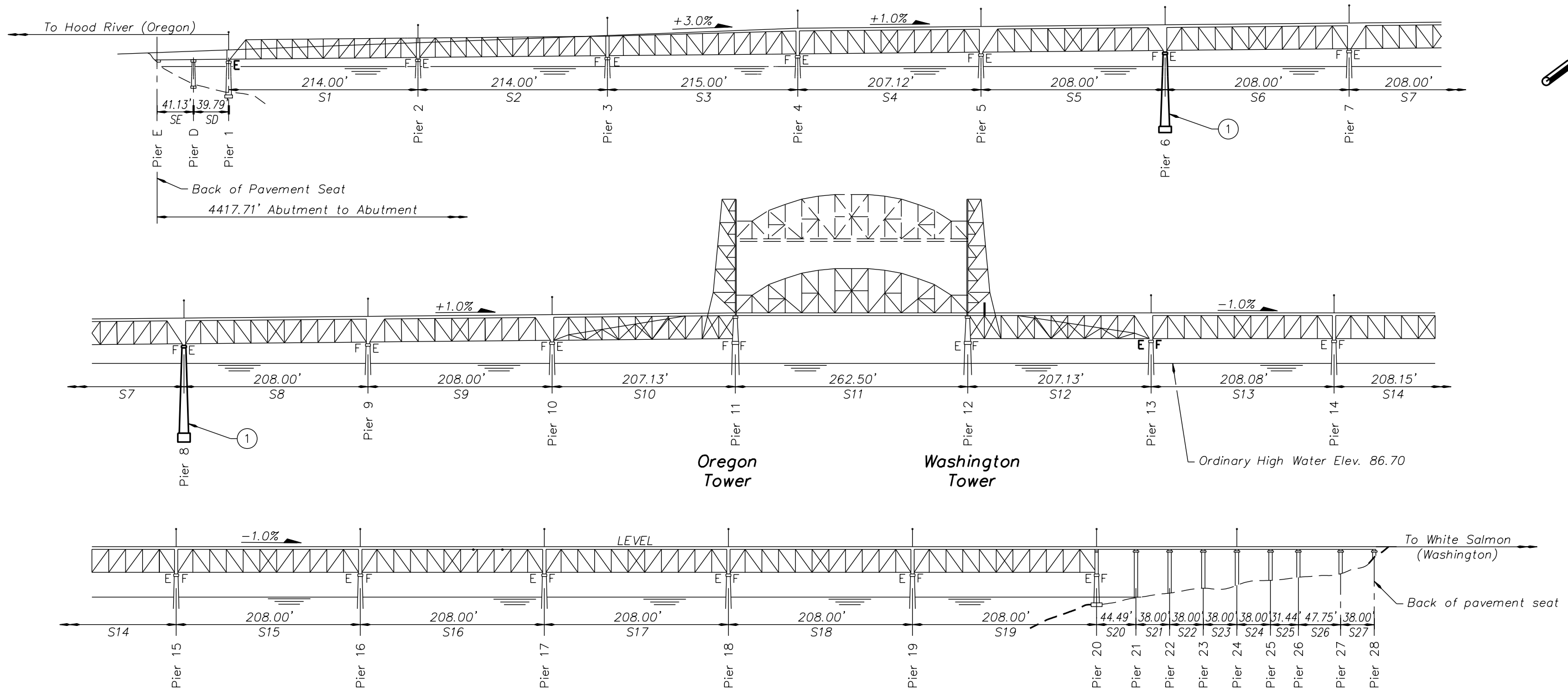
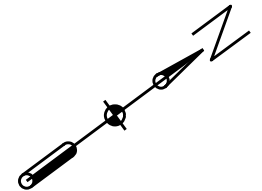

**BRIDGE ELEVATION**

Scale: NTS  
 (East side of bridge shown, looking west)  
 (West side similar except as noted)

Work Items:

- ① Underwater concrete repair

	DATE	REVISION	BY	DRAFTER: <i>E. Gahan</i>					STRUCTURE NO. 06645	<b>HOOD RIVER INTERSTATE BRIDGE                  UNDERWATER PIER REPAIRS                  HOOD RIVER-WHITE SALMON HIGHWAY                  HOOD RIVER, OR &amp; KLICKITAT, WA COUNTIES</b>	SHEET 2 OF 5
				DESIGNER: <i>M Libby</i>					DATE March 2023		DRAWING NO.
				CHECKER: <i>S. Timilsina</i>					CALC. BOOK		
	ACCOMPANIED BY DWGS.								REVIEWER: <i>M. Mitchell</i>		RENEWS: 12-31-2024

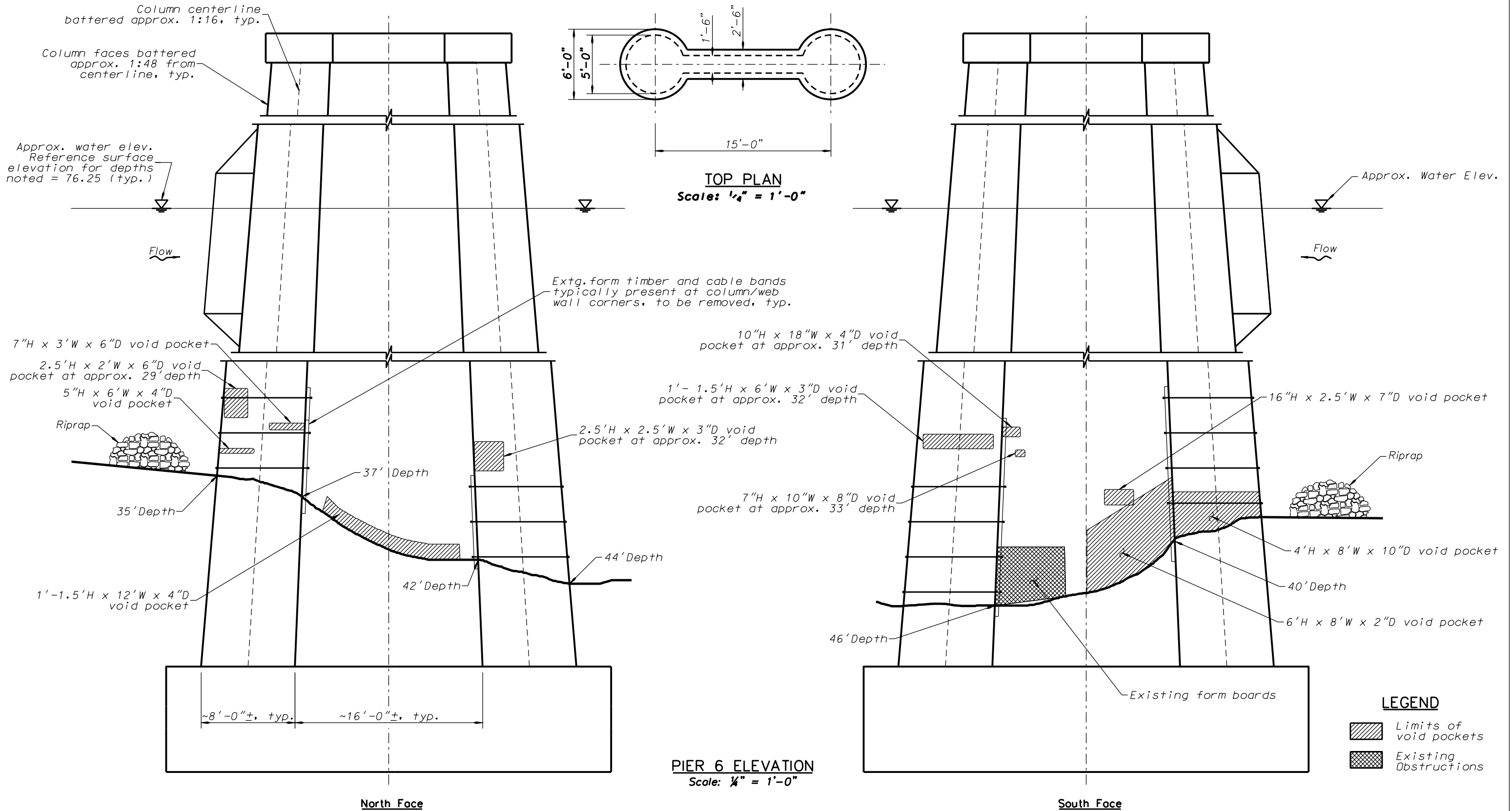

North Face

South Face

	DATE	REVISION	BY	DRAFTER: E. Gahan DESIGNER: M. Libby CHECKER: S. Timilsina REVIEWER: M. Mitchell					STRUCTURE NO. 06645	HOOD RIVER INTERSTATE BRIDGE UNDERWATER PIER REPAIRS HOOD RIVER-WHITE SALMON HIGHWAY HOOD RIVER, OR & KLICKITAT, WA COUNTIES	SHEET 3 OF 5
									DATE March 2023 CALC. BOOK		PIER 6 NORTH & SOUTH FACE ELEVATIONS

ACCOMPANIED BY DWGS.

RENEWS: 12-31-2024



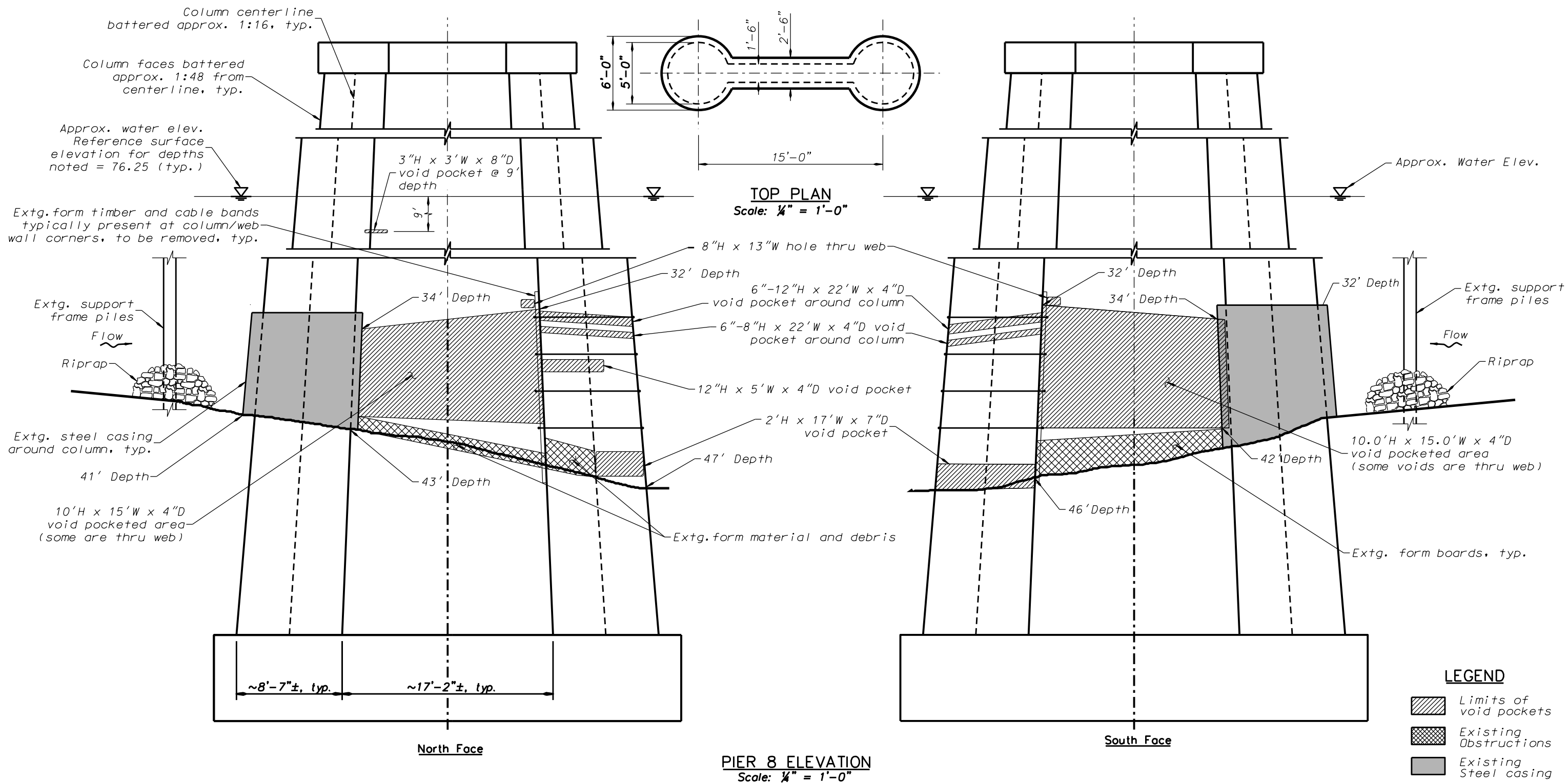

Δ	DATE	REVISION	BY

ACCOMPANIED BY DWGS.

DRAFTER: E. Gahan  
 DESIGNER: M. Libby  
 CHECKER: S. Timilsina  
 REVIEWER: M. Mitchell

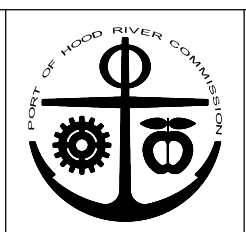
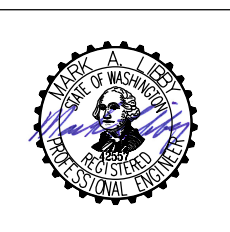
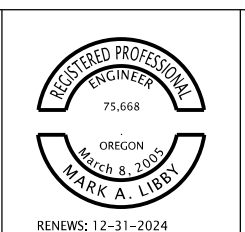

STRUCTURE NO.  
06645  
 DATE  
March 2023  
 CALC. BOOK

**HOOD RIVER INTERSTATE BRIDGE  
 UNDERWATER PIER REPAIRS  
 HOOD RIVER-WHITE SALMON HIGHWAY  
 HOOD RIVER, OR & KLICKITAT, WA COUNTIES**

**PIER 8 NORTH & SOUTH FACE ELEVATIONS**

SHEET  
4  
OF  
5  
 DRAWING NO.  
110039

Notes:

1. Depths shown on pier elevations are in reference to the river gage elevation on the day of the inspection, Oct. 14, 2019. Depths are approximate.
  2. Ground conditions at piers are approximate and based on the conditions on the day of the inspection. Minor hand movement of material may be needed for void pockets at groundline.
  3. Form timbers and cables are present at various locations. Locations shown on pier elevations are approximate and not all inclusive. These materials are to be removed and properly disposed of if in the way of repairs, or at the option of Contractor if not in the way.
  4. The void areas shown are not inclusive of all deterioration present. The intent of repairs is to address sufficiently large void areas with depths of 2" or more.
  5. Void pocket areas shown are approximate and shapes are irregular. Pocket depths shown are an approximate average for that area.
  6. Repair details assume that steel forms can be sealed within a 6" oversize of the void area shown. Shapes are irregular and adjacent areas may have roughness up to 1/2" depth. Contractor to verify actual size of steel form plates needed to meet the objectives of repairs noted herein.
  7. Grout patches may have a relief up to 1/2" from the adjacent surface.
  8. Closely spaced void pockets may be combined for form application at Contractors discretion.
  9. Details shown represent anticipated repair methods. Contractor shall submit repair details for alternative methods per the special provisions for approval by the Engineer.
  10. Anchor rods shall be 5/8" or 3/4" diameter as determined by Contractor for the spacing and pressure applied. For resin bonded anchors, provide minimum embedment into sound concrete according to manufacturers recommendations.
  11. Contractor to determine size and thickness of steel form plates, but shall be 1/4" minimum thickness.
- Construction Sequence:**
1. Pressure wash or manually brush surface of void pocket area to remove marine growth or loose material. If excessive material removal occurs, reduce pressure or use manual methods to minimize additional removal.
  2. Verify void pocket area and size of form needed.
  3. Prepare form plates and compressible seals.
  4. Install anchors. Allow adequate cure time for resin bonded anchors before installing form plates.
  5. Install forms and test seal prior to applying grout.
  6. Install grout using displacement method, ensuring that displaced water and grout are contained in a closed system until discharged at surface.
  7. Verify grout placement by volume and positive discharge at ports, closing ports as placement progresses.

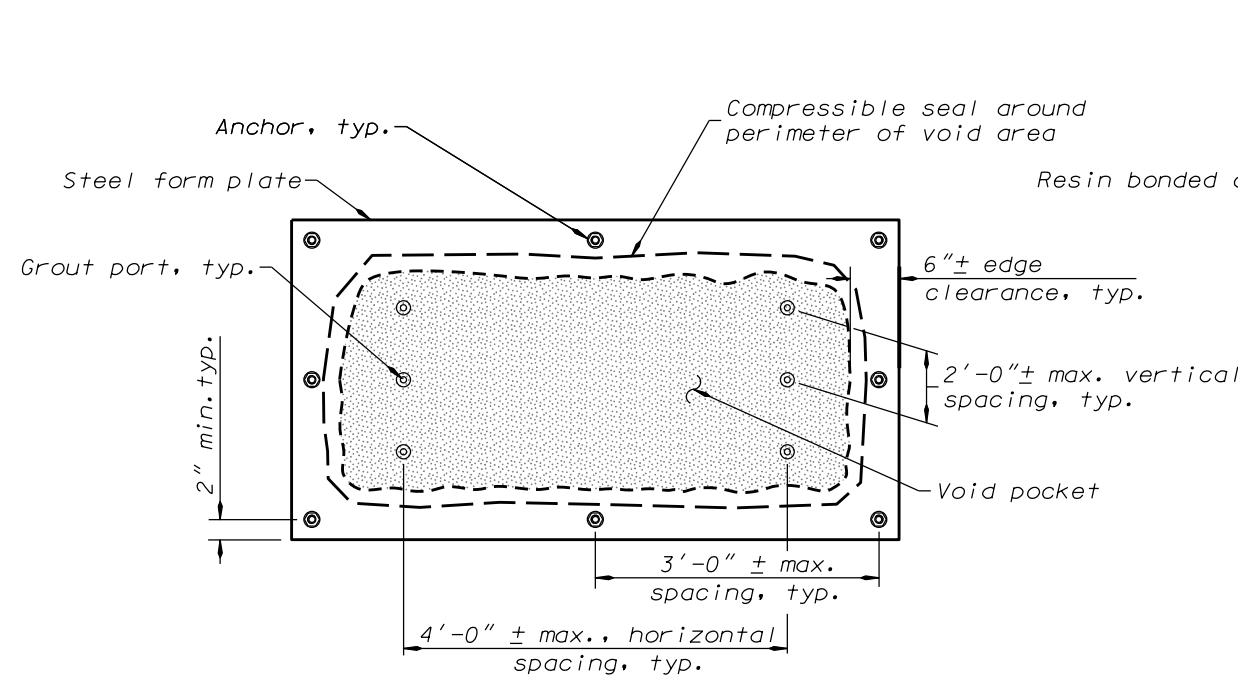

**REPAIR ELEVATION DETAIL**  
Scale: NTS

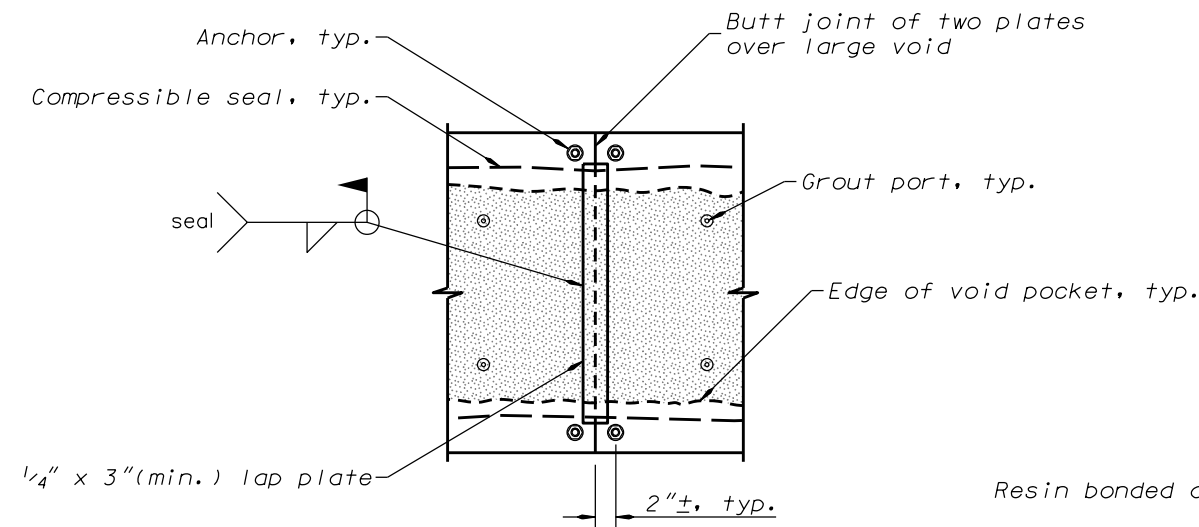

**ADJOINING PLATE DETAIL**  
Scale: NTS

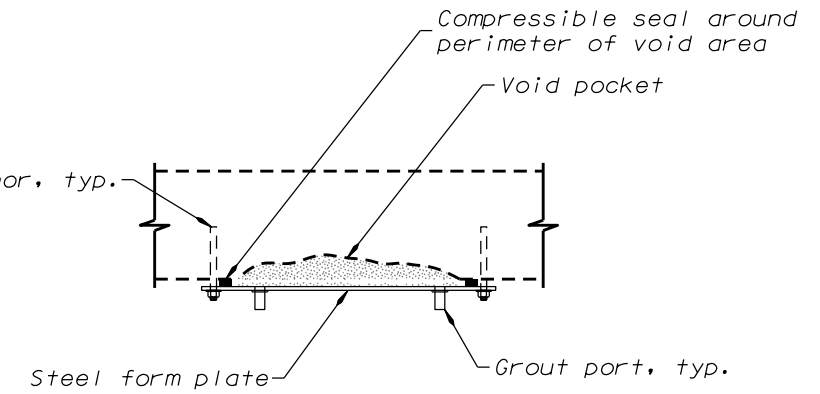

**WEB WALL SECTION - 1 SIDED REPAIR**  
Scale: NTS

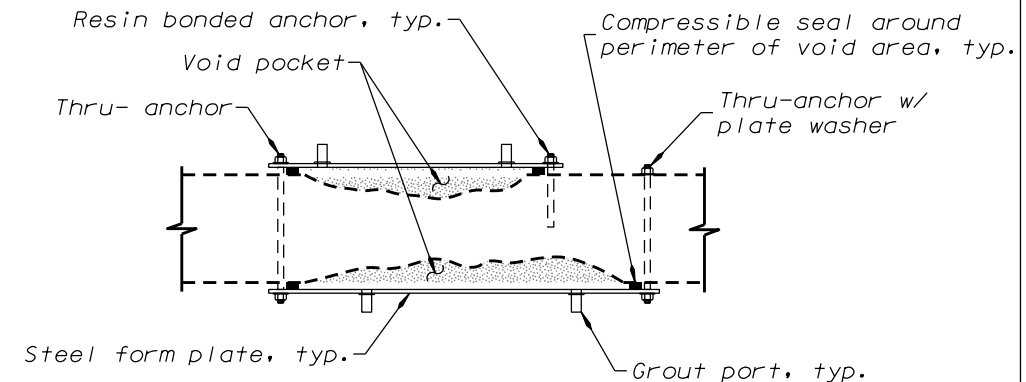

**WEB WALL SECTION - 2 SIDED REPAIR**  
Scale: NTS

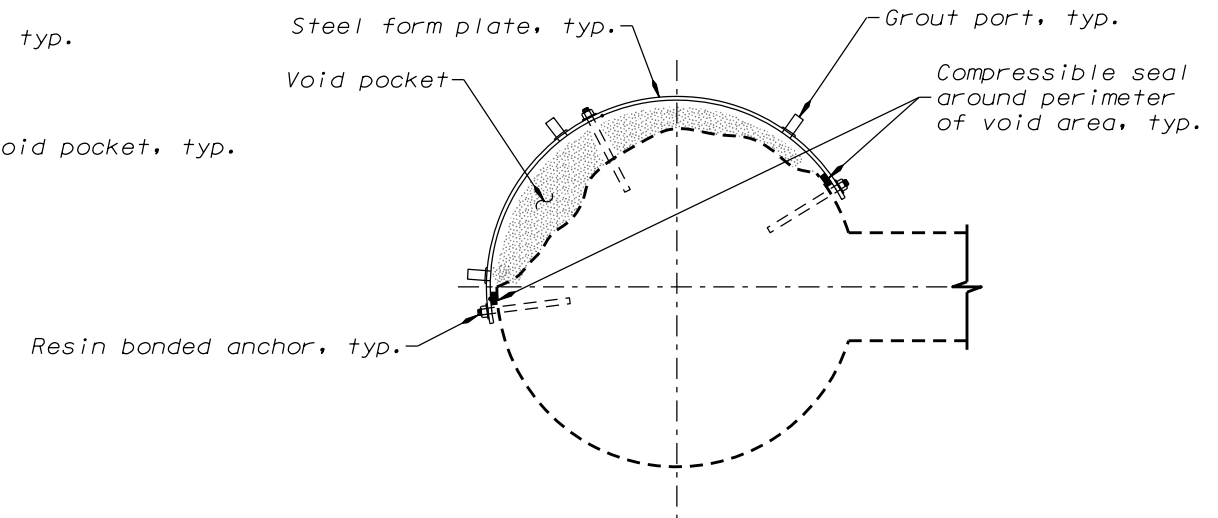

**COLUMN SECTION REPAIR**  
Scale: NTS

	DATE	REVISION	BY	DRAFTER: E. Gahan						STRUCTURE NO. 06645	<b>HOOD RIVER INTERSTATE BRIDGE UNDERWATER PIER REPAIRS HOOD RIVER-WHITE SALMON HIGHWAY HOOD RIVER, OR &amp; KLICKITAT, WA COUNTIES</b>	SHEET 5 OF 5
				DESIGNER: M. Libby						DATE March 2023		DRAWING NO.
				CHECKER: S. Timilsina						CALC. BOOK		110040
	ACCOMPANIED BY DWGS.									REVIEWER: M. Mitchell		

**PART 11**

**PORT OF HOOD RIVER  
PUBLIC IMPROVEMENT CONTRACT  
(Sample)**

**PORT OF HOOD RIVER  
PUBLIC IMPROVEMENT CONTRACT**

This Contract entered into between the PORT OF HOOD RIVER, an Oregon municipal corporation, ("PORT") and \_\_\_\_\_ ("CONTRACTOR"), shall become effective when this Contract has been signed by both parties and the Port has issued to CONTRACTOR a Notice to Proceed with the Work.

**WITNESSETH:**

**WHEREAS**, CONTRACTOR, having examined the Work site and become familiar and satisfied with conditions, has submitted an acceptable bid for Underwater Pier Repair for the Hood River Bridge at Hood River, Oregon 97031 ("Work"); and,

**WHEREAS**, the parties hereto desire that this Contract be undertaken and completed on the terms and conditions as hereafter set forth;

**THEREFORE, IT IS AGREED AS FOLLOWS:**

**Terms of Performance**

CONTRACTOR agrees to perform the described Work and provide all machinery, tools, apparatus, materials, equipment, labor and other means of construction necessary to complete the Work at the designated location in accordance with all terms specified in the Contract Documents, which by this reference are incorporated herein, including the following:

- A) Invitation to Bid
- B) Bidding Instructions
- C) First-Tier Subcontractor Disclosure Form
- D) Bid Form/Bid Schedule
- E) Bid Bond
- F) Performance Bond
- G) Payment Bond
- H) Certificate of Insurance
- I) General Conditions of Public Works Contracts
- J) Notice of Intent to Award
- K) Notice to Proceed
- L) Payment of Prevailing Wages Rates
- M) Drawings prepared for/or issued by PORT
- N) Specifications prepared for/or issued by PORT
- O) All affidavits and certifications submitted by CONTRACTOR as part of CONTRACTOR's Bid Documents, which affidavits and certifications CONTRACTOR agrees will remain effective throughout the term of this Contract.

**Contract Price:**

Subject to the provisions of all Contract Documents and in consideration of the faithful performance of the terms and conditions thereof by the CONTRACTOR, PORT agrees to pay CONTRACTOR \_\_\_\_\_, in the manner and at the times provided in the Contract Documents. The Contract price is for completing the Work. No alternates are included.

**Contract Dates:**

Project Start Date: 10 calendar days from issuance of Notice to Proceed.  
Substantial Completion: June 30, 2023  
Final Completion: July 15, 2023

**Liquidated damages**

If the CONTRACTOR fails to complete the Work within the time specified or within any extension of time agreed to by both parties in writing, CONTRACTOR shall pay liquidated damages of \$250.00, for each day of delay beyond the completion day identified above. (If no dollar amount is specified this paragraph shall not apply to this Contract.)

**Representatives**

Unless otherwise specified in the Contract Documents, the Port designates John Mann, as its Authorized Representative in the administration of this Contract. The above-named individual shall be the initial point of contact for matters relating to performance, payment, authorization, and to carry out the responsibilities of the Port. Contractor has named \_\_\_\_\_ its Authorized Representative to act on its behalf.

**Integration**

The Contract Documents and this Contract constitute the entire agreement between the parties. No waiver, consent, modification or change of terms of this Contract shall bind either party unless in writing and signed by both parties. Such waiver, consent, modification or change, if made, shall be effective only in the specific instance and for the specific purpose given. There are no other understandings, agreements, or representations, oral or written, not specified herein regarding this Contract. Contractor, by the signature below of its authorized representative, hereby acknowledges that it has read this Contract, understands it, and agrees to be bound by its terms and conditions.

IN WITNESS WHEREOF the parties have executed this Contract on \_\_\_\_\_, 20\_\_.

\_\_\_\_\_  
**CONTRACTOR**

\_\_\_\_\_  
**PORT OF HOOD RIVER**

By \_\_\_\_\_

By \_\_\_\_\_

Its \_\_\_\_\_

Its \_\_\_\_\_

**PORT OF HOOD RIVER**  
**Resolution No. 2022-23-14**

**A RESOLUTION ESTABLISHING A TOLLING REVENUES USE POLICY**

**WHEREAS**, the Port of Hood River (the "Port") has owned and operated the Hood River White Salmon Interstate Bridge (the "Bridge") since 1950 and, in addition to Bridge operations and maintenance, has utilized a portion of toll revenue for economic development in the Port District through the development of the Hood River waterfront and other industrial and commercial properties; AND

**WHEREAS**, a portion of toll revenues have also been utilized to benefit the Hood River Airport, Hood River Marina, waterfront parks and recreation, and other Port property; AND

**WHEREAS**, the Port's bridge engineers' current Capital Maintenance Plan anticipates \$90 million in costs for capital repair and maintenance in the next 15 years; AND

**WHEREAS**, the Port Commission wishes to establish the goal that the Port will eventually generate adequate operating income to cover non-bridge activities and not rely on tolls as a source for those non-bridge activities; AND

**WHEREAS**, the Washington and Oregon legislature are currently in session and efforts are underway to secure significant funding for the replacement effort; AND

**WHEREAS**, the Port has been advised that some portion of bridge replacement funding is likely to be contingent upon the Port using tolls exclusively for bridge operations, repair, and replacement by no later than June 30, 2026; AND

**WHEREAS**, the Port Commission supports the efforts of our government affairs consultants, the Bi-State Working Group, and staff to obtain funding for the replacement bridge effort; NOW THEREFORE THE PORT OF HOOD RIVER BOARD OF COMMISSIONERS RESOLVES AS FOLLOWS:

**Section 1.** It is the official policy of the Port of Hood River to accomplish the goal of operating all non-bridge related activities without toll revenue by no later than June 30, 2026.

**Section 2.** Resolution 2022-23-11 is hereby repealed.

Adopted by the Board of Commissioners of the Port of Hood River this 18th day of April 2023.

**SIGNED**

  
Ben Sheppard, President

**ATTEST**

  
Michael Fox, Secretary